

Technical Memorandum

Development Application

BCC DS
RECEIVED
29/04/2026
APPLICATION REF
A006992477



Date	29 April 2026	Project Number	P0046052
Client	New Day Church	Prepared By	Meghana Dinesh Bhagavathalu
Project	577 Boston Rd, Chandler	Reviewed By	Andrew Tierney RPEQ#34680

Introduction

Background

An Other Change Application is to be submitted to Brisbane City Council (Council) on behalf of New Day Church for an expansion of the existing church facilities provided at the existing New Day Church located at 577 Boston Road, Chandler.

Urbis has been engaged by New Day Church to provide traffic engineering support in relation to this application, including preparation of this Traffic Impact Assessment (TIA). This TIA has been prepared to review the traffic and transport aspects of the development proposal, including an assessment of traffic impacts on the surrounding road network.

It is noted that the 577 Boston Road site maintains an existing approval for a place of worship (A006523102).

Subject Site

The subject site is approximately 11,820 square metres (sqm) and is located at 577 Boston Road, Chandler, formally described as Lot 396 on RP33387. Based on Council's City Plan, the site is zoned as 'Environmental Management'. The site currently maintains the New Day Church, with an approved capacity of 65 people. The location of the subject site is provided in Figure 1.

Figure 1 – Site Location



Source: Nearmap.com (Aerial dated 24 August 2025)

Proposed Development

The development proposal includes a staged expansion of the existing development at 577 Boston Road, Chandler, including the following:

- Delivery of additional buildings and on-site facilities.

- Increased person capacity to 350 persons maximum (regular service of approx. 150 persons).
- On-site carpark to support an increased Church capacity.

A summary of the proposed changes is provided in Table 1.

Table 1 – Development Proposal

Description	Church Auditorium / Seating area	Car Parking (Total)
Existing Church	280 sqm	17 spaces (formal)
Development Proposal – Stage 1	280 sqm	28 spaces
Development Proposal – Stage 2	280 sqm	28 spaces
Development Proposal – Stage 3	280 sqm	97 spaces
Development Proposal – Stage 4	718 sqm (+438sqm)	128 spaces (+111 spaces)

It is noted that Stage 1, Stage 2 and Stage 3 do not correspond to any increased to the church auditorium or seating areas, with Stage 4 including the delivery of an auditorium extension.

The proposed development layout and staging plan is provided in **Appendix A**.

Existing Network

Road Network

The roads adjacent to the site include Boston Road, Tilley Road, Old Cleveland Road and Archer Street. A summary of the surrounding road network is shown in Figure 2.

Figure 2 – Road Network Summary



Source: Nearmap.com (Aerial dated 24 August 2025)

Active and Public Transport

A review has been undertaken of the existing active travel and pedestrian infrastructure surrounding the subject site. The review indicates that pedestrian paths are provided along at least one side of Tilley Road and Archer Street. Nearest cycle path is provided along Old Cleveland Road. A summary of the pedestrian network, cycle paths and bus stop locations surrounding the subject site are provided in Figure 2, with bus services summarised in Table 2.

Table 2 – Public Transport Services

Nearest Stop	Route Number	Route Frequency - Weekday	Route Frequency - Weekend
Old Cleveland Rd near Bacton Rd, Chandler	250, 251, 270, 275	20 - 30 min (typical)	1 hour
	265, 267	30min - 1hr (typical)	N/A
Old Cleveland Rd near Archer Street, Chandler	250, 251, 270, 275	20 - 30 min (typical)	1 hour
	265, 267	30min - 1hr (typical)	N/A
The Sleeman Centre, stop C, D Chandler	N250, 243	30 min (typical)	1 hour
	273	1 hour	N/A

Transport Provisions

Car Parking Provisions

The statutory car parking requirements for the 'Place of Worship' land use is set out within Council's City Plan 2014 'Transport Access Parking and Servicing' Planning Scheme Policy (PSP). A review of the statutory car parking rates indicates the following requirements:

- 'Place of Worship' - 10 spaces per 100m² auditorium and seating area

Application of these carparking rates to the proposed development yields (as summarised in Table 1) has been summarised in Table 3 below.

Table 3 – Statutory Parking Requirement

Development Stage	Development Yield	Required Car Parking Rate	Required Car Parking	Provided Car Parking
Stage 1 – Stage 3	280sqm auditorium	10 per 100sqm	28 spaces	28 spaces
Stage 4	718sqm auditorium	10 per 100sqm	72 spaces	128 spaces

The proposed development layout includes the following car parking provisions

- Stage 1, Stage 2 and Stage 3 – 28 spaces
- Stage 4 – 128 car parking spaces.

These provisions exceed Council's minimum requirements and is considered to be acceptable.

Bicycle Parking Provisions

The statutory bicycle parking requirement for the proposed development land use is not specified within the 'Transport Access Parking and Servicing' code of Council's planning policy scheme. Therefore, no bicycle parking is required for the development

Servicing Provisions

Council Requirements

The statutory servicing requirements for the proposed development land uses are set out within the 'Transport Access Parking and Servicing' code of Council's PSP. A review of the statutory servicing requirements indicates that servicing of vehicles up to a Large Rigid Vehicle (LRV) is required for the 'place of worship' land use.

Proposed Arrangements

Based on information provided by the existing New Day Church, the site is primarily serviced by a Refuse Collection Vehicle (RCV), with servicing by other vehicles (up to a LRV design vehicle) to be highly infrequent. As such, the proposed servicing arrangements include a dedicated loading bay located to the northeast of

the site, accommodating vehicles up to and including a 10.3m RCV adjacent to the Boston Road frontage. It is noted that the RCV loading bay partially overhangs the circulation aisle, limiting access to one-lane, two-way during operations by an RCV design vehicle.

Given the infrequency of LRV loading, a dedicated LRV loading bay has not been provided, with temporary loading to be accommodated within the mid-site parking area.

Suitability of Servicing Arrangements

Given the typical vehicle trip generation profiles associated with the church, the church facilities (including carpark) will have very low vehicle trip generation outside of services and event times. As such, it is considered reasonable for servicing provisions to temporarily reduce vehicle movements to a single lane.

It is noted that on-site loading for the LRV is expected to be significantly infrequent and is only expected to occur on a scheduled basis, outside of any events or services, and can be safely accommodated within the circulation aisle without limiting vehicle access.

The swept path assessment demonstrates that the design vehicles can enter the site in a forward direction, undertake necessary manoeuvring, and exit the site in a forward direction. The swept path assessment for these design vehicles is provided in **Attachment B**. With consideration of the above, the proposed servicing arrangements are acceptable.

Design Considerations

Vehicle Access Arrangements

Based on the requirements of Council's TAPS PSP, a 7m wide type B2 driveway crossover is required. The development layout includes the provision of a 9.0m wide type B2 driveway crossover onto Boston Road, accommodating all movements for passenger vehicles and service vehicles. This provision exceeds the Council's minimum requirements and is considered to be acceptable.

A swept path assessment has been undertaken to confirm the suitability of the proposed driveway crossover to accommodate one-way manoeuvring of a refuse collection vehicle (design vehicle), and two-way manoeuvring of a B99 passenger vehicle. This swept path assessment is provided in **Appendix B**.

A review of the available sight distance has been undertaken in accordance with the requirements of the relevant Australian Standards (AS2890.1, AS2890.2). Based on the frontage speed of 50km/h, a minimum gap sight distance of 90m is required. A review of the available sight distances along Boston Road indicates that a distance greater than 90m can be achieved along Boston Road toward oncoming vehicles. Given these arrangements exceed the minimum requirements, the available sight distance is considered to be acceptable. With consideration of the above, the proposed access arrangements are acceptable.

Design Review

The transport elements of the proposed development have been reviewed against the requirements of the 'Transport Access Parking and Servicing' code of Council's PSP, relevant Australian Standards (AS2890.1, AS2890.2 and AS2890.6) and good transport engineering practice. Details of the review are provided below in Table 4.

Table 4 – Design Review

Design Aspect	Statutory Requirement	Provision	Compliance
Staff Car Parking (Class 1A)			
Parking Space Width	2.4m	2.4m – 2.6m	Compliant
Parking Space Length – Regular	5.4m	5.4m	Compliant

Design Aspect	Statutory Requirement	Provision	Compliance
<i>Parking Space Length – Tandem</i>	10.8m	10.8m	Compliant
<i>Parking Aisle Width</i>	5.8m	6.0m	Compliant
Visitor Car Parking (Class 3)			
<i>Parking Space Width</i>	2.6m	2.6m	Compliant
<i>Parking Space Length</i>	5.4m	5.4m	Compliant
<i>Parking Aisle Width</i>	5.8m	6.0m	Compliant
PWD Car Parking (Class 4)			
<i>Parking Space Width</i>	2.4m space + 2.4m shared area	2.4m space + 2.4m shared area	Compliant
<i>Parking Space Length</i>	5.4m	5.4m	Compliant
<i>Parking Aisle Width</i>	6.2m	6.2m (min.)	Compliant
Adjacent Structures			
<i>Clearance to adjacent Structures</i>	0.3m	0.3m (min.)	Compliant
RCV Loading Bay			
<i>Service Bay Length</i>	10.3m	10.3m	Compliant
<i>Service Bay Width</i>	3.5m	4.3m	Compliant
<i>Service Aisle Width</i>	6.5m	6.5m	Compliant

It is noted that the proposed carparking is to be delivered under a staged arrangement. It is understood that the staged carpark sections will be provided compliant with relevant Australian Standards. It is expected that compliance of each staged carpark section with the relevant Australian Standards can be addressed by way of a suitably worded approval condition.

Traffic Impacts

Preamble

The operation of the key intersections has been assessed using SIDRA. This assessment has been completed to compare the operation of the key intersections adjacent to the development site under the existing conditions, 'existing approval' scenario and 'development' scenario for both the year of opening (2027) and for a 10-year design horizon (2037). These assessments have overlaid the expected vehicle trip generation on the existing background traffic demands to determine the performance of the adjacent road network.

In addition to the above, a net delay assessment has been undertaken in accordance with the requirements of the TMR Guide to Traffic Impact Assessments (GTIA) for the state-controlled road intersection. A net delay assessment identifies the impact of the development generated traffic on the state-controlled Old Cleveland Road / Tilley Road intersection. This assessment calculates the delay impacts to the existing vehicles once the development traffic has been added to the network. Based on the requirements of the GTIA, our assessment is required for the year of opening only (2027).

Background Traffic

A traffic survey was conducted on the adjacent road network on Saturday 2nd November 2025 between 8:00AM and 12:00PM to coincide with the busiest regular service of the New Day Church. Traffic survey was undertaken at the following intersections:

- Old Cleveland Road / Tilley Road
- Old Cleveland Road / Archer Street
- Boston Road / Tilley Road
- Boston Road / Archer Street
- Tilley Road / Site Access

The road peak hour period was recorded in the survey results as 11:00AM – 12:00PM. Survey Results have been provided as **Appendix C**.

Site Visit & Observations

A detailed site visit was undertaken on Sunday, 2 November 2025 between 8:00AM and 12:00AM to coincide with the busiest regular service of the New Day Church.

Design Horizons & Traffic Growth Rate

Based on information provided by the project team, the development is expected to be completed by 2027. A 'year of opening' has therefore been adopted as 2027 and 2037 projected as the '10-year design horizon'.

A review of available AADT data ('Average Annual Daily Traffic for Queensland State Controlled Roads 2014 to 2024', DTMR) for Old Cleveland Road proximate to Tilley Road has been undertaken. The results of the review indicate that for the previous 5-year and 10-year periods, a growth rate of less than 0.5% per year was observed. As such, a nominal growth rate of 0.5% up to the 2027 and 2037 design horizons has been applied to background traffic demands.

Vehicle Trip Generation

An estimate of the vehicle trip generation for the proposed development has been calculated based on observations undertaken during the site visit, in which an average vehicle occupancy of 2.3 persons per vehicle was observed. Application of this vehicle trip generation rate to the proposed maximum attendance has been summarised in Table 5.

Table 5 – Vehicle Trip Generation

Description	Attendees	Trip Generation Rate	Trip Generation Total
Existing Approval	60 persons	2.3 persons / veh.	26 vehicles
Maximum Capacity	350 persons	2.3 persons / veh.	152 vehicles (+126 vehicles)

The proposed maximum capacity is expected to result in an increase of 126 vehicles (152 vehicles total) compared to the existing approval.

Distribution and Assignment

In / Out Splits

Based on the existing church operations, vehicle arrivals and departures are not expected to occur within the same peak hour (with the typical service running for 2 hours between 9:00AM and 11:00AM). As such, the inbound (arrival) and outbound (departure) movements have been assessed separately, overlaid on the weekend peak hour.

Directional Distribution

The directional distribution and assignment of vehicle trips generated by the development will be influenced by the configuration of the adjacent transport network and the accessibility of travel routes. The adopted vehicle trip distributions and assignment of vehicle trips on the external road network are summarised as follows for the inbound and outbound peak hours:

- 50% to / from the west of the site via Old Cleveland Road (and Tilley Road)
- 25% to / from the north of the site via Tilley Road
- 25% to / from the east of the site via Old Cleveland Road (in via Tilley Road intersection, out via Archer Street intersection)

These directional distributions and traffic volumes have been applied to the existing road network through a Network Flow Diagram.

Traffic Impact Analysis

Existing Conditions (2025)

The existing operating conditions of the intersections have been assessed to establish the baseline conditions based on on-site observations. The result of this assessment has been provided in Table 6, with detailed SIDRA results provided in **Appendix D**.

Table 6 – SIDRA Results – Existing Conditions (2025)

Intersection	Movement	DOS	Average Delay (sec)	95 th Percentile Queue (m)
Old Cleveland Road / Tilley Road	Peak Hour	0.72	47	243
Old Cleveland Road / Archer Street	Peak Hour	0.43	< 1	0
Boston Road / Tilley Road	Peak Hour	0.35	1	2
Boston Road / Archer Street	Peak Hour	0.06	2	1
Tilley Road / Site Access	Peak Hour	0.02	< 1	0

The result of the assessment indicates that all intersections operate within their practical performance limits during 'Existing Conditions (2025)' scenarios.

Year of Opening (2027)

The comparison between intersection performance between the 'Existing Approval' peak hour scenario and the 'Development' scenarios for the 'year of opening' is provided in Table 7, with detailed SIDRA results provided in **Appendix D**.

Table 7 – SIDRA Results – Year of Opening (2027)

Intersection	Movement	Existing Approval Scenario			Development Scenario		
		DOS	Avg Delay (sec)	95 th Percentile Queue (m)	DOS	Avg Delay (sec)	95 th Percentile Queue (m)
Old Cleveland Road / Tilley Road	Arrival	0.73	47	244	0.73	47	246
	Departure	0.73	48	245	0.78	52	258
Old Cleveland Road / Archer Street	Arrival	0.43	< 1	0	0.44	< 1	0
	Departure	0.43	< 1	0	0.43	< 1	0
Boston Road / Tilley Road	Arrival	0.37	1	3	0.47	3	16
	Departure	0.35	1	2	0.35	2	8

Intersection	Movement	Existing Approval Scenario			Development Scenario		
		DOS	Avg Delay (sec)	95th Percentile Queue (m)	DOS	Avg Delay (sec)	95th Percentile Queue (m)
Boston Road / Archer Street	Arrival	0.06	2	1	0.06	2	1
	Departure	0.06	3	1	0.07	3	2
Tilley Road / Site Access	Arrival	0.04	2	1	0.11	4	4
	Departure	0.02	1	1	0.11	1	3

The result of the assessment indicates that all intersections are expected to operate within their practical performance limits during 'year of opening' for both the 'Existing Approval' and 'Development' scenarios.

10-Year Design Horizon (2037)

The comparison between intersection performance between the 'Existing Approval' scenario and the 'Development' scenarios for a '10-year design horizon' following completion of the expanded scenario is provided in Table 8, with detailed SIDRA results provided in **Appendix D**.

Table 8 - SIDRA Results – 10 Year Design Horizon (2037)

Intersection	Movement	Existing Approval Scenario			Development Scenario		
		DOS	Avg Delay (sec)	95th Percentile Queue (m)	DOS	Avg Delay (sec)	95th Percentile Queue (m)
Old Cleveland Road / Tilley Road	Arrival	0.78	49	268	0.78	49	269
	Departure	0.78	50	268	0.84	57	296
Old Cleveland Road / Archer Street	Arrival	0.45	0.3	0	0.46	0.3	0
	Departure	0.45	0.3	0	0.45	0.4	0
Boston Road / Tilley Road	Arrival	0.39	1	4	0.49	3	18
	Departure	0.37	1	2	0.37	2	9
Boston Road / Archer Street	Arrival	0.06	2	1	0.06	2	1
	Departure	0.06	3	1	0.07	3	2
Tilley Road / Site Access	Arrival	0.04	2	1	0.11	4	4
	Departure	0.04	1	1	0.13	2	4

The results of the assessment indicates that all intersections are expected to operate within their practical performance limits during '10-year design horizon' for both the 'Existing Approval' and 'Development' scenarios.

Net Delay Assessment

As outlined in TMR's GTIA, a net delay assessment is required to understand the impact of the development generated traffic on the state-controlled intersections. This assessment calculates the delay impacts to the existing vehicles once the development traffic has been added to the network.

The net delay assessment for the state-controlled Old Cleveland Road / Tilley Road signalised intersection is outlined in Table 9.

Table 9 – Old Cleveland Road / Tilley Road – Net Delay Assessment (2027)

Scenario	Baseline Delay (veh.sec)	Development Delay (veh.sec)	Net Increase (veh.sec)	Percentage (%)
Inbound	211,170	207,067	- 4,102	-1.9%
Outbound	213,342	231,476	18,134	8.5%
Total	424,512	438,544	14,032	3.3%

The results of the net delay assessment shows that the addition of the development traffic results in a combined delay impact of 3.3% to the existing vehicle demands. This is less than the 5.0% threshold which would require mitigation and is considered to be acceptable.

Summary

This traffic impact assessment has been prepared to assess the traffic and transport impacts of the proposed expansion to the existing New Day Church, located at 577 Boston Road, Chandler. The key findings are summarised below:

- The development proposal includes the staged delivery of additional buildings and on-site facilities to support the New Day church, including an increase to the church auditorium / seating area of 718 square metres (+438 square metres) and a maximum person capacity of 350 persons (+290 persons).
- The development proposed a car parking supply of 128 car parking spaces, exceeding the minimum statutory requirement of 72 car parking spaces.
- The proposed car parking layout is provided generally in accordance with requirements of Council's TAPS PSP, relevant Australian Standards, and good transport engineering practice.
- The layout accommodates a refuse collection vehicle (RCV) access. Swept path analysis confirms that a 12.5m Large Rigid Vehicle and a 10.3m Council RCV can enter the site, manoeuvre and depart the site in a forward direction.
- The traffic capacity of the surrounding road network has been assessed. The results of the assessment indicate that the additional traffic resulting from the expansion will not result in any material deterioration of intersection performance on the adjacent intersections.
- A net delay assessment indicates that the proposed development will result in an increased delay at the Old Cleveland Road / Tilley Road intersection of 3.3% and does not require mitigation.

Based on the assessment contained within this report, Urbis see no reasons why the development should not be approved from a traffic engineering perspective.

Kind regards,



Andrew Tierney
Associate Director // RPEQ#34680
+61 7 3007 3585
atierney@urbis.com.au

Appendix A – Development Plans

Appendix B – Swept Path Assessment

Appendix C – Traffic Survey

Appendix D – SIDRA results summary

Appendix A – Development Plans

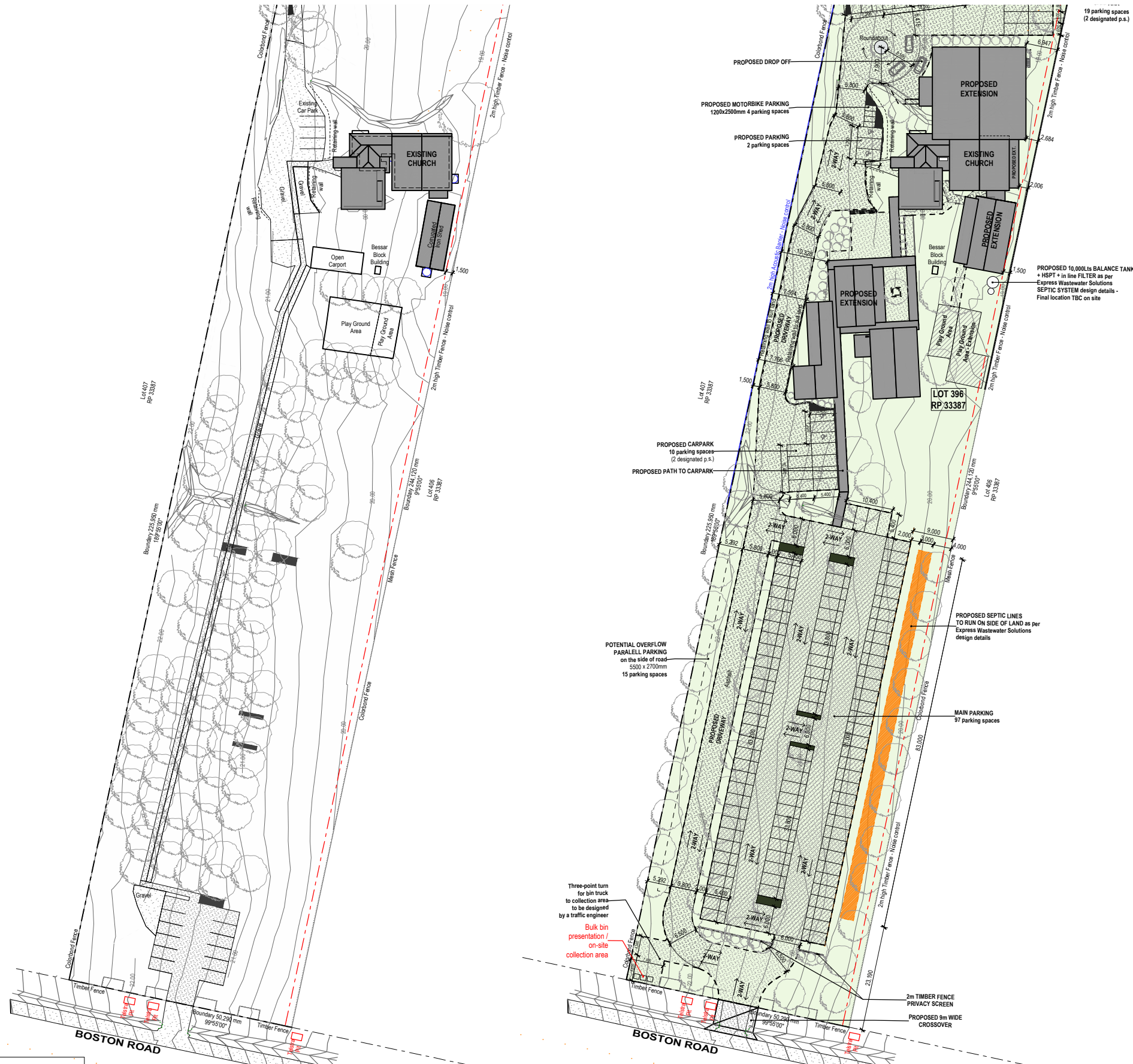

Proposed Landscape	4,643.20 m ²
Concrete/Driveway/Parking	5,188.30 m ²
Proposed Carpark:	
Main carpark	93 parking spaces
Extension parking	10 parking spaces
Ex. building parking	2 parking spaces
Rear carpark	19 parking spaces
TOTAL	122 parking spaces
Including	4 designated parking
18 volunteering parking	
+ 4 motorbike parking	
Parallel parking to the side of the road (potential overflow)	+15 parking spaces

SITE STATISTICS
 Lot 396 RP 33387
 Council: BCC

PROPOSED SITE CALCULATIONS
 Site Area: 1.182 ha
 Site cover: 1,816.25 m² (15.36 %)
 Enclosed: 1,059.95 m²
 Unenclosed: 756.35 m²

SURVEY NOTE:
 Site information including building location and existing contours obtained from Site Surveys drawing ref. 6971.02_DET.RevA

Please note: Additional surveys will be required at construction stage (Identification (Boundary Pegging), setout, height certifications, etc.)

SITE PLAN LEGEND:

- Existing dwelling
- Proposed extension / new build

SURVEY PLAN LEGEND:
 * services location referenced from survey plans

- Boundary
- Contours & contour heights
- Fence - boundary fence
- Fence - pool fence
- Gas line (GM - gas meter)
- Overhead communications line
- Overhead electrical line
- Sewer main line & house connection
- Stormwater line
- Underground communications line
- Underground electrical line
- Water line (WM - water meter)

PRELIMINARY PLANS
NOT FOR CONSTRUCTION
 This drawings is to be considered preliminary until this disclaimer is removed by Urban Design Solutions

UDS_Logo_Simple 32EFA19E.jpg

Another Quality Design
 phone | +61 7 3399 3469
 email | office@UrbanDesignSolutions.com.au
 web | www.UrbanDesignSolutions.com.au
 post | PO Box 9122, Wynnum Plaza Qld 4178
 QBCC LICENCE NO. I 1177769

Urban Design Solutions retains Copyright © and all intellectual property rights in respect to this document. Reproduction of the whole or part of this document is an infringement of copyright. The recipient indemnifies Urban Design Solutions against all claims resulting from use of this document for any purpose other than its intended use. Reuse of this document or unauthorised changes to this document are prohibited unless written permission is gained from Urban Design Solutions.
 Verify dimensions and levels on site before setting out.
 Do not scale from drawings.

Consultant List:
Certifier: #Consultant - Certifier
Hydraulic Engineer: N/A
Planning Consultant: Urbis
Structural Engineer: Walker Engineering
Surveyor: Arnold Development Consultants
Builder: Crosscut Projects

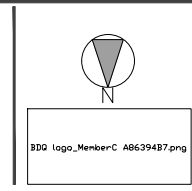

Issue	Date	Description
01	16/2/2026	DA PLANS

CHURCH EXTENSION
 Client:
NEW DAY CHURCH
 Project address:
**577 Boston Road,
 Chandler, QLD, 4155**

Drawing Title: EXISTING AND PROPOSED SITE PLAN		
Project N°: Q820	Drawing N°: WD300	Issue: 01
Drawn by: LL	Scale: 1:1000 @ A3	Plot date: 20/4/2026

Appendix B – Swept Path Assessment

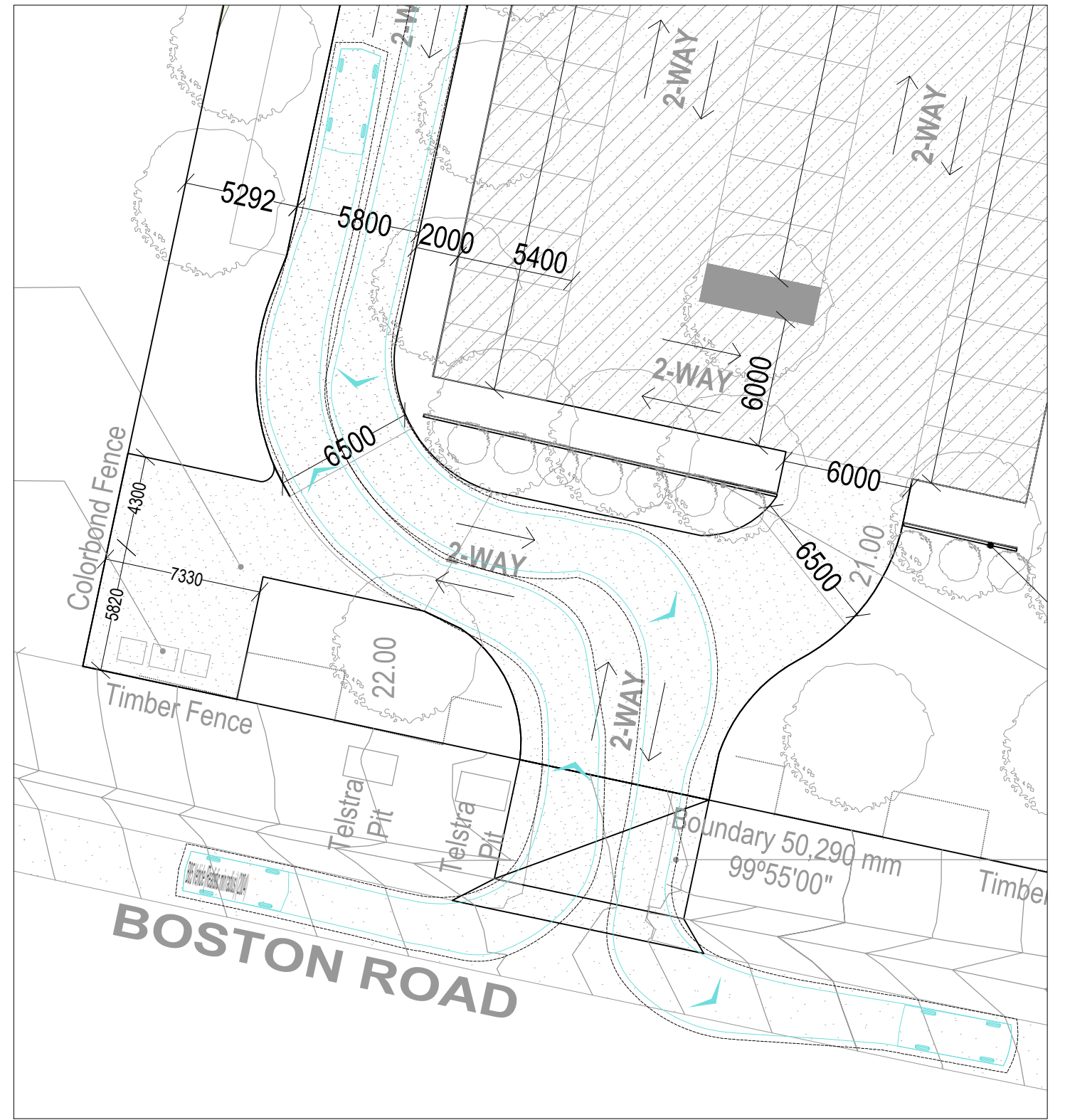
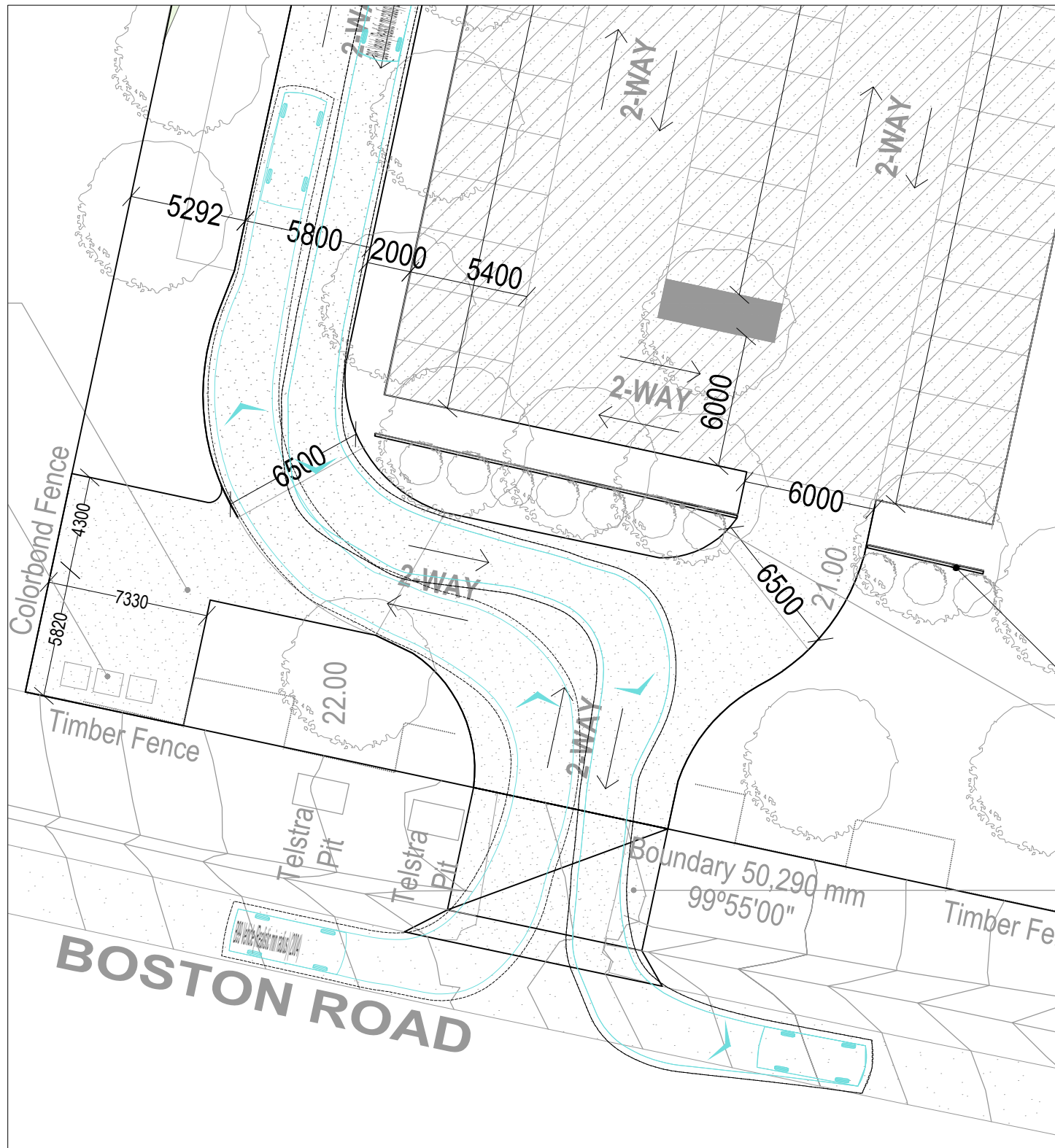

300MM CLEARANCE ENVELOPE

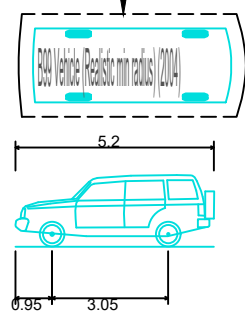

B99 VEHICLE (Realistic min radius)

Overall Length	5.200m
Overall Width	1.940m
Overall Body Height	1.878m
Min Body Ground Clearance	0.272m
Track Width	1.840m
Lock-to-lock time	4.00s
Curb to Curb Turning Radius	6.250m

**PRELIMINARY ADVICE ONLY
NOT FOR CONSTRUCTION
22/04/2026**

**ALL DRAWINGS ARE DESIGNED TO
BE PRINTED AND READ IN COLOUR**

IT IS THE CONTRACTORS' RESPONSIBILITY TO
PRINT DRAWINGS IN COLOUR TO AVOID ANY
POTENTIAL DISCREPANCIES IF DRAWINGS
ARE PRINTED IN BLACK AND WHITE



577 BOSTON ROAD, CHANDLER
B99 SWEEP PATHS

Level 32, 300 George Street | Brisbane QLD 4000 Australia | +61 7 3007 3800 | URBIS Pty Ltd | ABN 50 105 256 228

REV	DESCRIPTION	M.B.	A.T.	DWN	CHK	DATE
1	SWEEP PATHS					22/04/2026

DISCLAIMER
Copyright by Urbis Pty Ltd. This drawing or parts thereof may not be reproduced for any purpose or used for another project without the consent of Urbis. The plan must not be used for ordering, supply or installation and no reliance should be placed on this plan for any financial dealing of the land. This plan is conceptual and is for discussion purposes only and subject to further detail study. Council approval, engineering input, and survey. Cadastral boundaries, areas and dimensions are approximate only. Written figured dimensions shall take preference to scaled dimensions.

CLIENT
New Day Church, Brisbane

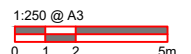

PROJECT NO. P0046052
DRAWING NO. 01
DATE 22/04/2026
REVISION -

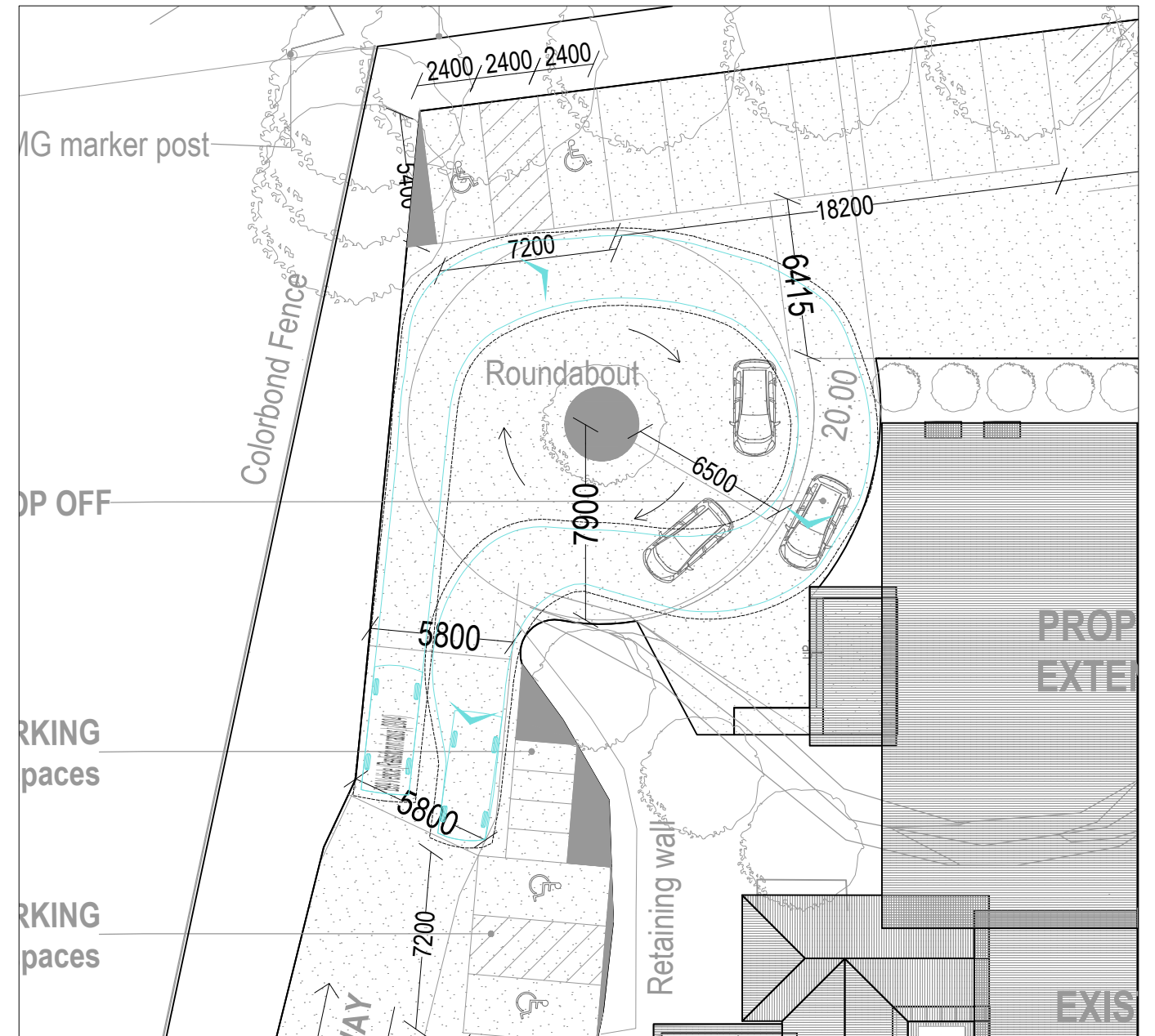
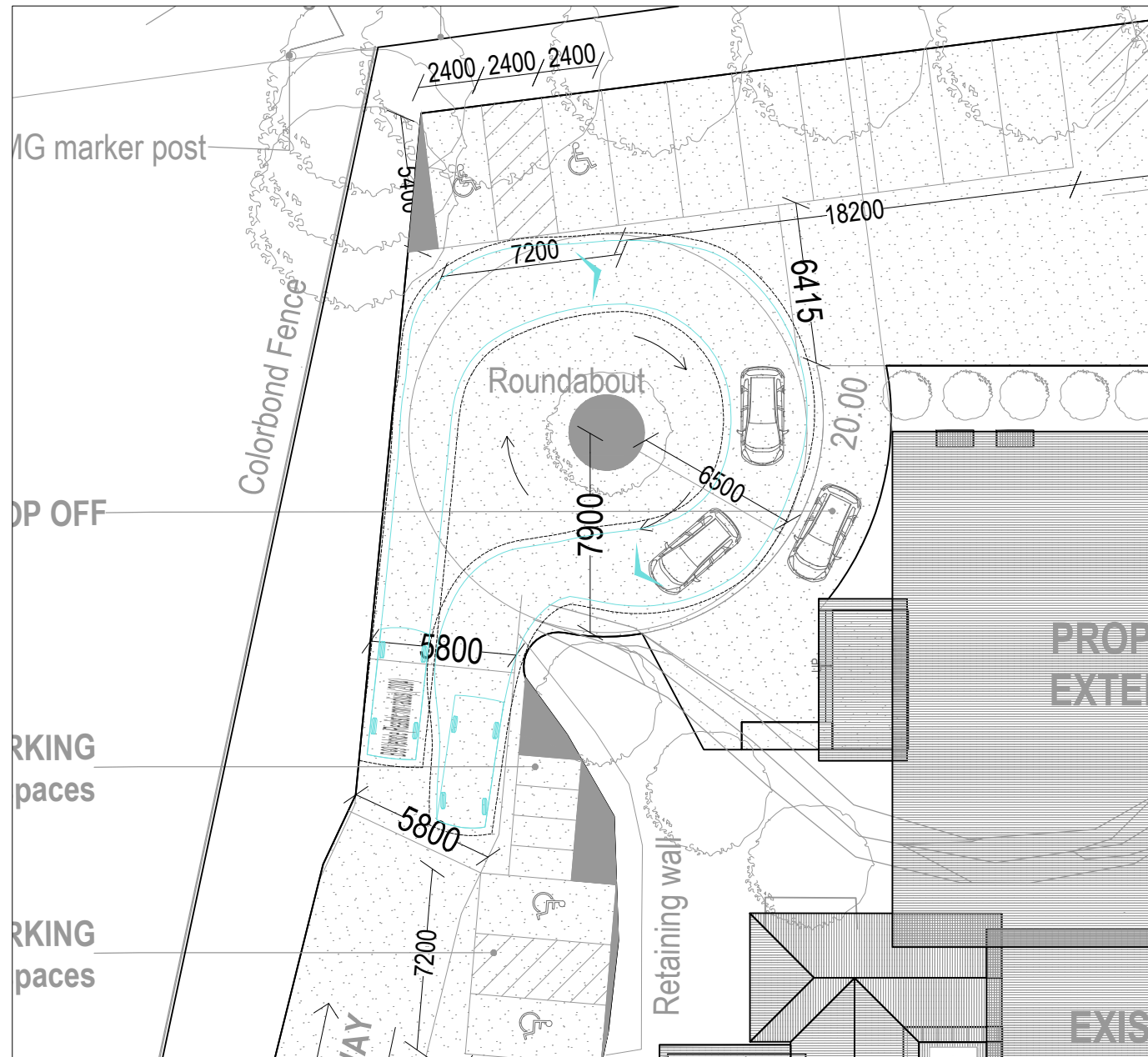

300MM CLEARANCE ENVELOPE

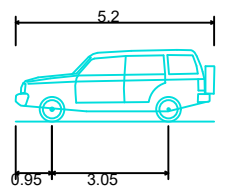

B99 VEHICLE (Realistic min radius)

Overall Length	5.200m
Overall Width	1.940m
Overall Body Height	1.878m
Min Body Ground Clearance	0.272m
Track Width	1.840m
Lock-to-lock time	4.00s
Curb to Curb Turning Radius	6.250m

**PRELIMINARY ADVICE ONLY
NOT FOR CONSTRUCTION
06/02/2026**

**ALL DRAWINGS ARE DESIGNED TO
BE PRINTED AND READ IN COLOUR**

**IT IS THE CONTRACTORS' RESPONSIBILITY TO
PRINT DRAWINGS IN COLOUR TO AVOID ANY
POTENTIAL DISCREPANCIES IF DRAWINGS
ARE PRINTED IN BLACK AND WHITE**



577 BOSTON ROAD, CHANDLER
B99 SWEEP PATHS

Level 32, 300 George Street | Brisbane QLD 4000 Australia | +61 7 3007 3800 | URBIS Pty Ltd | ABN 50 105 256 228

REV	DESCRIPTION	M.B.	A.T.	DWN	CHK	DATE
	SWEPT PATHS					22/04/2026

DISCLAIMER
Copyright by Urbis Pty Ltd. This drawing or parts thereof may not be reproduced for any purpose or used for another project without the consent of Urbis. The plan must not be used for ordering, supply or installation and no reliance should be placed on this plan for any financial dealing of the land. This plan is conceptual and is for discussion purposes only and subject to further detail study, Council approval, engineering input, and survey. Cadastral boundaries, areas and dimensions are approximate only. Written figured dimensions shall take preference to scaled dimensions.

CLIENT
New Day Church, Brisbane

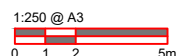

PROJECT NO. P0046052
DRAWING NO. 02
DATE 22/04/2026
REVISION -

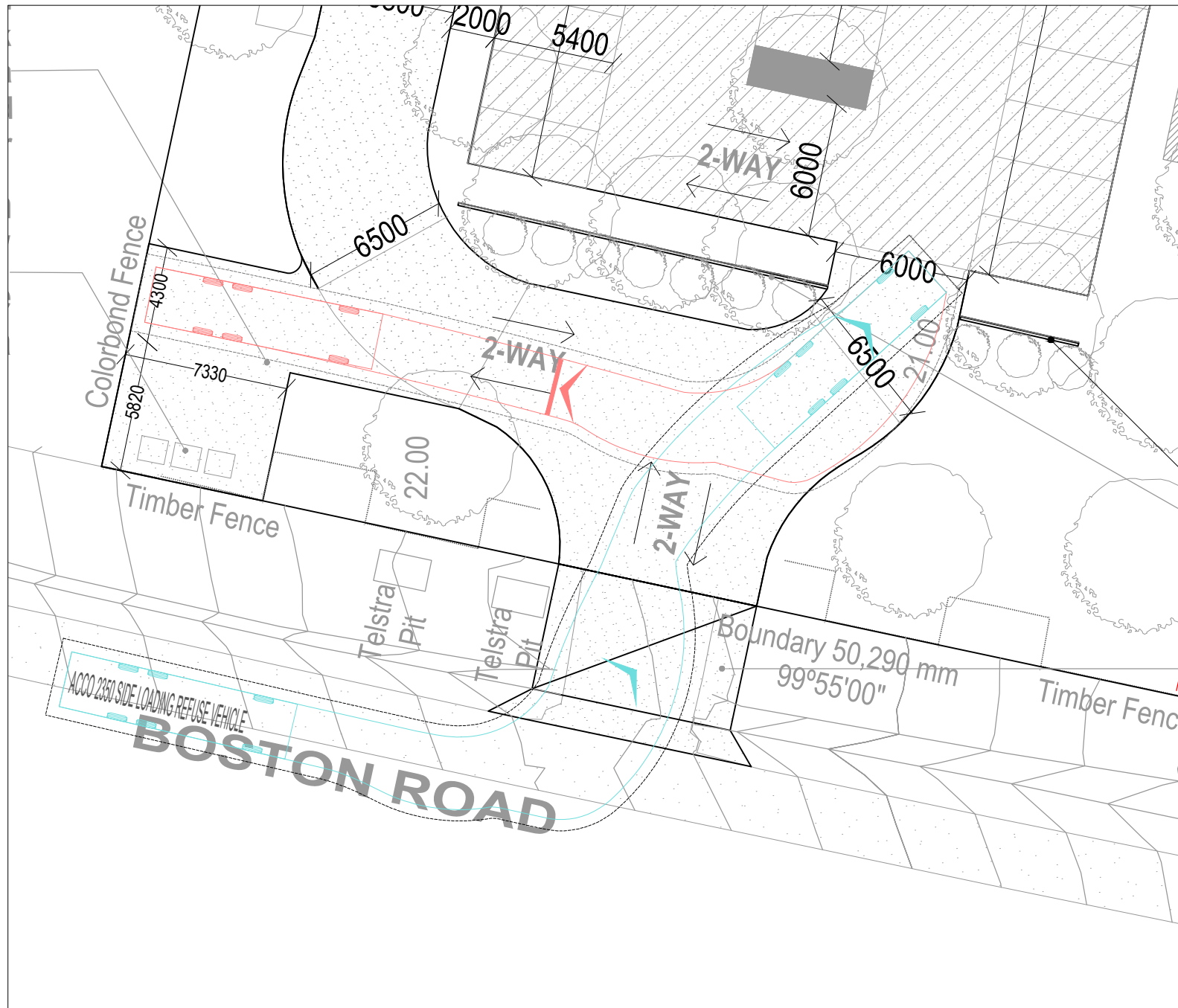

INGRESS

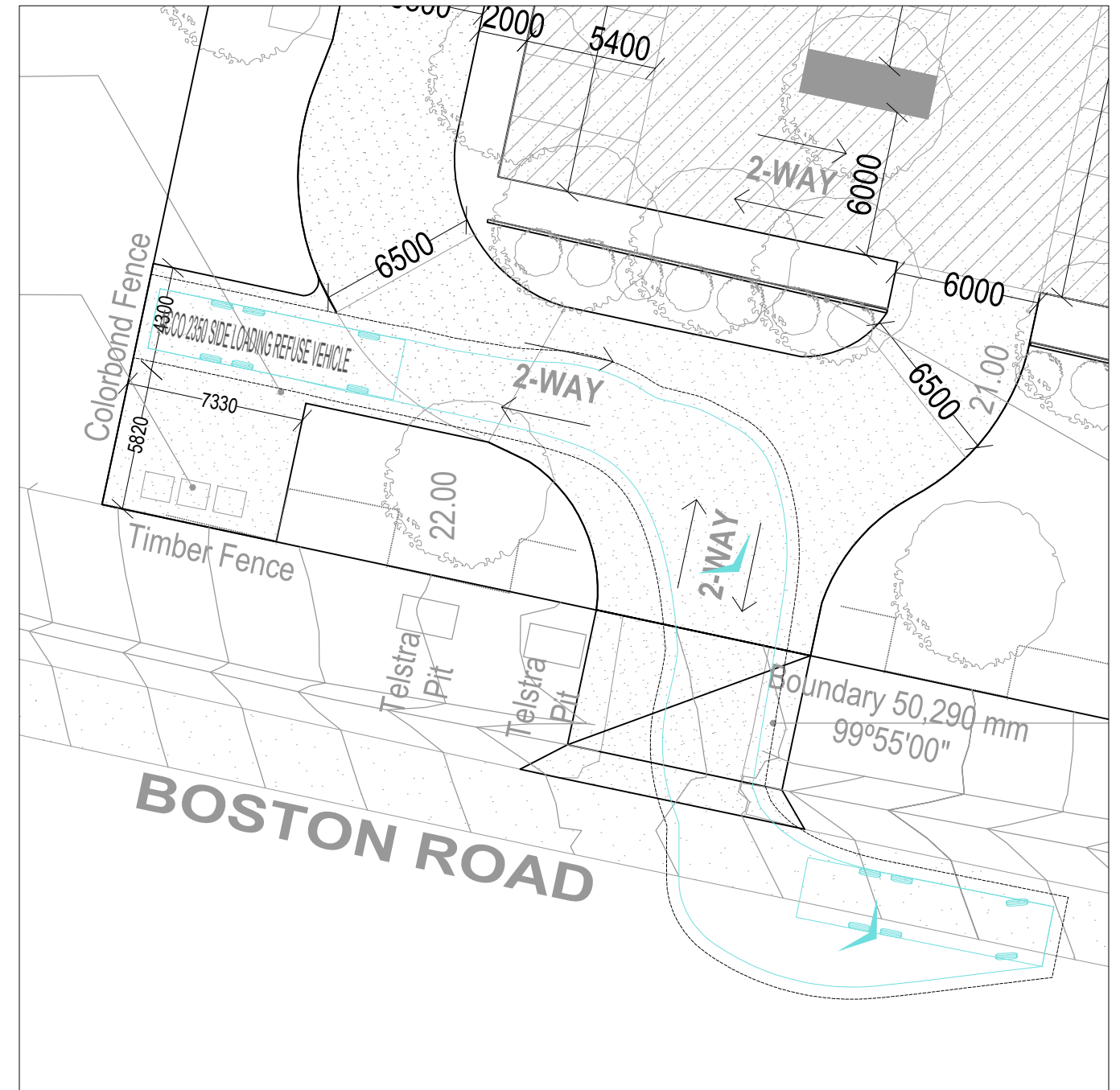

EGRESS

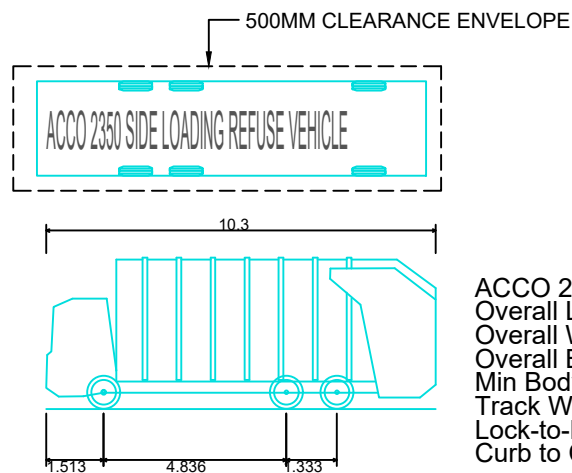

ACCO 2350 SIDE LOADING REFUSE VEHICLE
 Overall Length 10.300m
 Overall Width 2.500m
 Overall Body Height 4.000m
 Min Body Ground Clearance 0.304m
 Track Width 2.500m
 Lock-to-lock time 4.00s
 Curb to Curb Turning Radius 9.000m

**PRELIMINARY ADVICE ONLY
 NOT FOR CONSTRUCTION
 22/04/2026**

**ALL DRAWINGS ARE DESIGNED TO
 BE PRINTED AND READ IN COLOUR**
 IT IS THE CONTRACTORS' RESPONSIBILITY TO
 PRINT DRAWINGS IN COLOUR TO AVOID ANY
 POTENTIAL DISCREPANCIES IF DRAWINGS
 ARE PRINTED IN BLACK AND WHITE



577 BOSTON ROAD, CHANDLER
RCV SWEEP PATHS

Level 32, 300 George Street | Brisbane QLD 4000 Australia | +61 7 3007 3800 | URBIS Pty Ltd | ABN 50 105 256 228

REV	DESCRIPTION	M.B.	A.T.	22/04/2026	DWN	CHK	DATE
-	SWEPT PATHS						

DISCLAIMER
 Copyright by Urbis Pty Ltd. This drawing or parts thereof may not be reproduced for any purpose or used for another project without the consent of Urbis. The plan must not be used for ordering, supply or installation and no reliance should be placed on this plan for any financial dealing of the land. This plan is conceptual and is for discussion purposes only and subject to further detail study, Council approval, engineering input, and survey. Cadastral boundaries, areas and dimensions are approximate only. Written figured dimensions shall take preference to scaled dimensions.

CLIENT
New Day Church, Brisbane



PROJECT NO. P0046052
 DRAWING NO. 03
 DATE 22/04/2026
 REVISION -

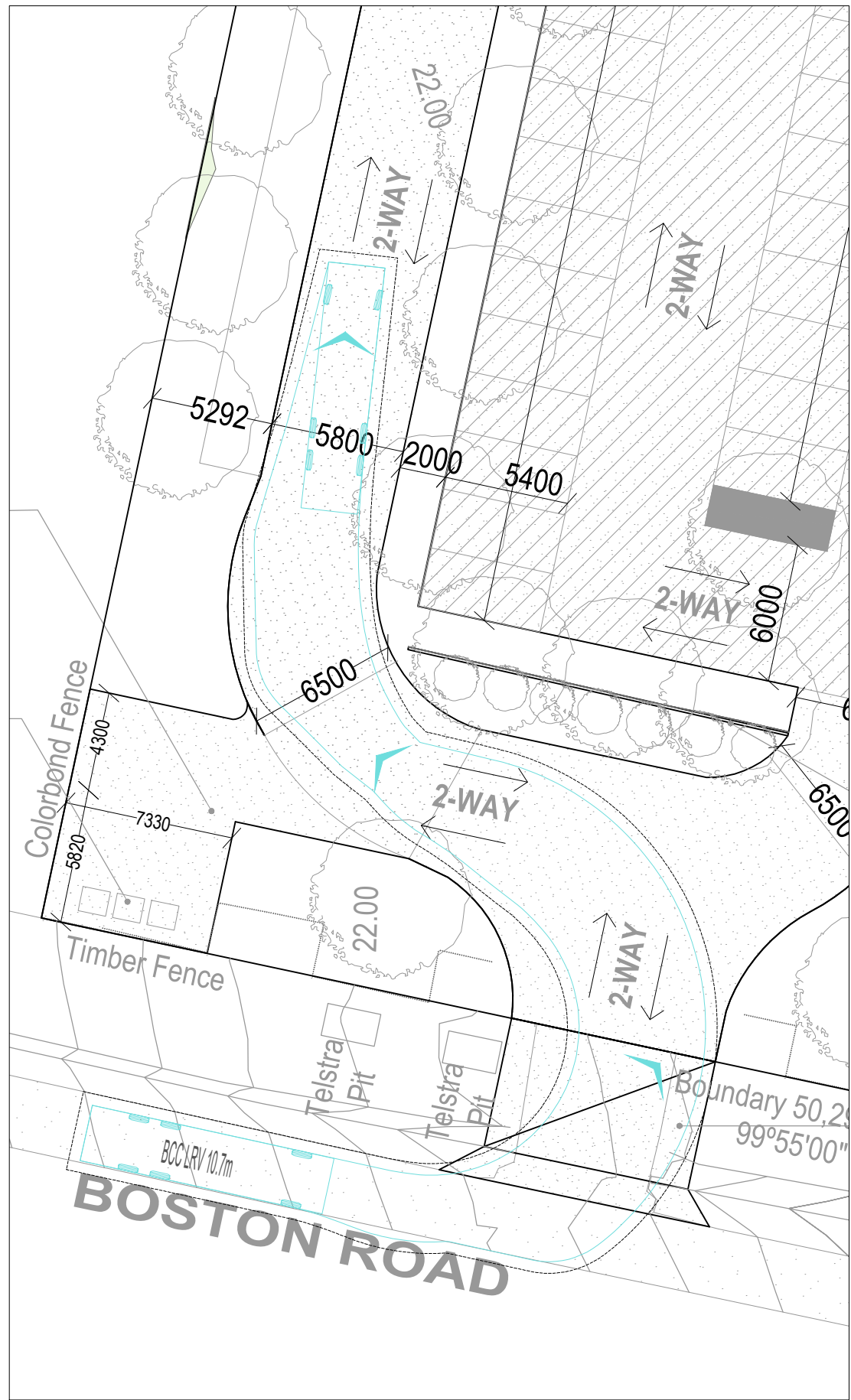

INGRESS

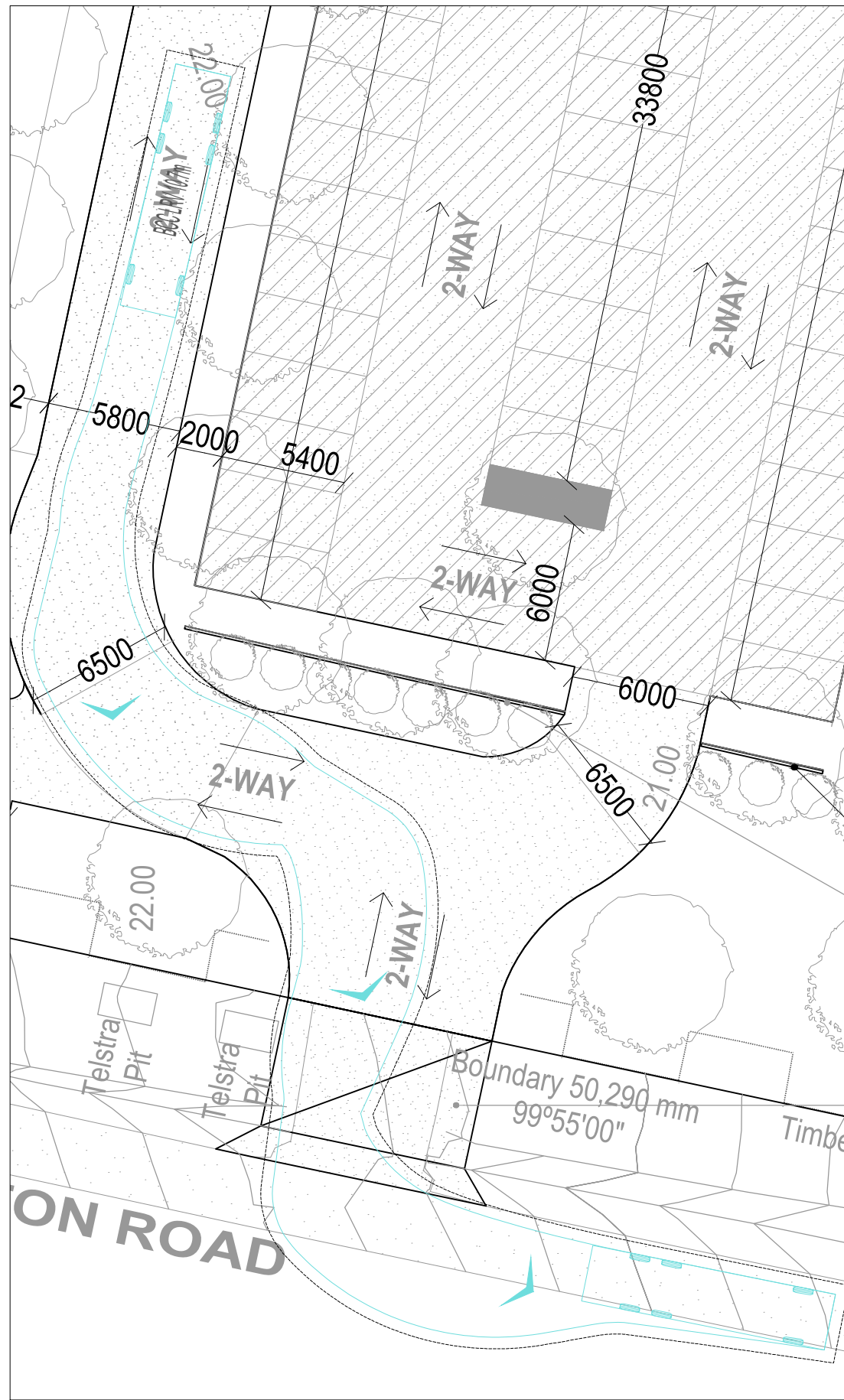

EGRESS

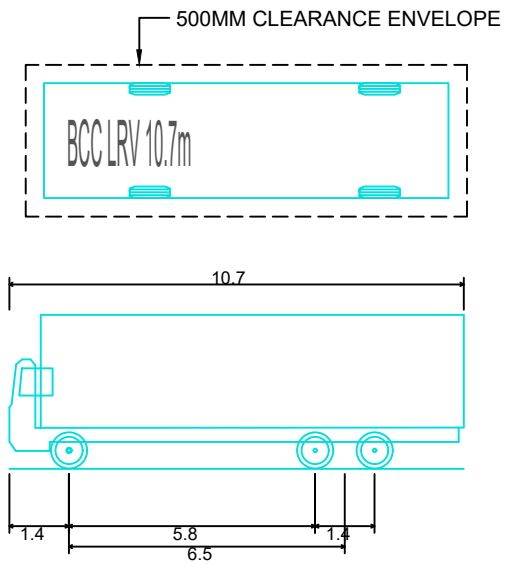

BCC LRV 10.7m	
Overall Length	10.700m
Overall Width	2.450m
Overall Body Height	3.623m
Min Body Ground Clearance	0.419m
Track Width	2.450m
Lock-to-lock time	4.00s
Curb to Curb Turning Radius	11.000m

**PRELIMINARY ADVICE ONLY
NOT FOR CONSTRUCTION
22/04/2026**

**ALL DRAWINGS ARE DESIGNED TO
BE PRINTED AND READ IN COLOUR**

**IT IS THE CONTRACTORS' RESPONSIBILITY TO
PRINT DRAWINGS IN COLOUR TO AVOID ANY
POTENTIAL DISCREPANCIES IF DRAWINGS
ARE PRINTED IN BLACK AND WHITE**



577 BOSTON ROAD, CHANDLER
LRV SWEEP PATHS - ACCESS

Level 32, 300 George Street | Brisbane QLD 4000 Australia | +61 7 3007 3800 | URBIS Pty Ltd | ABN 50 105 256 228

REV	DESCRIPTION	M.B.	A.T.	22/04/2026	DWN	CHK	DATE
1	SWEPT PATHS						

DISCLAIMER
Copyright by Urbis Pty Ltd. This drawing or parts thereof may not be reproduced for any purpose or used for another project without the consent of Urbis. The plan must not be used for ordering, supply or installation and no reliance should be placed on this plan for any financial dealing of the land. This plan is conceptual and is for discussion purposes only and subject to further detail study, Council approval, engineering input, and survey. Cadastral boundaries, areas and dimensions are approximate only. Written figured dimensions shall take preference to scaled dimensions.

CLIENT
New Day Church, Brisbane

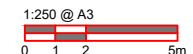

PROJECT NO. P0046052
DRAWING NO. 04
DATE 22/04/2026
REVISION -

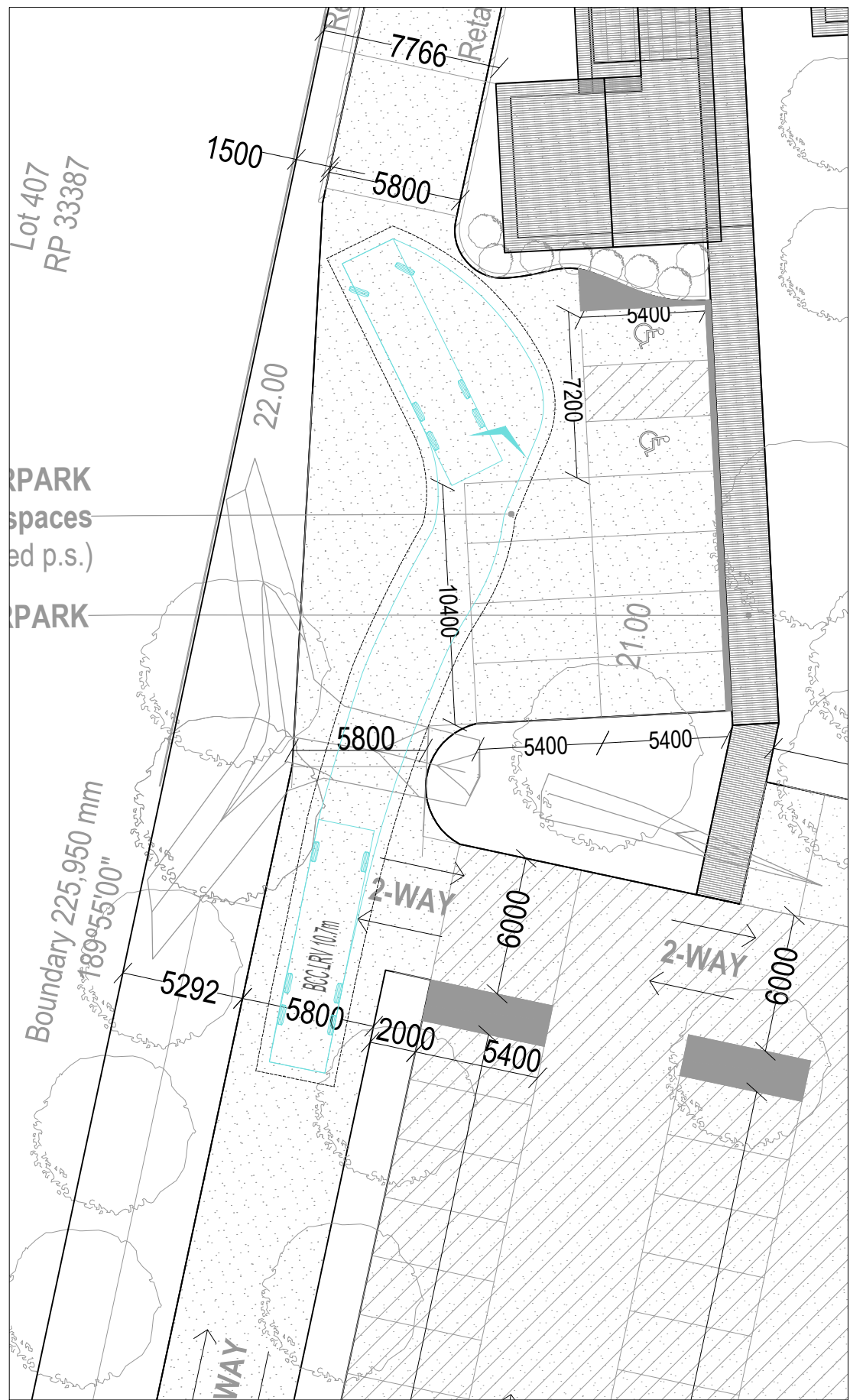

INGRESS

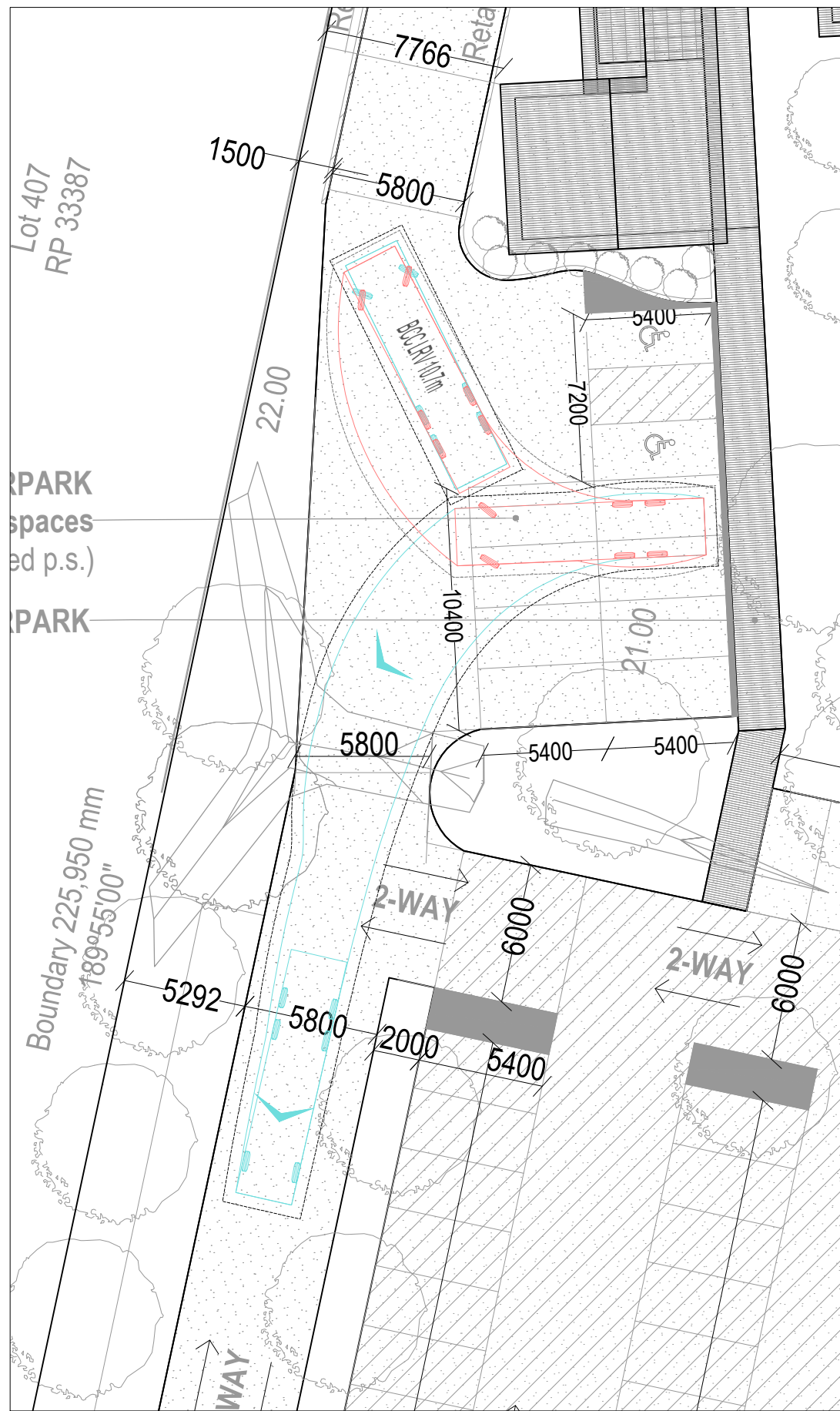

EGRESS

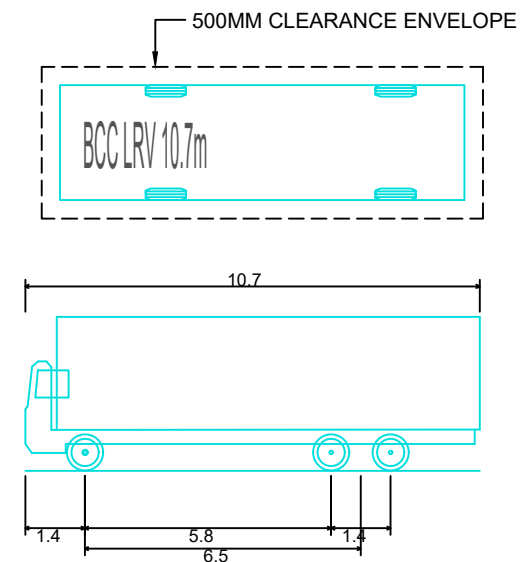

BCC LRV 10.7m	
Overall Length	10.700m
Overall Width	2.450m
Overall Body Height	3.623m
Min Body Ground Clearance	0.419m
Track Width	2.450m
Lock-to-lock time	4.00s
Curb to Curb Turning Radius	11.000m

**PRELIMINARY ADVICE ONLY
NOT FOR CONSTRUCTION
22/04/2026**

ALL DRAWINGS ARE DESIGNED TO BE PRINTED AND READ IN COLOUR
IT IS THE CONTRACTORS' RESPONSIBILITY TO PRINT DRAWINGS IN COLOUR TO AVOID ANY POTENTIAL DISCREPANCIES IF DRAWINGS ARE PRINTED IN BLACK AND WHITE



577 BOSTON ROAD, CHANDLER
LRV SWEEP PATHS - TURNAROUND

Level 32, 300 George Street | Brisbane QLD 4000 Australia | +61 7 3007 3800 | URBIS Pty Ltd | ABN 50 105 256 228

REV	DESCRIPTION	M.B.	A.T.	DWN	CHK	DATE
-	SWEPT PATHS					22/04/2026

DISCLAIMER
Copyright by Urbis Pty Ltd. This drawing or parts thereof may not be reproduced for any purpose or used for another project without the consent of Urbis. The plan must not be used for ordering, supply or installation and no reliance should be placed on this plan for any financial dealing of the land. This plan is conceptual and is for discussion purposes only and subject to further detail study. Council approval, engineering input, and survey. Cadastral boundaries, areas and dimensions are approximate only. Written figured dimensions shall take preference to scaled dimensions.

CLIENT
New Day Church, Brisbane

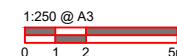

PROJECT NO. P0046052
DRAWING NO. 05
DATE 22/04/2026
REVISION -

Appendix C – Traffic Survey

Appendix D – SIDRA Results Summary

SITE LAYOUT

 Site: [1BG25] Tilley Rd/ Old Cleveland Rd_2025BG_Inbound
(2025 BG)

Tilley Rd/ Old Cleveland Rd
Site Category: (None)
Signals - EQUISAT (Fixed-Time/SCATS) Isolated
Site Scenario: 1 | Local Volumes

Layout pictures are schematic functional drawings reflecting input data. They are not design drawings.

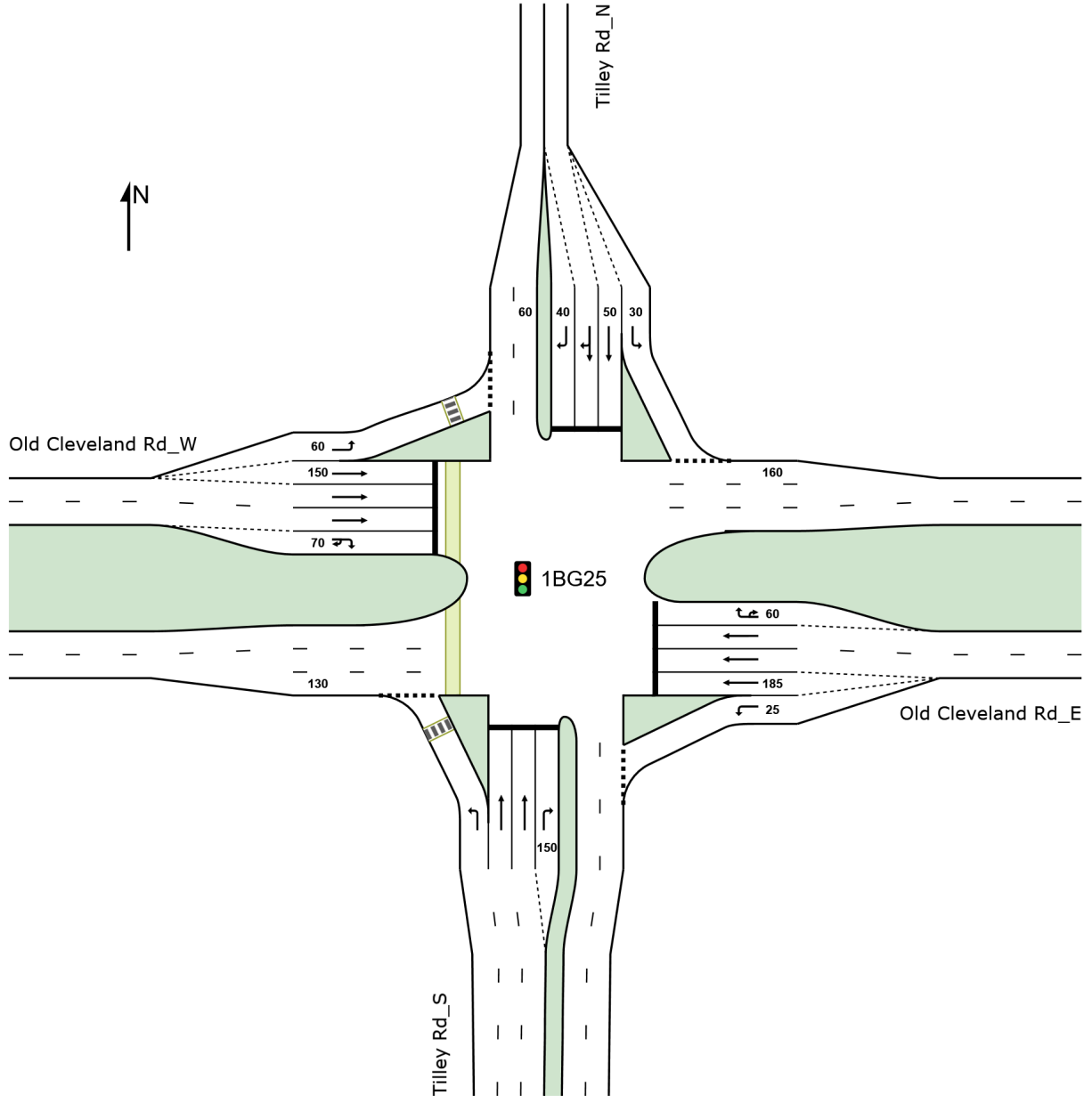

PHASING SUMMARY

 Site: [1BG25] Tilley Rd/ Old Cleveland Rd_2025BG_Inbound
(2025 BG)

Output produced by SIDRA INTERSECTION Version: 10.0.5.217

Tilley Rd/ Old Cleveland Rd

Site Category: (None)

Signals - EQUISAT (Fixed-Time/SCATS) Isolated Cycle Time = 140.0 seconds (Site User-Given Cycle Time)

Site Scenario: 1 | Local Volumes

Timings based on settings in the Site Phasing & Timing dialog

Phase Times determined by the program

Phase Sequence: Four-Phase Leading Right Turns

Input Phase Sequence: A, B, C, D, E

Output Phase Sequence: A, B, C, D, E

Reference Phase: Phase B

Phase Timing Summary

Phase	A	B	C	D	E
Phase Change Time (sec)	103.0	0.0	27.2	46.6	71.5
Green Time (sec)	31.0	21.2	13.4	18.9	25.5
Phase Time (sec)	37.0	27.2	19.4	24.9	31.5
Phase Split	26%	19%	14%	18%	22%
Phase Frequency (%)	100.0	100.0	100.0	100.0	100.0

See the Timing Analysis report for more detailed information including input values of Yellow Time and All-Red Time, and information on any adjustments to Intergreen Time, Phase Time and Green Time values in cases of Pedestrian Actuation, Minor Phase Actuation and Phase Frequency values (user-specified or implied) less than 100%.

Output Phase Sequence

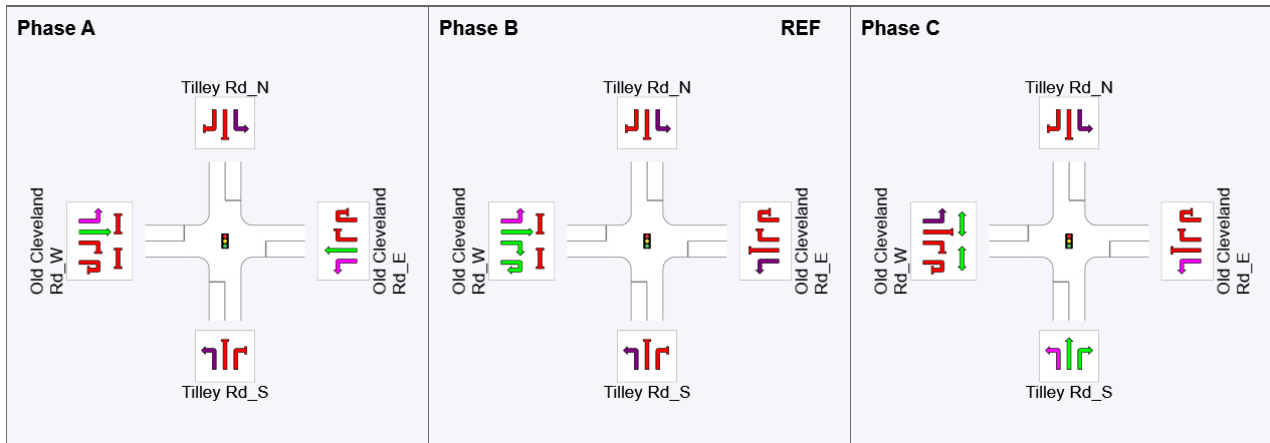

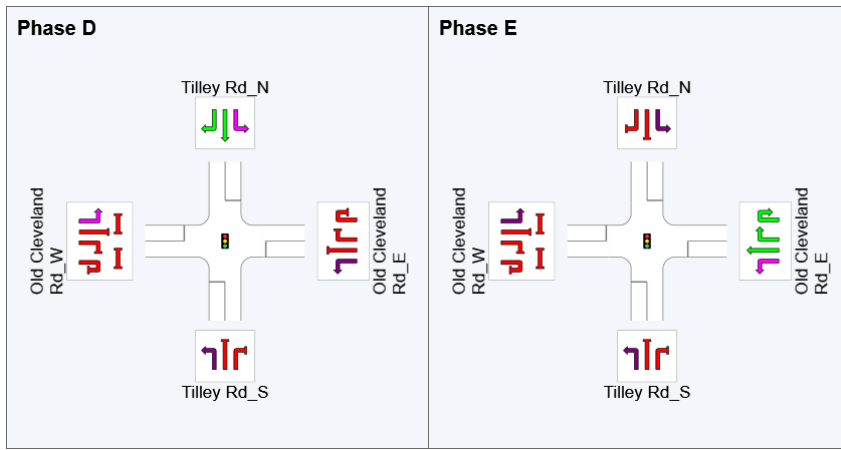

REF: Reference Phase
VAR: Variable Phase



SITE LAYOUT

▽ Site: [2BG25] Archer St/ Old Cleveland Rd_2025BG_Inbound
(2025 BG)

Archer St/ Old Cleveland Rd
Site Category: (None)
Give-Way (Two-Way)
Site Scenario: 1 | Local Volumes

Layout pictures are schematic functional drawings reflecting input data. They are not design drawings.

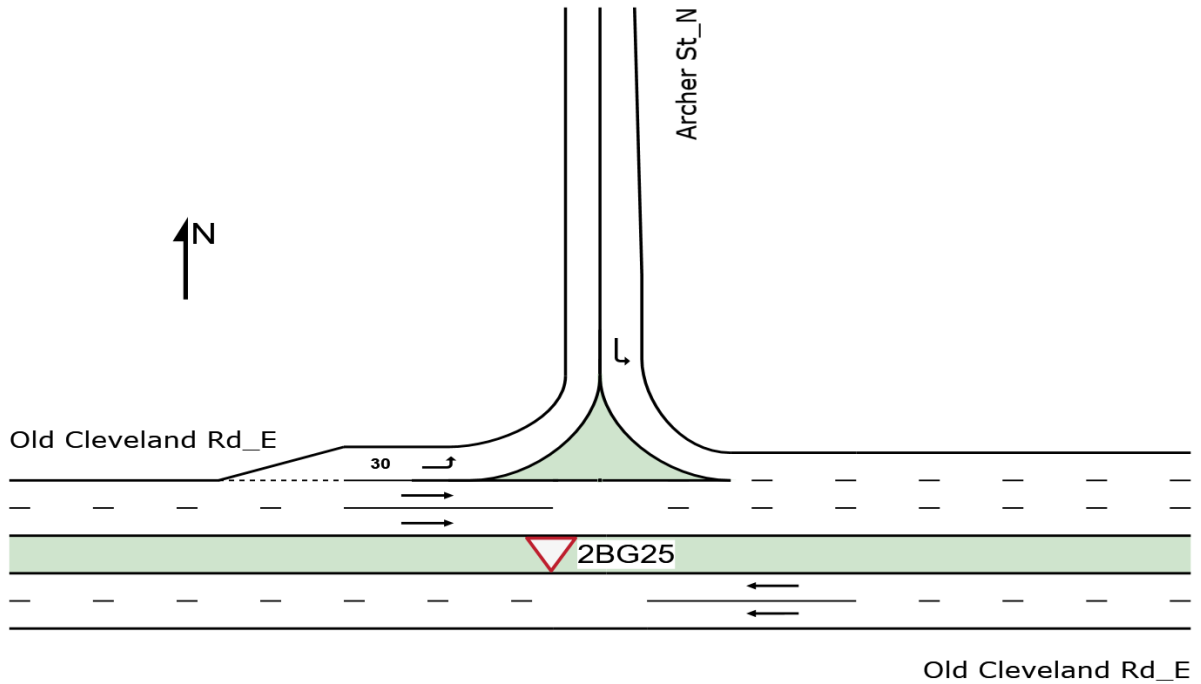

SITE LAYOUT

▽ Site: [3BG25] Tilley Rd/ Boston Rd_2025BG_Inbound (2025 BG)

Tilley Rd/ Boston Rd
Site Category: (None)
Give-Way (Two-Way)
Site Scenario: 1 | Local Volumes

Layout pictures are schematic functional drawings reflecting input data. They are not design drawings.

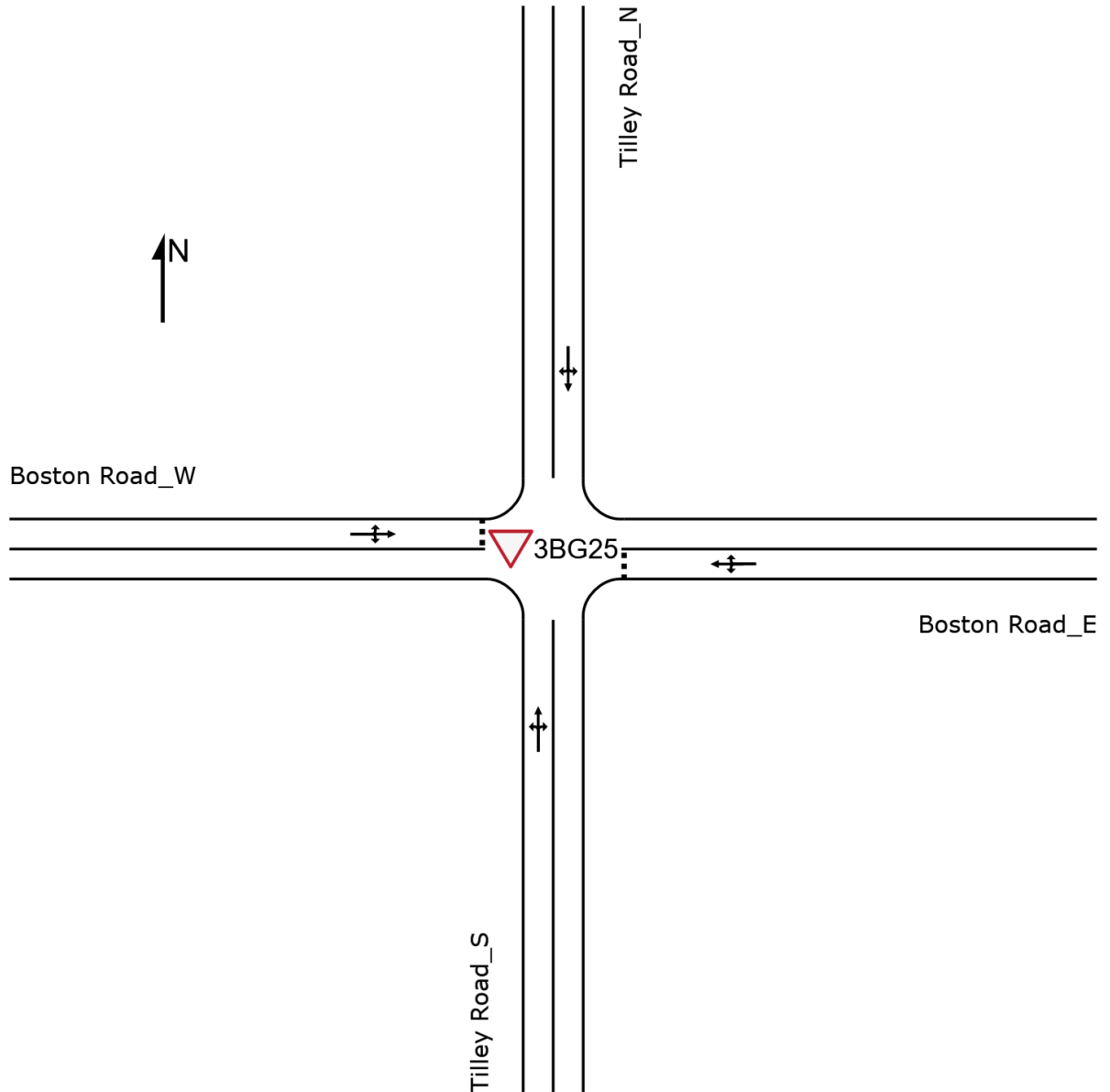

SITE LAYOUT

▽ Site: [4BG25] Boston Rd/ Archer St_2025BG_Inbound (2025 BG)

Boston Rd/ Archer St
Site Category: (None)
Give-Way (Two-Way)
Site Scenario: 1 | Local Volumes

Layout pictures are schematic functional drawings reflecting input data. They are not design drawings.

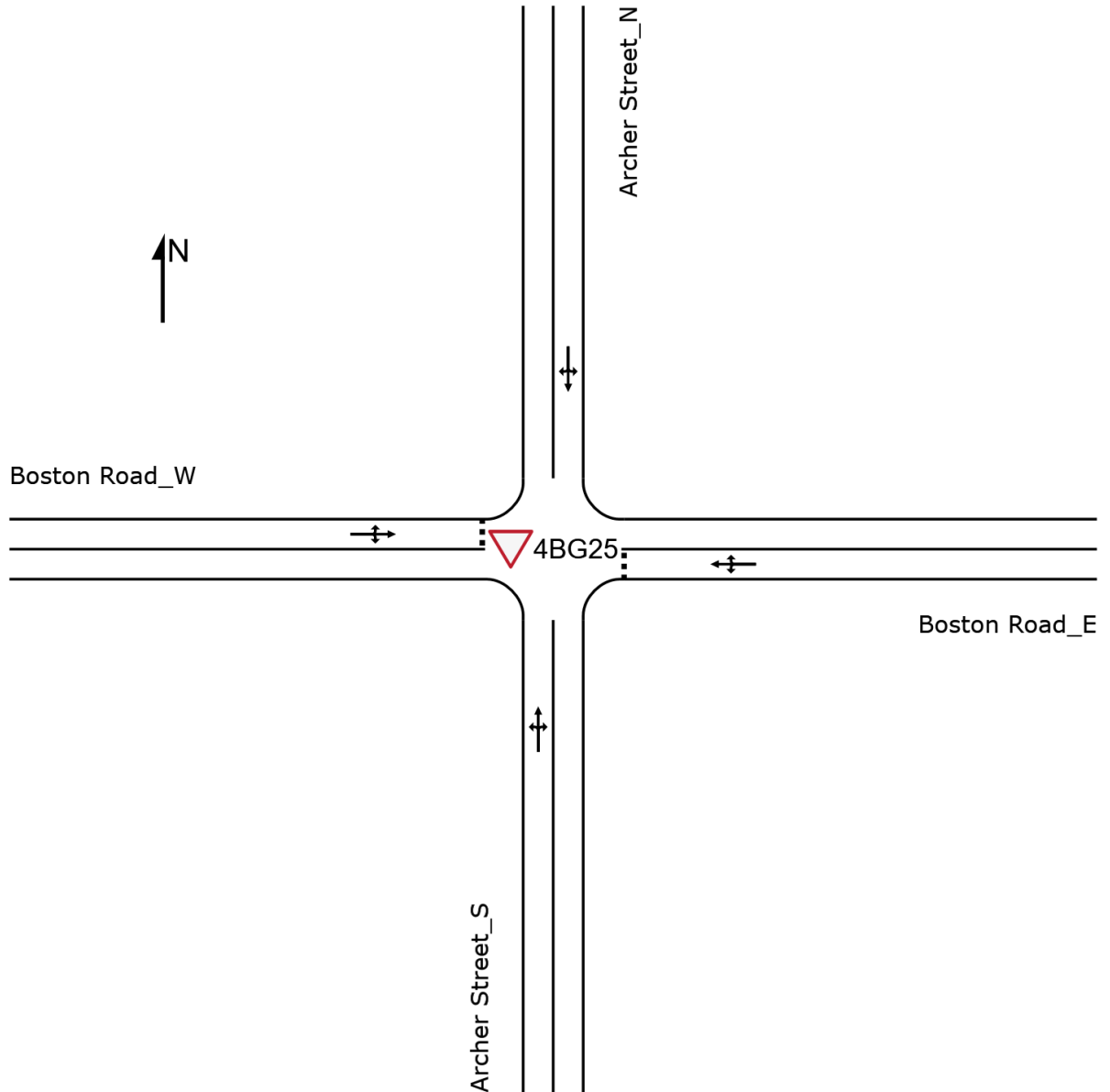

SITE LAYOUT

▽ Site: [5BG25] Boston Rd/ Site Access_2025BG_Inbound
(2025 BG)

Boston Rd/ Site Access
Site Category: (None)
Give-Way (Two-Way)
Site Scenario: 1 | Local Volumes

Layout pictures are schematic functional drawings reflecting input data. They are not design drawings.

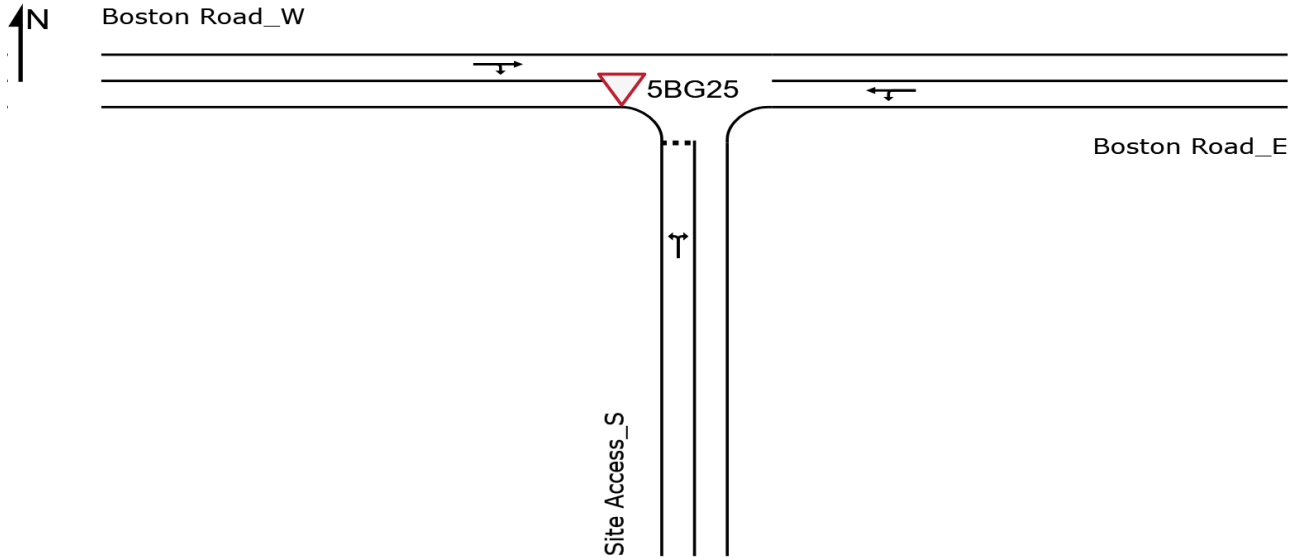

MOVEMENT SUMMARY

 Site: [1BG25] Tilley Rd/ Old Cleveland Rd_2025BG_Inbound (2025 BG)

Output produced by SIDRA INTERSECTION Version: 10.0.5.217

Tilley Rd/ Old Cleveland Rd

Site Category: (None)

Signals - EQUISAT (Fixed-Time/SCATS) Isolated Cycle Time = 140.0 seconds (Site User-Given Cycle Time)

Site Scenario: 1 | Local Volumes

Vehicle Movement Performance															
Mov ID	Turn	Mov Class	Demand Flows		Arrival Flows		Deg. Satn	Aver. Delay	Level of Service	95% Back Of Queue		Prop. Qued	Eff. Stop Rate	Number of Cycles to Depart	Aver. Speed
			[Total HV]	[Total HV]			v/c	sec							km/h
			veh/h	%	veh/h	%									
South: Tilley Rd_S															
1	L2	All MCs	121	1.0	121	1.0	0.071	8.7	LOS A	1.3	9.3	0.29	1.18	0.29	33.6
2	T1	All MCs	196	1.0	196	1.0	*0.715	68.4	LOS E	9.3	65.4	0.99	0.82	1.05	21.5
3	R2	All MCs	81	1.0	81	1.0	0.458	72.1	LOS E	5.4	38.2	0.99	0.77	0.99	23.0
Approach			398	1.0	398	1.0	0.715	51.0	LOS D	9.3	65.4	0.78	0.92	0.81	24.3
East: Old Cleveland Rd_E															
4	L2	All MCs	52	1.0	52	1.0	0.039	27.0	LOS C	0.5	3.4	0.24	1.07	0.24	36.9
5	T1	All MCs	1559	1.0	1559	1.0	*0.715	43.1	LOS D	33.9	239.1	0.85	0.76	0.85	40.8
6	R2	All MCs	99	1.0	99	1.0	0.324	76.5	LOS E	6.4	44.9	0.91	0.78	0.91	29.4
6u	U	All MCs	7	1.0	7	1.0	0.324	77.3	LOS E	6.4	44.9	0.91	0.78	0.91	30.7
Approach			1717	1.0	1717	1.0	0.715	44.7	LOS D	33.9	239.1	0.84	0.77	0.84	35.0
North: Tilley Rd_N															
7	L2	All MCs	43	1.0	43	1.0	0.055	19.3	LOS B	0.8	5.9	0.34	1.01	0.34	40.9
8	T1	All MCs	146	1.0	146	1.0	*0.711	74.3	LOS E	11.3	79.6	1.00	0.86	1.08	21.8
9	R2	All MCs	319	1.0	319	1.0	0.711	74.8	LOS E	11.3	79.6	1.00	0.85	1.06	24.2
Approach			508	1.0	508	1.0	0.711	70.0	LOS E	11.3	79.6	0.94	0.87	1.01	23.5
West: Old Cleveland Rd_W															
10	L2	All MCs	352	1.0	352	1.0	0.254	16.6	LOS B	1.7	11.8	0.13	0.82	0.13	44.8
11	T1	All MCs	1474	1.0	1474	1.0	0.710	42.6	LOS D	32.0	226.0	0.88	0.79	0.88	39.2
12	R2	All MCs	173	1.0	173	1.0	*0.715	81.9	LOS F	13.0	91.7	1.00	0.85	1.05	20.3
12u	U	All MCs	20	1.0	20	1.0	0.715	82.8	LOS F	13.0	91.7	1.00	0.85	1.05	23.6
Approach			2018	1.0	2018	1.0	0.715	41.9	LOS D	32.0	226.0	0.76	0.80	0.77	34.3
All Vehicles			4641	1.0	4641	1.0	0.715	46.8	LOS D	33.9	239.1	0.81	0.81	0.82	32.2

Site Level of Service (LOS) Method: Delay (SIDRA). Site LOS Method is specified in the Parameter Settings dialog (Options tab).

Vehicle movement LOS values are based on average delay per movement.

Intersection and Approach LOS values are based on average delay for all vehicle movements.

Delay Model: SIDRA Standard (Control Delay; Geometric Delay is included).

Queue Model: SIDRA queue estimation methods are used for Back of Queue and Queue at Start of Green.

Gap-Acceptance Capacity Formula: SIDRA Standard (Akçelik M3D).

HV (%) values are calculated for All Movement Classes of All Heavy Vehicle Model Designation.

Arrival Flows used in performance calculations are adjusted to include any Initial Queued Demand and Upstream Capacity Constraint effects.

* Critical Movement (Signal Timing)

Pedestrian Movement Performance											
Mov ID	Crossing	Input Vol.	Dem. Flow	Aver. Delay	Level of Service	AVERAGE BACK OF QUEUE	Prop. Qued	Eff. Stop	Travel Time	Travel Dist.	Aver. Speed

	ped/h	ped/h	sec		[Ped ped	Dist] m		Rate		sec	m	m/sec
West: Old Cleveland Rd_W												
P41 Stage 1	2	2	64.1	LOS F	0.0	0.0		0.96	0.96	218.0	200.0	0.92
P42 Stage 2	2	2	64.1	LOS F	0.0	0.0		0.96	0.96	218.0	200.0	0.92
All Pedestrians	4	4	64.1	LOS F	0.0	0.0		0.96	0.96	218.0	200.0	0.92

Level of Service (LOS) Method: SIDRA Pedestrian LOS Method (Based on Average Delay)

Pedestrian movement LOS values are based on average delay per pedestrian movement.

Intersection LOS value for Pedestrians is based on average delay for all pedestrian movements.

SIDRA INTERSECTION 10.0 | Copyright © 2000-2025 Akcelik and Associates Pty Ltd | sidrasolutions.com

Organisation: URBIS | Licence: NETWORK / 1PC | Processed: Tuesday, 3 February 2026 5:00:09 PM

Project: C:\Users\bchui\OneDrive - Urbis Ltd\P0046052 577 Boston Road Chandler - General\09_Transport\01_Analysis\P0046052_Boston Rd_SIDRA_260106.sipx

MOVEMENT SUMMARY

Site: [2BG25] Archer St/ Old Cleveland Rd_2025BG_Inbound
(2025 BG)

Output produced by SIDRA INTERSECTION Version: 10.0.5.217

Archer St/ Old Cleveland Rd
Site Category: (None)
Give-Way (Two-Way)
Site Scenario: 1 | Local Volumes

Vehicle Movement Performance															
Mov ID	Turn	Mov Class	Demand Flows	Arrival Flows	Deg. Satn	Aver. Delay	Level of Service	95% Back Of Queue	Prop. Qued	Eff. Stop Rate	Number of Cycles to Depart	Aver. Speed			
			[Total HV]	[Total HV]	v/c	sec		[Veh.]	[Dist]			km/h			
			veh/h	%	veh/h	%		veh	m						
East: Old Cleveland Rd_E															
5	T1	All MCs	1651	1.0	1651	1.0	0.426	0.1	LOSA	0.0	0.0	0.00	0.00	0.00	69.7
Approach			1651	1.0	1651	1.0	0.426	0.1	NA	0.0	0.0	0.00	0.00	0.00	69.7
North: Archer St_N															
7	L2	All MCs	73	1.0	73	1.0	0.039	5.0	LOSA	0.0	0.0	0.00	0.52	0.00	50.3
Approach			73	1.0	73	1.0	0.039	5.0	NA	0.0	0.0	0.00	0.52	0.00	50.3
West: Old Cleveland Rd_E															
10	L2	All MCs	41	1.0	41	1.0	0.022	6.7	LOSA	0.0	0.0	0.00	0.57	0.00	54.0
11	T1	All MCs	1493	1.0	1493	1.0	0.385	0.1	LOSA	0.0	0.0	0.00	0.00	0.00	69.7
Approach			1534	1.0	1534	1.0	0.385	0.3	NA	0.0	0.0	0.00	0.02	0.00	69.4
All Vehicles			3257	1.0	3257	1.0	0.426	0.3	NA	0.0	0.0	0.00	0.02	0.00	69.2

Site Level of Service (LOS) Method: Delay (SIDRA). Site LOS Method is specified in the Parameter Settings dialog (Options tab).
 Vehicle movement LOS values are based on average delay per movement.
 Minor Road Approach LOS values are based on average delay for all vehicle movements.
 NA (TWSC): Level of Service is not defined for major road approaches or the intersection as a whole for Two-Way Sign Control (HCM LOS rule).
 Two-Way Sign Control Capacity Model: SIDRA Standard.
 Delay Model: SIDRA Standard (Control Delay: Geometric Delay is included).
 Queue Model: SIDRA queue estimation methods are used for Back of Queue and Queue at Start of Gap.
 Gap-Acceptance Capacity Formula: SIDRA Standard (Akçelik M3D).
 HV (%) values are calculated for All Movement Classes of All Heavy Vehicle Model Designation.
 Arrival Flows used in performance calculations are adjusted to include any Initial Queued Demand and Upstream Capacity Constraint effects.

MOVEMENT SUMMARY

Site: [3BG25] Tilley Rd/ Boston Rd_2025BG_Inbound (2025 BG)

Output produced by SIDRA INTERSECTION Version: 10.0.5.217

Tilley Rd/ Boston Rd
 Site Category: (None)
 Give-Way (Two-Way)
 Site Scenario: 1 | Local Volumes

Vehicle Movement Performance															
Mov ID	Turn	Mov Class	Demand Flows		Arrival Flows		Deg. Satn	Aver. Delay	Level of Service	95% Back Of Queue		Prop. Qued	Eff. Stop Rate	Number of Cycles to Depart	Aver. Speed
			[Total HV]	%	[Total HV]	%	v/c	sec		[Veh.]	[Dist]				km/h
			veh/h		veh/h					veh	m				
South: Tilley Road_S															
1	L2	All MCs	14	1.0	14	1.0	0.345	8.0	LOS A	0.2	1.4	0.04	0.06	0.04	60.4
2	T1	All MCs	624	1.0	624	1.0	0.345	0.1	LOS A	0.2	1.4	0.04	0.06	0.04	69.2
3	R2	All MCs	16	1.0	16	1.0	0.345	8.6	LOS A	0.2	1.4	0.04	0.06	0.04	60.0
Approach			654	1.0	654	1.0	0.345	0.5	NA	0.2	1.4	0.04	0.06	0.04	68.7
East: Boston Road_E															
4	L2	All MCs	25	1.0	25	1.0	0.047	7.4	LOS A	0.2	1.1	0.55	0.70	0.55	51.3
5	T1	All MCs	3	1.0	3	1.0	0.047	13.7	LOS B	0.2	1.1	0.55	0.70	0.55	50.7
6	R2	All MCs	3	1.0	3	1.0	0.047	17.5	LOS C	0.2	1.1	0.55	0.70	0.55	51.3
Approach			32	1.0	32	1.0	0.047	9.0	LOS A	0.2	1.1	0.55	0.70	0.55	51.2
North: Tilley Road_N															
7	L2	All MCs	5	1.0	5	1.0	0.259	8.8	LOS A	0.1	0.8	0.03	0.04	0.03	60.7
8	T1	All MCs	483	1.0	483	1.0	0.259	0.1	LOS A	0.1	0.8	0.03	0.04	0.03	69.5
9	R2	All MCs	6	1.0	6	1.0	0.259	9.5	LOS A	0.1	0.8	0.03	0.04	0.03	60.3
Approach			495	1.0	495	1.0	0.259	0.3	NA	0.1	0.8	0.03	0.04	0.03	69.2
West: Boston Road_W															
10	L2	All MCs	1	1.0	1	1.0	0.082	8.2	LOS A	0.3	1.8	0.76	0.90	0.76	47.2
11	T1	All MCs	15	1.0	15	1.0	0.082	13.6	LOS B	0.3	1.8	0.76	0.90	0.76	46.8
12	R2	All MCs	9	1.0	9	1.0	0.082	17.9	LOS C	0.3	1.8	0.76	0.90	0.76	46.8
Approach			25	1.0	25	1.0	0.082	15.0	LOS B	0.3	1.8	0.76	0.90	0.76	46.8
All Vehicles			1205	1.0	1205	1.0	0.345	0.9	NA	0.3	1.8	0.06	0.09	0.06	67.5

Site Level of Service (LOS) Method: Delay (SIDRA). Site LOS Method is specified in the Parameter Settings dialog (Options tab).
 Vehicle movement LOS values are based on average delay per movement.
 Minor Road Approach LOS values are based on average delay for all vehicle movements.
 NA (TWSC): Level of Service is not defined for major road approaches or the intersection as a whole for Two-Way Sign Control (HCM LOS rule).
 Two-Way Sign Control Capacity Model: SIDRA Standard.
 Delay Model: SIDRA Standard (Control Delay: Geometric Delay is included).
 Queue Model: SIDRA queue estimation methods are used for Back of Queue and Queue at Start of Gap.
 Gap-Acceptance Capacity Formula: SIDRA Standard (Akçelik M3D).
 HV (%) values are calculated for All Movement Classes of All Heavy Vehicle Model Designation.
 Arrival Flows used in performance calculations are adjusted to include any Initial Queued Demand and Upstream Capacity Constraint effects.

MOVEMENT SUMMARY

Site: [4BG25] Boston Rd/ Archer St_2025BG_Inbound (2025 BG)

Output produced by SIDRA INTERSECTION Version: 10.0.5.217

Boston Rd/ Archer St
 Site Category: (None)
 Give-Way (Two-Way)
 Site Scenario: 1 | Local Volumes

Vehicle Movement Performance															
Mov ID	Turn	Mov Class	Demand Flows		Arrival Flows		Deg. Satn	Aver. Delay	Level of Service	95% Back Of Queue		Prop. Qued	Eff. Stop of Cycles	Number of Cycles	Aver. Speed
			[Total HV]	[Total HV]			v/c	sec	[Veh. Dist]				Rate to Depart	km/h	
			veh/h	%	veh/h	%									
South: Archer Street_S															
1	L2	All MCs	1	1.0	1	1.0	0.024	5.2	LOS A	0.0	0.3	0.07	0.11	0.07	54.2
2	T1	All MCs	38	1.0	38	1.0	0.024	0.1	LOS A	0.0	0.3	0.07	0.11	0.07	57.9
3	R2	All MCs	6	1.0	6	1.0	0.024	5.1	LOS A	0.0	0.3	0.07	0.11	0.07	53.7
Approach			45	1.0	45	1.0	0.024	0.9	NA	0.0	0.3	0.07	0.11	0.07	57.1
East: Boston Road_E															
4	L2	All MCs	1	1.0	1	1.0	0.022	5.8	LOS A	0.1	0.5	0.23	0.54	0.23	48.7
5	T1	All MCs	14	1.0	14	1.0	0.022	4.7	LOS A	0.1	0.5	0.23	0.54	0.23	53.2
6	R2	All MCs	9	1.0	9	1.0	0.022	6.2	LOS A	0.1	0.5	0.23	0.54	0.23	51.8
Approach			24	1.0	24	1.0	0.022	5.3	LOS A	0.1	0.5	0.23	0.54	0.23	52.6
North: Archer Street_N															
7	L2	All MCs	16	1.0	16	1.0	0.055	5.6	LOS A	0.1	0.6	0.04	0.16	0.04	55.6
8	T1	All MCs	77	1.0	77	1.0	0.055	0.0	LOS A	0.1	0.6	0.04	0.16	0.04	56.9
9	R2	All MCs	12	1.0	12	1.0	0.055	5.5	LOS A	0.1	0.6	0.04	0.16	0.04	55.3
Approach			104	1.0	104	1.0	0.055	1.5	NA	0.1	0.6	0.04	0.16	0.04	56.3
West: Boston Road_W															
10	L2	All MCs	7	1.0	7	1.0	0.024	5.7	LOS A	0.1	0.6	0.18	0.54	0.18	52.0
11	T1	All MCs	9	1.0	9	1.0	0.024	4.7	LOS A	0.1	0.6	0.18	0.54	0.18	53.2
12	R2	All MCs	11	1.0	11	1.0	0.024	6.1	LOS A	0.1	0.6	0.18	0.54	0.18	48.1
Approach			27	1.0	27	1.0	0.024	5.5	LOS A	0.1	0.6	0.18	0.54	0.18	51.4
All Vehicles			201	1.0	201	1.0	0.055	2.3	NA	0.1	0.6	0.09	0.25	0.09	54.8

Site Level of Service (LOS) Method: Delay (SIDRA). Site LOS Method is specified in the Parameter Settings dialog (Options tab).
 Vehicle movement LOS values are based on average delay per movement.
 Minor Road Approach LOS values are based on average delay for all vehicle movements.
 NA (TWSC): Level of Service is not defined for major road approaches or the intersection as a whole for Two-Way Sign Control (HCM LOS rule).
 Two-Way Sign Control Capacity Model: SIDRA Standard.
 Delay Model: SIDRA Standard (Control Delay: Geometric Delay is included).
 Queue Model: SIDRA queue estimation methods are used for Back of Queue and Queue at Start of Gap.
 Gap-Acceptance Capacity Formula: SIDRA Standard (Akçelik M3D).
 HV (%) values are calculated for All Movement Classes of All Heavy Vehicle Model Designation.
 Arrival Flows used in performance calculations are adjusted to include any Initial Queued Demand and Upstream Capacity Constraint effects.

MOVEMENT SUMMARY

Site: [5BG25] Boston Rd/ Site Access_2025BG_Inbound
(2025 BG)

Output produced by SIDRA INTERSECTION Version: 10.0.5.217

Boston Rd/ Site Access
Site Category: (None)
Give-Way (Two-Way)
Site Scenario: 1 | Local Volumes

Vehicle Movement Performance															
Mov ID	Turn	Mov Class	Demand Flows		Arrival Flows		Deg. Satn	Aver. Delay	Level of Service	95% Back Of Queue		Prop. Qued	Eff. Stop of Cycles	Number of Cycles to Depart	Aver. Speed
			[Total HV]	[Total HV]	[Total HV]	[Total HV]	v/c	sec		[Veh.]	[Dist]		Rate		km/h
			veh/h	%	veh/h	%				veh	m				
South: Site Access_S															
1	L2	All MCs	1	1.0	1	1.0	0.002	1.9	LOS A	0.0	0.0	0.10	0.41	0.10	51.2
3	R2	All MCs	1	1.0	1	1.0	0.002	1.9	LOS A	0.0	0.0	0.10	0.41	0.10	50.7
Approach			2	1.0	2	1.0	0.002	1.9	LOS A	0.0	0.0	0.10	0.41	0.10	50.9
East: Boston Road_E															
4	L2	All MCs	1	1.0	1	1.0	0.015	5.6	LOS A	0.0	0.0	0.00	0.02	0.00	57.9
5	T1	All MCs	27	1.0	27	1.0	0.015	0.0	LOS A	0.0	0.0	0.00	0.02	0.00	59.8
Approach			28	1.0	28	1.0	0.015	0.2	NA	0.0	0.0	0.00	0.02	0.00	59.8
West: Boston Road_W															
11	T1	All MCs	37	1.0	37	1.0	0.020	0.0	LOS A	0.0	0.0	0.01	0.02	0.01	59.8
12	R2	All MCs	1	1.0	1	1.0	0.020	5.5	LOS A	0.0	0.0	0.01	0.02	0.01	57.6
Approach			38	1.0	38	1.0	0.020	0.2	NA	0.0	0.0	0.01	0.02	0.01	59.8
All Vehicles			68	1.0	68	1.0	0.020	0.2	NA	0.0	0.0	0.01	0.03	0.01	59.6

Site Level of Service (LOS) Method: Delay (SIDRA). Site LOS Method is specified in the Parameter Settings dialog (Options tab).
 Vehicle movement LOS values are based on average delay per movement.
 Minor Road Approach LOS values are based on average delay for all vehicle movements.
 NA (TWSC): Level of Service is not defined for major road approaches or the intersection as a whole for Two-Way Sign Control (HCM LOS rule).
 Two-Way Sign Control Capacity Model: SIDRA Standard.
 Delay Model: SIDRA Standard (Control Delay: Geometric Delay is included).
 Queue Model: SIDRA queue estimation methods are used for Back of Queue and Queue at Start of Gap.
 Gap-Acceptance Capacity Formula: SIDRA Standard (Akçelik M3D).
 HV (%) values are calculated for All Movement Classes of All Heavy Vehicle Model Designation.
 Arrival Flows used in performance calculations are adjusted to include any Initial Queued Demand and Upstream Capacity Constraint effects.

MOVEMENT SUMMARY

 Site: [1BG27I] Tilley Rd/ Old Cleveland Rd_2027BG_Inbound
(2027 BG Inbound)

Output produced by SIDRA INTERSECTION Version: 10.0.5.217

Tilley Rd/ Old Cleveland Rd

Site Category: (None)

Signals - EQUISAT (Fixed-Time/SCATS) Isolated Cycle Time = 140.0 seconds (Site User-Given Cycle Time)

Site Scenario: 1 | Local Volumes

Vehicle Movement Performance															
Mov ID	Turn	Mov Class	Demand Flows		Arrival Flows		Deg. Satn	Aver. Delay	Level of Service	95% Back Of Queue		Prop. Qued	Eff. Stop Rate	Number of Cycles to Depart	Aver. Speed
			[Total HV]	[Total HV]	[Total HV]	[Total HV]	v/c	sec		[Veh.]	[Dist]				km/h
			veh/h	%	veh/h	%				veh	m				
South: Tilley Rd_S															
1	L2	All MCs	122	1.0	122	1.0	0.072	8.7	LOS A	1.3	9.3	0.29	1.18	0.29	33.6
2	T1	All MCs	198	1.0	198	1.0	*0.725	68.7	LOS E	9.4	66.3	0.99	0.82	1.06	21.4
3	R2	All MCs	82	1.0	82	1.0	0.466	72.2	LOS E	5.5	38.7	0.99	0.77	0.99	22.9
Approach			402	1.0	402	1.0	0.725	51.2	LOS D	9.4	66.3	0.78	0.92	0.81	24.2
East: Old Cleveland Rd_E															
4	L2	All MCs	52	1.0	52	1.0	0.039	27.2	LOS C	0.5	3.4	0.24	1.08	0.24	36.8
5	T1	All MCs	1575	1.0	1575	1.0	*0.725	43.4	LOS D	34.5	243.8	0.86	0.77	0.86	40.6
6	R2	All MCs	106	1.0	106	1.0	0.346	77.1	LOS E	6.8	48.3	0.92	0.78	0.92	29.3
6u	U	All MCs	7	1.0	7	1.0	0.346	77.8	LOS E	6.8	48.3	0.92	0.78	0.92	30.7
Approach			1740	1.0	1740	1.0	0.725	45.2	LOS D	34.5	243.8	0.85	0.78	0.85	34.8
North: Tilley Rd_N															
7	L2	All MCs	43	1.0	43	1.0	0.056	20.0	LOS B	0.9	6.1	0.35	1.04	0.35	40.1
8	T1	All MCs	147	1.0	147	1.0	*0.720	74.9	LOS E	11.4	80.7	1.00	0.86	1.09	21.7
9	R2	All MCs	322	1.0	322	1.0	0.720	75.6	LOS E	11.4	80.7	1.00	0.86	1.07	24.2
Approach			513	1.0	513	1.0	0.720	70.7	LOS E	11.4	80.7	0.95	0.88	1.02	23.3
West: Old Cleveland Rd_W															
10	L2	All MCs	368	1.0	368	1.0	0.268	16.8	LOS B	1.7	12.3	0.13	0.82	0.13	44.8
11	T1	All MCs	1488	1.0	1488	1.0	0.722	43.1	LOS D	32.7	231.2	0.89	0.79	0.89	39.0
12	R2	All MCs	175	1.0	175	1.0	*0.725	82.7	LOS F	13.2	93.1	1.00	0.86	1.06	20.2
12u	U	All MCs	20	1.0	20	1.0	0.725	83.6	LOS F	13.2	93.1	1.00	0.86	1.06	23.5
Approach			2052	1.0	2052	1.0	0.725	42.2	LOS D	32.7	231.2	0.77	0.80	0.77	34.2
All Vehicles			4706	1.0	4706	1.0	0.725	47.2	LOS D	34.5	243.8	0.82	0.81	0.83	32.0

Site Level of Service (LOS) Method: Delay (SIDRA). Site LOS Method is specified in the Parameter Settings dialog (Options tab).

Vehicle movement LOS values are based on average delay per movement.

Intersection and Approach LOS values are based on average delay for all vehicle movements.

Delay Model: SIDRA Standard (Control Delay; Geometric Delay is included).

Queue Model: SIDRA queue estimation methods are used for Back of Queue and Queue at Start of Green.

Gap-Acceptance Capacity Formula: SIDRA Standard (Akçelik M3D).

HV (%) values are calculated for All Movement Classes of All Heavy Vehicle Model Designation.

Arrival Flows used in performance calculations are adjusted to include any Initial Queued Demand and Upstream Capacity Constraint effects.

* Critical Movement (Signal Timing)

Pedestrian Movement Performance											
Mov ID	Crossing	Input Vol.	Dem. Flow	Aver. Delay	Level of Service	AVERAGE BACK OF QUEUE	Prop. Qued	Eff. Stop	Travel Time	Travel Dist.	Aver. Speed

	ped/h	ped/h	sec		[Ped ped	Dist] m		Rate		sec	m	m/sec
West: Old Cleveland Rd_W												
P41 Stage 1	2	2	64.1	LOS F	0.0	0.0		0.96	0.96	218.0	200.0	0.92
P42 Stage 2	2	2	64.1	LOS F	0.0	0.0		0.96	0.96	218.0	200.0	0.92
All Pedestrians	4	4	64.1	LOS F	0.0	0.0		0.96	0.96	218.0	200.0	0.92

Level of Service (LOS) Method: SIDRA Pedestrian LOS Method (Based on Average Delay)

Pedestrian movement LOS values are based on average delay per pedestrian movement.

Intersection LOS value for Pedestrians is based on average delay for all pedestrian movements.

SIDRA INTERSECTION 10.0 | Copyright © 2000-2025 Akcelik and Associates Pty Ltd | sidrasolutions.com

Organisation: URBIS | Licence: NETWORK / 1PC | Processed: Tuesday, 3 February 2026 5:00:11 PM

Project: C:\Users\bchui\OneDrive - Urbis Ltd\P0046052 577 Boston Road Chandler - General\09_Transport\01_Analysis\P0046052_Boston Rd_SIDRA_260106.sipx

MOVEMENT SUMMARY

Site: [2BG27I] Archer St/ Old Cleveland Rd_2027BG_Inbound
(2027 BG Inbound)

Output produced by SIDRA INTERSECTION Version: 10.0.5.217

Archer St/ Old Cleveland Rd

Site Category: (None)

Give-Way (Two-Way)

Site Scenario: 1 | Local Volumes

Vehicle Movement Performance															
Mov ID	Turn	Mov Class	Demand Flows	Arrival Flows	Deg. Satn	Aver. Delay	Level of Service	95% Back Of Queue	Prop. Qued	Eff. Stop Rate	Number of Cycles to Depart	Aver. Speed			
			[Total HV]	[Total HV]	v/c	sec		[Veh. Dist]				km/h			
			veh/h	%	veh/h	%		veh	m						
East: Old Cleveland Rd_E															
5	T1	All MCs	1674	1.0	1674	1.0	0.432	0.1	LOSA	0.0	0.0	0.00	0.00	0.00	69.7
Approach			1674	1.0	1674	1.0	0.432	0.1	NA	0.0	0.0	0.00	0.00	0.00	69.7
North: Archer St_N															
7	L2	All MCs	74	1.0	74	1.0	0.040	5.0	LOSA	0.0	0.0	0.00	0.52	0.00	50.3
Approach			74	1.0	74	1.0	0.040	5.0	NA	0.0	0.0	0.00	0.52	0.00	50.3
West: Old Cleveland Rd_E															
10	L2	All MCs	41	1.0	41	1.0	0.022	6.7	LOSA	0.0	0.0	0.00	0.57	0.00	54.0
11	T1	All MCs	1507	1.0	1507	1.0	0.389	0.1	LOSA	0.0	0.0	0.00	0.00	0.00	69.7
Approach			1548	1.0	1548	1.0	0.389	0.3	NA	0.0	0.0	0.00	0.02	0.00	69.4
All Vehicles			3296	1.0	3296	1.0	0.432	0.3	NA	0.0	0.0	0.00	0.02	0.00	69.2

Site Level of Service (LOS) Method: Delay (SIDRA). Site LOS Method is specified in the Parameter Settings dialog (Options tab).

Vehicle movement LOS values are based on average delay per movement.

Minor Road Approach LOS values are based on average delay for all vehicle movements.

NA (TWSC): Level of Service is not defined for major road approaches or the intersection as a whole for Two-Way Sign Control (HCM LOS rule).

Two-Way Sign Control Capacity Model: SIDRA Standard.

Delay Model: SIDRA Standard (Control Delay: Geometric Delay is included).

Queue Model: SIDRA queue estimation methods are used for Back of Queue and Queue at Start of Gap.

Gap-Acceptance Capacity Formula: SIDRA Standard (Akçelik M3D).

HV (%) values are calculated for All Movement Classes of All Heavy Vehicle Model Designation.

Arrival Flows used in performance calculations are adjusted to include any Initial Queued Demand and Upstream Capacity Constraint effects.

SIDRA INTERSECTION 10.0 | Copyright © 2000-2025 Akcelik and Associates Pty Ltd | sidrasolutions.com

Organisation: URBIS | Licence: NETWORK / 1PC | Processed: Tuesday, 3 February 2026 5:00:11 PM

Project: C:\Users\bchui\OneDrive - Urbis Ltd\P0046052 577 Boston Road Chandler - General\09_Transport\01_Analysis\P0046052_Boston Rd_SIDRA_260106.sipx

MOVEMENT SUMMARY

Site: [3BG27I] Tilley Rd/ Boston Rd_2027BG_Inbound (2027 BG Inbound)

Output produced by SIDRA INTERSECTION Version: 10.0.5.217

Tilley Rd/ Boston Rd
 Site Category: (None)
 Give-Way (Two-Way)
 Site Scenario: 1 | Local Volumes

Vehicle Movement Performance															
Mov ID	Turn	Mov Class	Demand Flows		Arrival Flows		Deg. Satn	Aver. Delay	Level of Service	95% Back Of Queue		Prop. Qued	Eff. Stop Rate	Number of Cycles to Depart	Aver. Speed
			[Total HV]	[Total HV]	[Total HV]	[Total HV]	v/c	sec		[Veh.]	[Dist]				km/h
			veh/h	%	veh/h	%				veh	m				
South: Tilley Road_S															
1	L2	All MCs	14	1.0	14	1.0	0.368	8.6	LOS A	0.4	3.1	0.08	0.12	0.08	59.9
2	T1	All MCs	631	1.0	631	1.0	0.368	0.3	LOS A	0.4	3.1	0.08	0.12	0.08	68.6
3	R2	All MCs	37	1.0	37	1.0	0.368	8.8	LOS A	0.4	3.1	0.08	0.12	0.08	59.5
Approach			681	1.0	681	1.0	0.368	0.9	NA	0.4	3.1	0.08	0.12	0.08	67.7
East: Boston Road_E															
4	L2	All MCs	25	1.0	25	1.0	0.048	7.4	LOS A	0.2	1.2	0.56	0.71	0.56	51.2
5	T1	All MCs	3	1.0	3	1.0	0.048	14.5	LOS B	0.2	1.2	0.56	0.71	0.56	50.6
6	R2	All MCs	3	1.0	3	1.0	0.048	18.5	LOS C	0.2	1.2	0.56	0.71	0.56	51.2
Approach			32	1.0	32	1.0	0.048	9.2	LOS A	0.2	1.2	0.56	0.71	0.56	51.1
North: Tilley Road_N															
7	L2	All MCs	13	1.0	13	1.0	0.266	8.0	LOS A	0.1	0.8	0.03	0.05	0.03	60.6
8	T1	All MCs	488	1.0	488	1.0	0.266	0.1	LOS A	0.1	0.8	0.03	0.05	0.03	69.3
9	R2	All MCs	6	1.0	6	1.0	0.266	9.6	LOS A	0.1	0.8	0.03	0.05	0.03	60.2
Approach			507	1.0	507	1.0	0.266	0.4	NA	0.1	0.8	0.03	0.05	0.03	68.9
West: Boston Road_W															
10	L2	All MCs	1	1.0	1	1.0	0.087	8.3	LOS A	0.3	1.9	0.78	0.90	0.78	46.6
11	T1	All MCs	15	1.0	15	1.0	0.087	14.4	LOS B	0.3	1.9	0.78	0.90	0.78	46.3
12	R2	All MCs	9	1.0	9	1.0	0.087	18.8	LOS C	0.3	1.9	0.78	0.90	0.78	46.2
Approach			25	1.0	25	1.0	0.087	15.8	LOS C	0.3	1.9	0.78	0.90	0.78	46.3
All Vehicles			1245	1.0	1245	1.0	0.368	1.2	NA	0.4	3.1	0.09	0.12	0.09	66.9

Site Level of Service (LOS) Method: Delay (SIDRA). Site LOS Method is specified in the Parameter Settings dialog (Options tab).
 Vehicle movement LOS values are based on average delay per movement.
 Minor Road Approach LOS values are based on average delay for all vehicle movements.
 NA (TWSC): Level of Service is not defined for major road approaches or the intersection as a whole for Two-Way Sign Control (HCM LOS rule).
 Two-Way Sign Control Capacity Model: SIDRA Standard.
 Delay Model: SIDRA Standard (Control Delay: Geometric Delay is included).
 Queue Model: SIDRA queue estimation methods are used for Back of Queue and Queue at Start of Gap.
 Gap-Acceptance Capacity Formula: SIDRA Standard (Akçelik M3D).
 HV (%) values are calculated for All Movement Classes of All Heavy Vehicle Model Designation.
 Arrival Flows used in performance calculations are adjusted to include any Initial Queued Demand and Upstream Capacity Constraint effects.

MOVEMENT SUMMARY

Site: [4BG27I] Boston Rd/ Archer St_2027BG_Inbound (2027 BG Inbound)

Output produced by SIDRA INTERSECTION Version: 10.0.5.217

Boston Rd/ Archer St
 Site Category: (None)
 Give-Way (Two-Way)
 Site Scenario: 1 | Local Volumes

Vehicle Movement Performance															
Mov ID	Turn	Mov Class	Demand Flows		Arrival Flows		Deg. Satn	Aver. Delay	Level of Service	95% Back Of Queue		Prop. Qued	Eff. Stop of Cycles	Number of Cycles	Aver. Speed
			[Total HV]	[Total HV]	[Total HV]	[Total HV]	v/c	sec		[Veh.]	[Dist]		Rate to Depart		km/h
			veh/h	%	veh/h	%				veh	m				
South: Archer Street_S															
1	L2	All MCs	1	1.0	1	1.0	0.024	5.2	LOS A	0.0	0.3	0.07	0.11	0.07	54.2
2	T1	All MCs	38	1.0	38	1.0	0.024	0.1	LOS A	0.0	0.3	0.07	0.11	0.07	57.9
3	R2	All MCs	6	1.0	6	1.0	0.024	5.1	LOS A	0.0	0.3	0.07	0.11	0.07	53.7
Approach			45	1.0	45	1.0	0.024	0.9	NA	0.0	0.3	0.07	0.11	0.07	57.1
East: Boston Road_E															
4	L2	All MCs	1	1.0	1	1.0	0.022	5.8	LOS A	0.1	0.5	0.23	0.54	0.23	48.7
5	T1	All MCs	14	1.0	14	1.0	0.022	4.7	LOS A	0.1	0.5	0.23	0.54	0.23	53.2
6	R2	All MCs	9	1.0	9	1.0	0.022	6.2	LOS A	0.1	0.5	0.23	0.54	0.23	51.8
Approach			24	1.0	24	1.0	0.022	5.3	LOS A	0.1	0.5	0.23	0.54	0.23	52.6
North: Archer Street_N															
7	L2	All MCs	16	1.0	16	1.0	0.056	5.6	LOS A	0.1	0.6	0.04	0.16	0.04	55.6
8	T1	All MCs	78	1.0	78	1.0	0.056	0.0	LOS A	0.1	0.6	0.04	0.16	0.04	56.9
9	R2	All MCs	12	1.0	12	1.0	0.056	5.5	LOS A	0.1	0.6	0.04	0.16	0.04	55.3
Approach			105	1.0	105	1.0	0.056	1.5	NA	0.1	0.6	0.04	0.16	0.04	56.3
West: Boston Road_W															
10	L2	All MCs	7	1.0	7	1.0	0.024	5.7	LOS A	0.1	0.6	0.18	0.54	0.18	52.0
11	T1	All MCs	9	1.0	9	1.0	0.024	4.7	LOS A	0.1	0.6	0.18	0.54	0.18	53.2
12	R2	All MCs	11	1.0	11	1.0	0.024	6.1	LOS A	0.1	0.6	0.18	0.54	0.18	48.1
Approach			27	1.0	27	1.0	0.024	5.5	LOS A	0.1	0.6	0.18	0.54	0.18	51.4
All Vehicles			202	1.0	202	1.0	0.056	2.3	NA	0.1	0.6	0.09	0.24	0.09	54.9

Site Level of Service (LOS) Method: Delay (SIDRA). Site LOS Method is specified in the Parameter Settings dialog (Options tab).
 Vehicle movement LOS values are based on average delay per movement.
 Minor Road Approach LOS values are based on average delay for all vehicle movements.
 NA (TWSC): Level of Service is not defined for major road approaches or the intersection as a whole for Two-Way Sign Control (HCM LOS rule).
 Two-Way Sign Control Capacity Model: SIDRA Standard.
 Delay Model: SIDRA Standard (Control Delay: Geometric Delay is included).
 Queue Model: SIDRA queue estimation methods are used for Back of Queue and Queue at Start of Gap.
 Gap-Acceptance Capacity Formula: SIDRA Standard (Akçelik M3D).
 HV (%) values are calculated for All Movement Classes of All Heavy Vehicle Model Designation.
 Arrival Flows used in performance calculations are adjusted to include any Initial Queued Demand and Upstream Capacity Constraint effects.

MOVEMENT SUMMARY

Site: [5BG27I] Boston Rd/ Site Access_2027BG_Inbound
(2027 BG Inbound)

Output produced by SIDRA INTERSECTION Version: 10.0.5.217

Boston Rd/ Site Access

Site Category: (None)

Give-Way (Two-Way)

Site Scenario: 1 | Local Volumes

Vehicle Movement Performance															
Mov ID	Turn	Mov Class	Demand Flows		Arrival Flows		Deg. Satn	Aver. Delay	Level of Service	95% Back Of Queue		Prop. Qued	Eff. Stop of Cycles	Number of Cycles	Aver. Speed
			[Total HV]	[Total HV]	[Total HV]	[Total HV]	v/c	sec		[Veh.]	[Dist]		Rate to Depart		km/h
			veh/h	%	veh/h	%				veh	m				
South: Site Access_S															
1	L2	All MCs	1	1.0	1	1.0	0.002	1.9	LOSA	0.0	0.0	0.11	0.41	0.11	51.1
3	R2	All MCs	1	1.0	1	1.0	0.002	2.0	LOSA	0.0	0.0	0.11	0.41	0.11	50.6
Approach			2	1.0	2	1.0	0.002	2.0	LOSA	0.0	0.0	0.11	0.41	0.11	50.9
East: Boston Road_E															
4	L2	All MCs	1	1.0	1	1.0	0.015	5.6	LOSA	0.0	0.0	0.00	0.02	0.00	57.9
5	T1	All MCs	27	1.0	27	1.0	0.015	0.0	LOSA	0.0	0.0	0.00	0.02	0.00	59.8
Approach			28	1.0	28	1.0	0.015	0.2	NA	0.0	0.0	0.00	0.02	0.00	59.8
West: Boston Road_W															
11	T1	All MCs	37	1.0	37	1.0	0.035	0.0	LOSA	0.1	0.9	0.08	0.26	0.08	57.5
12	R2	All MCs	27	1.0	27	1.0	0.035	5.5	LOSA	0.1	0.9	0.08	0.26	0.08	53.6
Approach			64	1.0	64	1.0	0.035	2.4	NA	0.1	0.9	0.08	0.26	0.08	56.4
All Vehicles			95	1.0	95	1.0	0.035	1.7	NA	0.1	0.9	0.05	0.19	0.05	57.4

Site Level of Service (LOS) Method: Delay (SIDRA). Site LOS Method is specified in the Parameter Settings dialog (Options tab).

Vehicle movement LOS values are based on average delay per movement.

Minor Road Approach LOS values are based on average delay for all vehicle movements.

NA (TWSC): Level of Service is not defined for major road approaches or the intersection as a whole for Two-Way Sign Control (HCM LOS rule).

Two-Way Sign Control Capacity Model: SIDRA Standard.

Delay Model: SIDRA Standard (Control Delay: Geometric Delay is included).

Queue Model: SIDRA queue estimation methods are used for Back of Queue and Queue at Start of Gap.

Gap-Acceptance Capacity Formula: SIDRA Standard (Akçelik M3D).

HV (%) values are calculated for All Movement Classes of All Heavy Vehicle Model Designation.

Arrival Flows used in performance calculations are adjusted to include any Initial Queued Demand and Upstream Capacity Constraint effects.

SIDRA INTERSECTION 10.0 | Copyright © 2000-2025 Akcelik and Associates Pty Ltd | sidrasolutions.com

Organisation: URBIS | Licence: NETWORK / 1PC | Processed: Tuesday, 3 February 2026 5:00:12 PM

Project: C:\Users\lbchui\OneDrive - Urbis Ltd\P0046052 577 Boston Road Chandler - General\09_Transport\01_Analysis\P0046052_Boston Rd_SIDRA_260106.sipx

MOVEMENT SUMMARY

Site: [1BG270] Tilley Rd/ Old Cleveland Rd_2027BG__Outbound (2027 BG Outbound)

Output produced by SIDRA INTERSECTION Version: 10.0.5.217

Tilley Rd/ Old Cleveland Rd

Site Category: (None)

Signals - EQUISAT (Fixed-Time/SCATS) Isolated Cycle Time = 140.0 seconds (Site User-Given Cycle Time)

Site Scenario: 1 | Local Volumes

Vehicle Movement Performance																
Mov ID	Turn	Mov Class	Demand Flows		Arrival Flows		Deg. Satn	Aver. Delay	Level of Service	95% Back Of Queue		Prop. Qued	Eff. Stop Rate	Number of Cycles to Depart	Aver. Speed	
			[Total HV]	[Total HV]			v/c	sec				[Veh.]	[Dist]			
			veh/h	%	veh/h	%										km/h
South: Tilley Rd_S																
1	L2	All MCs	122	1.0	122	1.0	0.072	8.8	LOS A	1.3	9.0	0.29	1.19	0.29	33.4	
2	T1	All MCs	198	1.0	198	1.0	*0.730	68.8	LOS E	9.4	66.4	0.99	0.83	1.06	21.4	
3	R2	All MCs	82	1.0	82	1.0	0.469	72.4	LOS E	5.5	38.8	0.99	0.77	0.99	22.9	
Approach			402	1.0	402	1.0	0.730	51.3	LOS D	9.4	66.4	0.78	0.93	0.81	24.2	
East: Old Cleveland Rd_E																
4	L2	All MCs	52	1.0	52	1.0	0.039	27.6	LOS C	0.5	3.4	0.25	1.09	0.25	36.6	
5	T1	All MCs	1575	1.0	1575	1.0	*0.729	44.1	LOS D	34.7	244.9	0.86	0.77	0.86	40.4	
6	R2	All MCs	100	1.0	100	1.0	0.334	77.7	LOS E	6.5	45.6	0.92	0.78	0.92	29.2	
6u	U	All MCs	7	1.0	7	1.0	0.334	78.5	LOS E	6.5	45.6	0.92	0.78	0.92	30.6	
Approach			1734	1.0	1734	1.0	0.729	45.7	LOS D	34.7	244.9	0.85	0.78	0.85	34.6	
North: Tilley Rd_N																
7	L2	All MCs	43	1.0	43	1.0	0.055	20.4	LOS C	0.9	6.1	0.35	1.03	0.35	40.4	
8	T1	All MCs	147	1.0	147	1.0	0.732	75.4	LOS E	11.8	83.3	1.00	0.87	1.10	21.8	
9	R2	All MCs	336	1.0	336	1.0	*0.732	77.1	LOS E	11.8	83.3	1.00	0.87	1.08	24.2	
Approach			526	1.0	526	1.0	0.732	72.0	LOS E	11.8	83.3	0.95	0.88	1.02	23.1	
West: Old Cleveland Rd_W																
10	L2	All MCs	355	1.0	355	1.0	0.256	17.1	LOS B	1.9	13.1	0.13	0.82	0.13	44.8	
11	T1	All MCs	1488	1.0	1488	1.0	0.723	43.3	LOS D	32.7	230.9	0.89	0.79	0.89	39.0	
12	R2	All MCs	175	1.0	175	1.0	*0.730	83.1	LOS F	13.2	93.4	1.00	0.86	1.06	20.2	
12u	U	All MCs	20	1.0	20	1.0	0.730	83.9	LOS F	13.2	93.4	1.00	0.86	1.06	23.5	
Approach			2038	1.0	2038	1.0	0.730	42.5	LOS D	32.7	230.9	0.77	0.80	0.78	34.1	
All Vehicles			4700	1.0	4700	1.0	0.732	47.7	LOS D	34.7	244.9	0.82	0.82	0.83	31.9	

Site Level of Service (LOS) Method: Delay (SIDRA). Site LOS Method is specified in the Parameter Settings dialog (Options tab).

Vehicle movement LOS values are based on average delay per movement.

Intersection and Approach LOS values are based on average delay for all vehicle movements.

Delay Model: SIDRA Standard (Control Delay; Geometric Delay is included).

Queue Model: SIDRA queue estimation methods are used for Back of Queue and Queue at Start of Green.

Gap-Acceptance Capacity Formula: SIDRA Standard (Akçelik M3D).

HV (%) values are calculated for All Movement Classes of All Heavy Vehicle Model Designation.

Arrival Flows used in performance calculations are adjusted to include any Initial Queued Demand and Upstream Capacity Constraint effects.

* Critical Movement (Signal Timing)

Pedestrian Movement Performance											
Mov ID	Crossing	Input Vol.	Dem. Flow	Aver. Delay	Level of Service	AVERAGE BACK OF QUEUE	Prop. Qued	Eff. Stop	Travel Time	Travel Dist.	Aver. Speed

	ped/h	ped/h	sec		[Ped ped	Dist] m		Rate		sec	m	m/sec
West: Old Cleveland Rd_W												
P41 Stage 1	2	2	64.1	LOS F	0.0	0.0		0.96	0.96	218.0	200.0	0.92
P42 Stage 2	2	2	64.1	LOS F	0.0	0.0		0.96	0.96	218.0	200.0	0.92
All Pedestrians	4	4	64.1	LOS F	0.0	0.0		0.96	0.96	218.0	200.0	0.92

Level of Service (LOS) Method: SIDRA Pedestrian LOS Method (Based on Average Delay)

Pedestrian movement LOS values are based on average delay per pedestrian movement.

Intersection LOS value for Pedestrians is based on average delay for all pedestrian movements.

SIDRA INTERSECTION 10.0 | Copyright © 2000-2025 Akcelik and Associates Pty Ltd | sidrasolutions.com

Organisation: URBIS | Licence: NETWORK / 1PC | Processed: Tuesday, 3 February 2026 5:00:13 PM

Project: C:\Users\bchui\OneDrive - Urbis Ltd\P0046052 577 Boston Road Chandler - General\09_Transport\01_Analysis\P0046052_Boston Rd_SIDRA_260106.sipx

MOVEMENT SUMMARY

Site: [2BG270] Archer St/ Old Cleveland Rd_2027BG__Outbound (2027 BG Outbound)

Output produced by SIDRA INTERSECTION Version: 10.0.5.217

Archer St/ Old Cleveland Rd
 Site Category: (None)
 Give-Way (Two-Way)
Site Scenario: 1 | Local Volumes

Vehicle Movement Performance															
Mov ID	Turn	Mov Class	Demand Flows	Arrival Flows	Deg. Satn	Aver. Delay	Level of Service	95% Back Of Queue	Prop. Qued	Eff. Stop Rate	Number of Cycles to Depart	Aver. Speed			
			[Total HV]	[Total HV]	v/c	sec		[Veh.]	[Dist]			km/h			
			veh/h	%	veh/h	%		veh	m						
East: Old Cleveland Rd_E															
5	T1	All MCs	1667	1.0	1667	1.0	0.430	0.1	LOSA	0.0	0.0	0.00	0.00	0.00	69.7
Approach			1667	1.0	1667	1.0	0.430	0.1	NA	0.0	0.0	0.00	0.00	0.00	69.7
North: Archer St_N															
7	L2	All MCs	80	1.0	80	1.0	0.043	5.0	LOSA	0.0	0.0	0.00	0.52	0.00	50.3
Approach			80	1.0	80	1.0	0.043	5.0	NA	0.0	0.0	0.00	0.52	0.00	50.3
West: Old Cleveland Rd_E															
10	L2	All MCs	41	1.0	41	1.0	0.022	6.7	LOSA	0.0	0.0	0.00	0.57	0.00	54.0
11	T1	All MCs	1507	1.0	1507	1.0	0.389	0.1	LOSA	0.0	0.0	0.00	0.00	0.00	69.7
Approach			1548	1.0	1548	1.0	0.389	0.3	NA	0.0	0.0	0.00	0.02	0.00	69.4
All Vehicles			3296	1.0	3296	1.0	0.430	0.3	NA	0.0	0.0	0.00	0.02	0.00	69.1

Site Level of Service (LOS) Method: Delay (SIDRA). Site LOS Method is specified in the Parameter Settings dialog (Options tab).
 Vehicle movement LOS values are based on average delay per movement.
 Minor Road Approach LOS values are based on average delay for all vehicle movements.
 NA (TWSC): Level of Service is not defined for major road approaches or the intersection as a whole for Two-Way Sign Control (HCM LOS rule).
 Two-Way Sign Control Capacity Model: SIDRA Standard.
 Delay Model: SIDRA Standard (Control Delay: Geometric Delay is included).
 Queue Model: SIDRA queue estimation methods are used for Back of Queue and Queue at Start of Gap.
 Gap-Acceptance Capacity Formula: SIDRA Standard (Akçelik M3D).
 HV (%) values are calculated for All Movement Classes of All Heavy Vehicle Model Designation.
 Arrival Flows used in performance calculations are adjusted to include any Initial Queued Demand and Upstream Capacity Constraint effects.

MOVEMENT SUMMARY

Site: [3BG270] Tilley Rd/ Boston Rd_2027BG_Outbound
(2027 BG Outbound)

Output produced by SIDRA INTERSECTION Version: 10.0.5.217

Tilley Rd/ Boston Rd
Site Category: (None)
Give-Way (Two-Way)
Site Scenario: 1 | Local Volumes

Vehicle Movement Performance															
Mov ID	Turn	Mov Class	Demand Flows		Arrival Flows		Deg. Satn	Aver. Delay	Level of Service	95% Back Of Queue		Prop. Qued	Eff. Stop Rate	Number of Cycles to Depart	Aver. Speed
			[Total HV]	[Total HV]	[Total HV]	[Total HV]	v/c	sec		[Veh.]	[Dist]				km/h
			veh/h	%	veh/h	%				veh	m				
South: Tilley Road_S															
1	L2	All MCs	14	1.0	14	1.0	0.348	8.1	LOS A	0.2	1.4	0.04	0.06	0.04	60.4
2	T1	All MCs	631	1.0	631	1.0	0.348	0.1	LOS A	0.2	1.4	0.04	0.06	0.04	69.2
3	R2	All MCs	16	1.0	16	1.0	0.348	8.7	LOS A	0.2	1.4	0.04	0.06	0.04	60.0
Approach			660	1.0	660	1.0	0.348	0.5	NA	0.2	1.4	0.04	0.06	0.04	68.7
East: Boston Road_E															
4	L2	All MCs	39	1.0	39	1.0	0.090	7.5	LOS A	0.3	2.1	0.59	0.76	0.59	50.5
5	T1	All MCs	3	1.0	3	1.0	0.090	14.3	LOS B	0.3	2.1	0.59	0.76	0.59	50.0
6	R2	All MCs	11	1.0	11	1.0	0.090	18.3	LOS C	0.3	2.1	0.59	0.76	0.59	50.5
Approach			53	1.0	53	1.0	0.090	10.1	LOS B	0.3	2.1	0.59	0.76	0.59	50.5
North: Tilley Road_N															
7	L2	All MCs	5	1.0	5	1.0	0.262	8.8	LOS A	0.1	0.8	0.03	0.04	0.03	60.7
8	T1	All MCs	488	1.0	488	1.0	0.262	0.1	LOS A	0.1	0.8	0.03	0.04	0.03	69.5
9	R2	All MCs	6	1.0	6	1.0	0.262	9.6	LOS A	0.1	0.8	0.03	0.04	0.03	60.3
Approach			500	1.0	500	1.0	0.262	0.3	NA	0.1	0.8	0.03	0.04	0.03	69.2
West: Boston Road_W															
10	L2	All MCs	1	1.0	1	1.0	0.084	8.3	LOS A	0.3	1.8	0.77	0.90	0.77	47.0
11	T1	All MCs	15	1.0	15	1.0	0.084	13.8	LOS B	0.3	1.8	0.77	0.90	0.77	46.6
12	R2	All MCs	9	1.0	9	1.0	0.084	18.4	LOS C	0.3	1.8	0.77	0.90	0.77	46.5
Approach			25	1.0	25	1.0	0.084	15.3	LOS C	0.3	1.8	0.77	0.90	0.77	46.6
All Vehicles			1238	1.0	1238	1.0	0.348	1.1	NA	0.3	2.1	0.07	0.10	0.07	67.0

Site Level of Service (LOS) Method: Delay (SIDRA). Site LOS Method is specified in the Parameter Settings dialog (Options tab).
 Vehicle movement LOS values are based on average delay per movement.
 Minor Road Approach LOS values are based on average delay for all vehicle movements.
 NA (TWSC): Level of Service is not defined for major road approaches or the intersection as a whole for Two-Way Sign Control (HCM LOS rule).
 Two-Way Sign Control Capacity Model: SIDRA Standard.
 Delay Model: SIDRA Standard (Control Delay: Geometric Delay is included).
 Queue Model: SIDRA queue estimation methods are used for Back of Queue and Queue at Start of Gap.
 Gap-Acceptance Capacity Formula: SIDRA Standard (Akçelik M3D).
 HV (%) values are calculated for All Movement Classes of All Heavy Vehicle Model Designation.
 Arrival Flows used in performance calculations are adjusted to include any Initial Queued Demand and Upstream Capacity Constraint effects.

MOVEMENT SUMMARY

Site: [4BG270] Boston Rd/ Archer St_2027BG__Outbound
(2027 BG Outbound)

Output produced by SIDRA INTERSECTION Version: 10.0.5.217

Boston Rd/ Archer St
Site Category: (None)
Give-Way (Two-Way)
Site Scenario: 1 | Local Volumes

Vehicle Movement Performance															
Mov ID	Turn	Mov Class	Demand Flows		Arrival Flows		Deg. Satn	Aver. Delay	Level of Service	95% Back Of Queue		Prop. Qued	Eff. Stop of Cycles	Number of Cycles	Aver. Speed
			[Total HV]	[Total HV]	[Total HV]	[Total HV]	v/c	sec		[Veh.]	[Dist]		Rate to Depart		km/h
			veh/h	%	veh/h	%				veh	m				
South: Archer Street_S															
1	L2	All MCs	1	1.0	1	1.0	0.024	5.2	LOS A	0.0	0.3	0.07	0.11	0.07	54.2
2	T1	All MCs	38	1.0	38	1.0	0.024	0.1	LOS A	0.0	0.3	0.07	0.11	0.07	57.9
3	R2	All MCs	6	1.0	6	1.0	0.024	5.1	LOS A	0.0	0.3	0.07	0.11	0.07	53.7
Approach			45	1.0	45	1.0	0.024	0.9	NA	0.0	0.3	0.07	0.11	0.07	57.1
East: Boston Road_E															
4	L2	All MCs	1	1.0	1	1.0	0.022	5.8	LOS A	0.1	0.5	0.23	0.54	0.23	48.7
5	T1	All MCs	14	1.0	14	1.0	0.022	4.7	LOS A	0.1	0.5	0.23	0.54	0.23	53.2
6	R2	All MCs	9	1.0	9	1.0	0.022	6.2	LOS A	0.1	0.5	0.23	0.54	0.23	51.8
Approach			24	1.0	24	1.0	0.022	5.3	LOS A	0.1	0.5	0.23	0.54	0.23	52.6
North: Archer Street_N															
7	L2	All MCs	16	1.0	16	1.0	0.056	5.6	LOS A	0.1	0.6	0.04	0.16	0.04	55.6
8	T1	All MCs	78	1.0	78	1.0	0.056	0.0	LOS A	0.1	0.6	0.04	0.16	0.04	56.9
9	R2	All MCs	12	1.0	12	1.0	0.056	5.5	LOS A	0.1	0.6	0.04	0.16	0.04	55.3
Approach			105	1.0	105	1.0	0.056	1.5	NA	0.1	0.6	0.04	0.16	0.04	56.3
West: Boston Road_W															
10	L2	All MCs	7	1.0	7	1.0	0.031	5.7	LOS A	0.1	0.8	0.19	0.55	0.19	51.9
11	T1	All MCs	9	1.0	9	1.0	0.031	4.7	LOS A	0.1	0.8	0.19	0.55	0.19	53.1
12	R2	All MCs	18	1.0	18	1.0	0.031	6.1	LOS A	0.1	0.8	0.19	0.55	0.19	48.0
Approach			35	1.0	35	1.0	0.031	5.6	LOS A	0.1	0.8	0.19	0.55	0.19	50.7
All Vehicles			209	1.0	209	1.0	0.056	2.5	NA	0.1	0.8	0.09	0.26	0.09	54.6

Site Level of Service (LOS) Method: Delay (SIDRA). Site LOS Method is specified in the Parameter Settings dialog (Options tab).
 Vehicle movement LOS values are based on average delay per movement.
 Minor Road Approach LOS values are based on average delay for all vehicle movements.
 NA (TWSC): Level of Service is not defined for major road approaches or the intersection as a whole for Two-Way Sign Control (HCM LOS rule).
 Two-Way Sign Control Capacity Model: SIDRA Standard.
 Delay Model: SIDRA Standard (Control Delay: Geometric Delay is included).
 Queue Model: SIDRA queue estimation methods are used for Back of Queue and Queue at Start of Gap.
 Gap-Acceptance Capacity Formula: SIDRA Standard (Akçelik M3D).
 HV (%) values are calculated for All Movement Classes of All Heavy Vehicle Model Designation.
 Arrival Flows used in performance calculations are adjusted to include any Initial Queued Demand and Upstream Capacity Constraint effects.

MOVEMENT SUMMARY

Site: [5BG270] Boston Rd/ Site Access_2027BG__Outbound
(2027 BG Outbound)

Output produced by SIDRA INTERSECTION Version: 10.0.5.217

Boston Rd/ Site Access

Site Category: (None)

Give-Way (Two-Way)

Site Scenario: 1 | Local Volumes

Vehicle Movement Performance															
Mov ID	Turn	Mov Class	Demand Flows		Arrival Flows		Deg. Satn	Aver. Delay	Level of Service	95% Back Of Queue		Prop. Qued	Eff. Stop of Cycles Rate to Depart	Number of Cycles	Aver. Speed
			[Total HV]	[Total HV]	[Total HV]	[Total HV]	v/c	sec		[Veh.]	[Dist]				km/h
			veh/h	%	veh/h	%				veh	m				
South: Site Access_S															
1	L2	All MCs	21	1.0	21	1.0	0.019	1.9	LOS A	0.1	0.5	0.09	0.41	0.09	51.1
3	R2	All MCs	7	1.0	7	1.0	0.019	2.0	LOS A	0.1	0.5	0.09	0.41	0.09	50.6
Approach			28	1.0	28	1.0	0.019	1.9	LOS A	0.1	0.5	0.09	0.41	0.09	51.0
East: Boston Road_E															
4	L2	All MCs	1	1.0	1	1.0	0.015	5.6	LOS A	0.0	0.0	0.00	0.02	0.00	57.9
5	T1	All MCs	27	1.0	27	1.0	0.015	0.0	LOS A	0.0	0.0	0.00	0.02	0.00	59.8
Approach			28	1.0	28	1.0	0.015	0.2	NA	0.0	0.0	0.00	0.02	0.00	59.8
West: Boston Road_W															
11	T1	All MCs	37	1.0	37	1.0	0.020	0.0	LOS A	0.0	0.0	0.01	0.02	0.01	59.8
12	R2	All MCs	1	1.0	1	1.0	0.020	5.5	LOS A	0.0	0.0	0.01	0.02	0.01	57.6
Approach			38	1.0	38	1.0	0.020	0.2	NA	0.0	0.0	0.01	0.02	0.01	59.8
All Vehicles			95	1.0	95	1.0	0.020	0.7	NA	0.1	0.5	0.03	0.14	0.03	57.9

Site Level of Service (LOS) Method: Delay (SIDRA). Site LOS Method is specified in the Parameter Settings dialog (Options tab).

Vehicle movement LOS values are based on average delay per movement.

Minor Road Approach LOS values are based on average delay for all vehicle movements.

NA (TWSC): Level of Service is not defined for major road approaches or the intersection as a whole for Two-Way Sign Control (HCM LOS rule).

Two-Way Sign Control Capacity Model: SIDRA Standard.

Delay Model: SIDRA Standard (Control Delay: Geometric Delay is included).

Queue Model: SIDRA queue estimation methods are used for Back of Queue and Queue at Start of Gap.

Gap-Acceptance Capacity Formula: SIDRA Standard (Akçelik M3D).

HV (%) values are calculated for All Movement Classes of All Heavy Vehicle Model Designation.

Arrival Flows used in performance calculations are adjusted to include any Initial Queued Demand and Upstream Capacity Constraint effects.

SIDRA INTERSECTION 10.0 | Copyright © 2000-2025 Akcelik and Associates Pty Ltd | sidrasolutions.com

Organisation: URBIS | Licence: NETWORK / 1PC | Processed: Tuesday, 3 February 2026 5:00:14 PM

Project: C:\Users\lbchui\OneDrive - Urbis Ltd\P0046052 577 Boston Road Chandler - General\09_Transport\01_Analysis\P0046052_Boston Rd_SIDRA_260106.sipx

MOVEMENT SUMMARY

Site: [1D27I] Tilley Rd/ Old Cleveland Rd_2027Dev_Inbound
(2027 Dev_Inbound)

Output produced by SIDRA INTERSECTION Version: 10.0.8.241

Tilley Rd/ Old Cleveland Rd

Site Category: (None)

Signals - EQUISAT (Fixed-Time/SCATS) Isolated Cycle Time = 140.0 seconds (Site User-Given Cycle Time)

Site Scenario: 1 | Local Volumes

Vehicle Movement Performance															
Mov ID	Turn	Mov Class	Demand Flows		Arrival Flows		Deg. Satn	Aver. Delay	Level of Service	95% Back Of Queue		Prop. Qued	Eff. Stop Rate	Number of Cycles to Depart	Aver. Speed
			[Total HV]	[Total HV]	[Total HV]	[Total HV]	v/c	sec		[Veh.]	[Dist]				km/h
			veh/h	%	veh/h	%				veh	m				
South: Tilley Rd_S															
1	L2	All MCs	122	1.0	122	1.0	0.073	10.0	LOS A	1.7	11.9	0.33	1.33	0.33	30.4
2	T1	All MCs	198	1.0	198	1.0	*0.720	68.5	LOS E	9.4	66.2	0.99	0.82	1.05	21.5
3	R2	All MCs	82	1.0	82	1.0	0.463	72.1	LOS E	5.5	38.7	0.99	0.77	0.99	23.0
Approach			402	1.0	402	1.0	0.720	51.5	LOS D	9.4	66.2	0.79	0.97	0.82	23.7
East: Old Cleveland Rd_E															
4	L2	All MCs	52	1.0	52	1.0	0.038	26.0	LOS C	0.3	2.3	0.19	0.96	0.19	38.7
5	T1	All MCs	1575	1.0	1575	1.0	*0.720	42.4	LOS D	34.5	243.9	0.85	0.76	0.85	41.0
6	R2	All MCs	140	1.0	140	1.0	0.449	77.5	LOS E	9.1	64.0	0.94	0.80	0.94	29.0
6u	U	All MCs	7	1.0	7	1.0	0.449	78.2	LOS E	9.1	64.0	0.94	0.80	0.94	30.4
Approach			1774	1.0	1774	1.0	0.720	44.8	LOS D	34.5	243.9	0.84	0.77	0.84	34.9
North: Tilley Rd_N															
7	L2	All MCs	43	1.0	43	1.0	0.062	23.3	LOS C	0.8	5.4	0.32	1.10	0.32	38.5
8	T1	All MCs	147	1.0	147	1.0	0.703	78.7	LOS E	10.1	71.4	1.00	0.85	1.07	21.9
9	R2	All MCs	322	1.0	322	1.0	*0.721	75.2	LOS E	11.1	78.2	1.00	0.86	1.07	24.0
Approach			513	1.0	513	1.0	0.721	71.8	LOS E	11.1	78.2	0.94	0.88	1.01	23.0
West: Old Cleveland Rd_W															
10	L2	All MCs	435	1.0	435	1.0	0.307	15.8	LOS B	2.4	17.0	0.17	1.09	0.17	43.6
11	T1	All MCs	1488	1.0	1488	1.0	0.713	41.7	LOS D	32.6	229.9	0.88	0.83	0.88	39.4
12	R2	All MCs	175	1.0	175	1.0	*0.720	82.1	LOS F	13.2	92.9	1.00	0.86	1.05	20.3
12u	U	All MCs	20	1.0	20	1.0	0.720	83.0	LOS F	13.2	92.9	1.00	0.86	1.05	23.6
Approach			2118	1.0	2118	1.0	0.720	40.1	LOS D	32.6	229.9	0.75	0.89	0.75	34.7
All Vehicles			4806	1.0	4806	1.0	0.721	46.2	LOS D	34.5	243.9	0.81	0.85	0.82	32.2

Site Level of Service (LOS) Method: Delay (SIDRA). Site LOS Method is specified in the Parameter Settings dialog (Options tab).

Vehicle movement LOS values are based on average delay per movement.

Intersection and Approach LOS values are based on average delay for all vehicle movements.

Delay Model: SIDRA Standard (Control Delay; Geometric Delay is included).

Queue Model: SIDRA queue estimation methods are used for Back of Queue and Queue at Start of Green.

Gap-Acceptance Capacity Formula: SIDRA Standard (Akçelik M3D).

HV (%) values are calculated for All Movement Classes of All Heavy Vehicle Model Designation.

Arrival Flows used in performance calculations are adjusted to include any Initial Queued Demand and Upstream Capacity Constraint effects.

* Critical Movement (Signal Timing)

Pedestrian Movement Performance											
Mov ID	Crossing	Input Vol.	Dem. Flow	Aver. Delay	Level of Service	AVERAGE BACK OF QUEUE	Prop. Qued	Eff. Stop	Travel Time	Travel Dist.	Aver. Speed

	ped/h	ped/h	sec		[Ped ped	Dist] m		Rate		sec	m	m/sec
West: Old Cleveland Rd_W												
P41 Stage 1	2	2	64.1	LOS F	0.0	0.0		0.96	0.96	218.0	200.0	0.92
P42 Stage 2	2	2	64.1	LOS F	0.0	0.0		0.96	0.96	218.0	200.0	0.92
All Pedestrians	4	4	64.1	LOS F	0.0	0.0		0.96	0.96	218.0	200.0	0.92

Level of Service (LOS) Method: SIDRA Pedestrian LOS Method (Based on Average Delay)

Pedestrian movement LOS values are based on average delay per pedestrian movement.

Intersection LOS value for Pedestrians is based on average delay for all pedestrian movements.

SIDRA INTERSECTION 10.0 | Copyright © 2000-2025 Akcelik and Associates Pty Ltd | sidrasolutions.com

Organisation: URBIS | Licence: NETWORK / 1PC | Processed: Thursday, 5 February 2026 12:34:27 PM

Project: C:\Users\bchui\OneDrive - Urbis Ltd\P0046052 577 Boston Road Chandler - General\09_Transport\01_Analysis\P0046052_Boston Rd_SIDRA_260106.sipx

MOVEMENT SUMMARY

Site: [2D27I] Archer St/ Old Cleveland Rd_2027Dev_Inbound
(2027 Dev_Inbound)

Output produced by SIDRA INTERSECTION Version: 10.0.5.217

Archer St/ Old Cleveland Rd

Site Category: (None)

Give-Way (Two-Way)

Site Scenario: 1 | Local Volumes

Vehicle Movement Performance															
Mov ID	Turn	Mov Class	Demand Flows	Arrival Flows	Deg. Satn	Aver. Delay	Level of Service	95% Back Of Queue	Prop. Qued	Eff. Stop Rate	Number of Cycles to Depart	Aver. Speed			
			[Total HV]	[Total HV]	v/c	sec		[Veh. Dist]				km/h			
			veh/h	%	veh/h	%		veh	m						
East: Old Cleveland Rd_E															
5	T1	All MCs	1707	1.0	1707	1.0	0.441	0.1	LOSA	0.0	0.0	0.00	0.00	0.00	69.6
Approach			1707	1.0	1707	1.0	0.441	0.1	NA	0.0	0.0	0.00	0.00	0.00	69.6
North: Archer St_N															
7	L2	All MCs	74	1.0	74	1.0	0.040	5.0	LOSA	0.0	0.0	0.00	0.52	0.00	50.3
Approach			74	1.0	74	1.0	0.040	5.0	NA	0.0	0.0	0.00	0.52	0.00	50.3
West: Old Cleveland Rd_E															
10	L2	All MCs	41	1.0	41	1.0	0.022	6.7	LOSA	0.0	0.0	0.00	0.57	0.00	54.0
11	T1	All MCs	1507	1.0	1507	1.0	0.389	0.1	LOSA	0.0	0.0	0.00	0.00	0.00	69.7
Approach			1548	1.0	1548	1.0	0.389	0.3	NA	0.0	0.0	0.00	0.02	0.00	69.4
All Vehicles			3329	1.0	3329	1.0	0.441	0.3	NA	0.0	0.0	0.00	0.02	0.00	69.2

Site Level of Service (LOS) Method: Delay (SIDRA). Site LOS Method is specified in the Parameter Settings dialog (Options tab).

Vehicle movement LOS values are based on average delay per movement.

Minor Road Approach LOS values are based on average delay for all vehicle movements.

NA (TWSC): Level of Service is not defined for major road approaches or the intersection as a whole for Two-Way Sign Control (HCM LOS rule).

Two-Way Sign Control Capacity Model: SIDRA Standard.

Delay Model: SIDRA Standard (Control Delay: Geometric Delay is included).

Queue Model: SIDRA queue estimation methods are used for Back of Queue and Queue at Start of Gap.

Gap-Acceptance Capacity Formula: SIDRA Standard (Akçelik M3D).

HV (%) values are calculated for All Movement Classes of All Heavy Vehicle Model Designation.

Arrival Flows used in performance calculations are adjusted to include any Initial Queued Demand and Upstream Capacity Constraint effects.

SIDRA INTERSECTION 10.0 | Copyright © 2000-2025 Akcelik and Associates Pty Ltd | sidrasolutions.com

Organisation: URBIS | Licence: NETWORK / 1PC | Processed: Tuesday, 3 February 2026 5:00:15 PM

Project: C:\Users\bchui\OneDrive - Urbis Ltd\P0046052 577 Boston Road Chandler - General\09_Transport\01_Analysis\P0046052_Boston Rd_SIDRA_260106.sipx

MOVEMENT SUMMARY

Site: [3D27I] Tilley Rd/ Boston Rd_2027Dev_Inbound (2027 Dev_Inbound)

Output produced by SIDRA INTERSECTION Version: 10.0.5.217

Tilley Rd/ Boston Rd
 Site Category: (None)
 Give-Way (Two-Way)

Site Scenario: 1 | Local Volumes

Vehicle Movement Performance															
Mov ID	Turn	Mov Class	Demand Flows		Arrival Flows		Deg. Satn	Aver. Delay	Level of Service	95% Back Of Queue		Prop. Qued	Eff. Stop Rate	Number of Cycles to Depart	Aver. Speed
			[Total HV]	%	[Total HV]	%	v/c	sec		[Veh.]	[Dist]				km/h
			veh/h		veh/h					veh	m				
South: Tilley Road_S															
1	L2	All MCs	14	1.0	14	1.0	0.469	9.8	LOS A	2.3	16.1	0.26	0.34	0.36	57.7
2	T1	All MCs	631	1.0	631	1.0	0.469	1.4	LOS A	2.3	16.1	0.26	0.34	0.36	65.4
3	R2	All MCs	136	1.0	136	1.0	0.469	9.7	LOS A	2.3	16.1	0.26	0.34	0.36	57.3
Approach			780	1.0	780	1.0	0.469	3.0	NA	2.3	16.1	0.26	0.34	0.36	63.5
East: Boston Road_E															
4	L2	All MCs	25	1.0	25	1.0	0.054	7.4	LOS A	0.2	1.3	0.59	0.72	0.59	50.6
5	T1	All MCs	3	1.0	3	1.0	0.054	17.5	LOS C	0.2	1.3	0.59	0.72	0.59	50.1
6	R2	All MCs	3	1.0	3	1.0	0.054	22.3	LOS C	0.2	1.3	0.59	0.72	0.59	50.6
Approach			32	1.0	32	1.0	0.054	9.9	LOS A	0.2	1.3	0.59	0.72	0.59	50.6
North: Tilley Road_N															
7	L2	All MCs	45	1.0	45	1.0	0.284	7.0	LOS A	0.1	0.9	0.03	0.09	0.03	60.2
8	T1	All MCs	488	1.0	488	1.0	0.284	0.1	LOS A	0.1	0.9	0.03	0.09	0.03	68.7
9	R2	All MCs	6	1.0	6	1.0	0.284	9.6	LOS A	0.1	0.9	0.03	0.09	0.03	59.8
Approach			540	1.0	540	1.0	0.284	0.8	NA	0.1	0.9	0.03	0.09	0.03	67.7
West: Boston Road_W															
10	L2	All MCs	1	1.0	1	1.0	0.109	8.3	LOS A	0.3	2.3	0.82	0.92	0.82	44.6
11	T1	All MCs	15	1.0	15	1.0	0.109	17.8	LOS C	0.3	2.3	0.82	0.92	0.82	44.5
12	R2	All MCs	9	1.0	9	1.0	0.109	22.1	LOS C	0.3	2.3	0.82	0.92	0.82	44.2
Approach			25	1.0	25	1.0	0.109	19.0	LOS C	0.3	2.3	0.82	0.92	0.82	44.4
All Vehicles			1377	1.0	1377	1.0	0.469	2.6	NA	2.3	16.1	0.19	0.26	0.25	64.1

Site Level of Service (LOS) Method: Delay (SIDRA). Site LOS Method is specified in the Parameter Settings dialog (Options tab).
 Vehicle movement LOS values are based on average delay per movement.
 Minor Road Approach LOS values are based on average delay for all vehicle movements.
 NA (TWSC): Level of Service is not defined for major road approaches or the intersection as a whole for Two-Way Sign Control (HCM LOS rule).
 Two-Way Sign Control Capacity Model: SIDRA Standard.
 Delay Model: SIDRA Standard (Control Delay: Geometric Delay is included).
 Queue Model: SIDRA queue estimation methods are used for Back of Queue and Queue at Start of Gap.
 Gap-Acceptance Capacity Formula: SIDRA Standard (Akçelik M3D).
 HV (%) values are calculated for All Movement Classes of All Heavy Vehicle Model Designation.
 Arrival Flows used in performance calculations are adjusted to include any Initial Queued Demand and Upstream Capacity Constraint effects.

MOVEMENT SUMMARY

Site: [4D27I] Boston Rd/ Archer St_2027Dev_Inbound (2027 Dev_Inbound)

Output produced by SIDRA INTERSECTION Version: 10.0.5.217

Boston Rd/ Archer St
 Site Category: (None)
 Give-Way (Two-Way)
 Site Scenario: 1 | Local Volumes

Vehicle Movement Performance															
Mov ID	Turn	Mov Class	Demand Flows		Arrival Flows		Deg. Satn	Aver. Delay	Level of Service	95% Back Of Queue		Prop. Qued	Eff. Stop of Cycles	Number of Cycles	Aver. Speed
			[Total HV]	[Total HV]			v/c	sec	[Veh. Dist]				Rate to Depart	km/h	
			veh/h	%	veh/h	%									
South: Archer Street_S															
1	L2	All MCs	1	1.0	1	1.0	0.024	5.2	LOS A	0.0	0.3	0.07	0.11	0.07	54.2
2	T1	All MCs	38	1.0	38	1.0	0.024	0.1	LOS A	0.0	0.3	0.07	0.11	0.07	57.9
3	R2	All MCs	6	1.0	6	1.0	0.024	5.1	LOS A	0.0	0.3	0.07	0.11	0.07	53.7
Approach			45	1.0	45	1.0	0.024	0.9	NA	0.0	0.3	0.07	0.11	0.07	57.1
East: Boston Road_E															
4	L2	All MCs	1	1.0	1	1.0	0.022	5.8	LOS A	0.1	0.5	0.23	0.54	0.23	48.7
5	T1	All MCs	14	1.0	14	1.0	0.022	4.7	LOS A	0.1	0.5	0.23	0.54	0.23	53.2
6	R2	All MCs	9	1.0	9	1.0	0.022	6.2	LOS A	0.1	0.5	0.23	0.54	0.23	51.8
Approach			24	1.0	24	1.0	0.022	5.3	LOS A	0.1	0.5	0.23	0.54	0.23	52.6
North: Archer Street_N															
7	L2	All MCs	16	1.0	16	1.0	0.056	5.6	LOS A	0.1	0.6	0.04	0.16	0.04	55.6
8	T1	All MCs	78	1.0	78	1.0	0.056	0.0	LOS A	0.1	0.6	0.04	0.16	0.04	56.9
9	R2	All MCs	12	1.0	12	1.0	0.056	5.5	LOS A	0.1	0.6	0.04	0.16	0.04	55.3
Approach			105	1.0	105	1.0	0.056	1.5	NA	0.1	0.6	0.04	0.16	0.04	56.3
West: Boston Road_W															
10	L2	All MCs	7	1.0	7	1.0	0.024	5.7	LOS A	0.1	0.6	0.18	0.54	0.18	52.0
11	T1	All MCs	9	1.0	9	1.0	0.024	4.7	LOS A	0.1	0.6	0.18	0.54	0.18	53.2
12	R2	All MCs	11	1.0	11	1.0	0.024	6.1	LOS A	0.1	0.6	0.18	0.54	0.18	48.1
Approach			27	1.0	27	1.0	0.024	5.5	LOS A	0.1	0.6	0.18	0.54	0.18	51.4
All Vehicles			202	1.0	202	1.0	0.056	2.3	NA	0.1	0.6	0.09	0.24	0.09	54.9

Site Level of Service (LOS) Method: Delay (SIDRA). Site LOS Method is specified in the Parameter Settings dialog (Options tab).
 Vehicle movement LOS values are based on average delay per movement.
 Minor Road Approach LOS values are based on average delay for all vehicle movements.
 NA (TWSC): Level of Service is not defined for major road approaches or the intersection as a whole for Two-Way Sign Control (HCM LOS rule).
 Two-Way Sign Control Capacity Model: SIDRA Standard.
 Delay Model: SIDRA Standard (Control Delay: Geometric Delay is included).
 Queue Model: SIDRA queue estimation methods are used for Back of Queue and Queue at Start of Gap.
 Gap-Acceptance Capacity Formula: SIDRA Standard (Akçelik M3D).
 HV (%) values are calculated for All Movement Classes of All Heavy Vehicle Model Designation.
 Arrival Flows used in performance calculations are adjusted to include any Initial Queued Demand and Upstream Capacity Constraint effects.

MOVEMENT SUMMARY

Site: [5D271] Boston Rd/ Site Access_2027Dev_Inbound
(2027 Dev_Inbound)

Output produced by SIDRA INTERSECTION Version: 10.0.5.217

Boston Rd/ Site Access
Site Category: (None)
Give-Way (Two-Way)
Site Scenario: 1 | Local Volumes

Vehicle Movement Performance															
Mov ID	Turn	Mov Class	Demand Flows		Arrival Flows		Deg. Satn	Aver. Delay	Level of Service	95% Back Of Queue		Prop. Qued	Eff. Stop of Cycles	Number of Cycles to Depart	Aver. Speed
			[Total HV]	[Total HV]	[Total HV]	[Total HV]	v/c	sec		[Veh.]	[Dist]		Rate		km/h
			veh/h	%	veh/h	%				veh	m				
South: Site Access_S															
1	L2	All MCs	1	1.0	1	1.0	0.002	1.9	LOSA	0.0	0.0	0.12	0.40	0.12	50.9
3	R2	All MCs	1	1.0	1	1.0	0.002	2.5	LOSA	0.0	0.0	0.12	0.40	0.12	50.4
Approach			2	1.0	2	1.0	0.002	2.2	LOSA	0.0	0.0	0.12	0.40	0.12	50.7
East: Boston Road_E															
4	L2	All MCs	1	1.0	1	1.0	0.015	5.6	LOSA	0.0	0.0	0.00	0.02	0.00	57.9
5	T1	All MCs	27	1.0	27	1.0	0.015	0.0	LOSA	0.0	0.0	0.00	0.02	0.00	59.8
Approach			28	1.0	28	1.0	0.015	0.2	NA	0.0	0.0	0.00	0.02	0.00	59.8
West: Boston Road_W															
11	T1	All MCs	37	1.0	37	1.0	0.111	0.1	LOSA	0.5	3.9	0.10	0.47	0.10	55.6
12	R2	All MCs	160	1.0	160	1.0	0.111	5.5	LOSA	0.5	3.9	0.10	0.47	0.10	50.5
Approach			197	1.0	197	1.0	0.111	4.5	NA	0.5	3.9	0.10	0.47	0.10	51.9
All Vehicles			227	1.0	227	1.0	0.111	4.0	NA	0.5	3.9	0.09	0.41	0.09	53.2

Site Level of Service (LOS) Method: Delay (SIDRA). Site LOS Method is specified in the Parameter Settings dialog (Options tab).

Vehicle movement LOS values are based on average delay per movement.

Minor Road Approach LOS values are based on average delay for all vehicle movements.

NA (TWSC): Level of Service is not defined for major road approaches or the intersection as a whole for Two-Way Sign Control (HCM LOS rule).

Two-Way Sign Control Capacity Model: SIDRA Standard.

Delay Model: SIDRA Standard (Control Delay: Geometric Delay is included).

Queue Model: SIDRA queue estimation methods are used for Back of Queue and Queue at Start of Gap.

Gap-Acceptance Capacity Formula: SIDRA Standard (Akçelik M3D).

HV (%) values are calculated for All Movement Classes of All Heavy Vehicle Model Designation.

Arrival Flows used in performance calculations are adjusted to include any Initial Queued Demand and Upstream Capacity Constraint effects.

SIDRA INTERSECTION 10.0 | Copyright © 2000-2025 Akcelik and Associates Pty Ltd | sidrasolutions.com

Organisation: URBIS | Licence: NETWORK / 1PC | Processed: Tuesday, 3 February 2026 5:00:16 PM

Project: C:\Users\lbchui\OneDrive - Urbis Ltd\P0046052 577 Boston Road Chandler - General\09_Transport\01_Analysis\P0046052_Boston Rd_SIDRA_260106.sipx

MOVEMENT SUMMARY

 **Site: [1D270] Tilley Rd/ Old Cleveland Rd_2027Dev_Outbound**
(2027 Dev_Outbound)

Output produced by SIDRA INTERSECTION Version: 10.0.8.241

Tilley Rd/ Old Cleveland Rd

Site Category: (None)

Signals - EQUISAT (Fixed-Time/SCATS) Isolated Cycle Time = 140.0 seconds (Site User-Given Cycle Time)

Site Scenario: 1 | Local Volumes

Vehicle Movement Performance															
Mov ID	Turn	Mov Class	Demand Flows		Arrival Flows		Deg. Satn	Aver. Delay	Level of Service	95% Back Of Queue		Prop. Qued	Eff. Stop Rate	Number of Cycles to Depart	Aver. Speed
			[Total HV]	[Total HV]	[Total HV]	[Total HV]	v/c	sec		[Veh.]	[Dist]				km/h
			veh/h	%	veh/h	%				veh	m				
South: Tilley Rd_S															
1	L2	All MCs	122	1.0	122	1.0	0.072	10.9	LOS B	1.7	12.1	0.38	1.35	0.38	29.6
2	T1	All MCs	198	1.0	198	1.0	*0.777	70.7	LOS E	9.6	67.8	0.99	0.85	1.10	21.0
3	R2	All MCs	82	1.0	82	1.0	0.499	73.4	LOS E	5.5	39.1	1.00	0.77	1.00	22.7
Approach			402	1.0	402	1.0	0.777	53.1	LOS D	9.6	67.8	0.81	0.98	0.86	23.3
East: Old Cleveland Rd_E															
4	L2	All MCs	52	1.0	52	1.0	0.039	28.8	LOS C	0.4	2.5	0.19	0.99	0.19	37.7
5	T1	All MCs	1575	1.0	1575	1.0	*0.777	48.6	LOS D	36.6	258.1	0.91	0.81	0.91	38.8
6	R2	All MCs	100	1.0	100	1.0	0.355	81.6	LOS F	6.6	46.3	0.93	0.78	0.93	28.8
6u	U	All MCs	7	1.0	7	1.0	0.355	82.3	LOS F	6.6	46.3	0.93	0.78	0.93	30.2
Approach			1734	1.0	1734	1.0	0.777	50.1	LOS D	36.6	258.1	0.89	0.81	0.89	33.0
North: Tilley Rd_N															
7	L2	All MCs	43	1.0	43	1.0	0.059	20.2	LOS C	0.8	5.7	0.33	1.08	0.33	38.9
8	T1	All MCs	147	1.0	147	1.0	0.502	66.1	LOS E	9.3	65.3	0.95	0.78	0.95	24.0
9	R2	All MCs	402	1.0	402	1.0	*0.779	82.4	LOS F	14.0	99.1	1.00	0.90	1.11	24.3
Approach			593	1.0	593	1.0	0.779	73.8	LOS E	14.0	99.1	0.94	0.88	1.02	22.8
West: Old Cleveland Rd_W															
10	L2	All MCs	355	1.0	355	1.0	0.229	17.9	LOS B	1.9	13.1	0.14	0.81	0.14	45.4
11	T1	All MCs	1488	1.0	1488	1.0	0.774	48.4	LOS D	35.1	247.7	0.93	0.83	0.93	37.7
12	R2	All MCs	175	1.0	175	1.0	*0.777	92.5	LOS F	13.6	96.2	1.00	0.89	1.11	19.7
12u	U	All MCs	20	1.0	20	1.0	0.777	93.3	LOS F	13.6	96.2	1.00	0.89	1.11	23.0
Approach			2038	1.0	2038	1.0	0.777	47.3	LOS D	35.1	247.7	0.80	0.83	0.81	32.4
All Vehicles			4766	1.0	4766	1.0	0.779	52.1	LOS D	36.6	258.1	0.85	0.84	0.87	30.4

Site Level of Service (LOS) Method: Delay (SIDRA). Site LOS Method is specified in the Parameter Settings dialog (Options tab).

Vehicle movement LOS values are based on average delay per movement.

Intersection and Approach LOS values are based on average delay for all vehicle movements.

Delay Model: SIDRA Standard (Control Delay; Geometric Delay is included).

Queue Model: SIDRA queue estimation methods are used for Back of Queue and Queue at Start of Green.

Gap-Acceptance Capacity Formula: SIDRA Standard (Akçelik M3D).

HV (%) values are calculated for All Movement Classes of All Heavy Vehicle Model Designation.

Arrival Flows used in performance calculations are adjusted to include any Initial Queued Demand and Upstream Capacity Constraint effects.

* Critical Movement (Signal Timing)

Pedestrian Movement Performance											
Mov ID	Crossing	Input Vol.	Dem. Flow	Aver. Delay	Level of Service	AVERAGE BACK OF QUEUE	Prop. Qued	Eff. Stop	Travel Time	Travel Dist.	Aver. Speed

	ped/h	ped/h	sec		[Ped ped	Dist] m		Rate		sec	m	m/sec
West: Old Cleveland Rd_W												
P41 Stage 1	2	2	64.1	LOS F	0.0	0.0		0.96	0.96	218.0	200.0	0.92
P42 Stage 2	2	2	64.1	LOS F	0.0	0.0		0.96	0.96	218.0	200.0	0.92
All Pedestrians	4	4	64.1	LOS F	0.0	0.0		0.96	0.96	218.0	200.0	0.92

Level of Service (LOS) Method: SIDRA Pedestrian LOS Method (Based on Average Delay)

Pedestrian movement LOS values are based on average delay per pedestrian movement.

Intersection LOS value for Pedestrians is based on average delay for all pedestrian movements.

SIDRA INTERSECTION 10.0 | Copyright © 2000-2025 Akcelik and Associates Pty Ltd | sidrasolutions.com

Organisation: URBIS | Licence: NETWORK / 1PC | Processed: Thursday, 5 February 2026 12:34:18 PM

Project: C:\Users\bchui\OneDrive - Urbis Ltd\P0046052 577 Boston Road Chandler - General\09_Transport\01_Analysis\P0046052_Boston Rd_SIDRA_260106.sipx

MOVEMENT SUMMARY

Site: [2D270] Archer St/ Old Cleveland
 Rd_2027Dev_Outbound (2027 Dev_Outbound)

Output produced by SIDRA INTERSECTION Version: 10.0.5.217

Archer St/ Old Cleveland Rd
 Site Category: (None)
 Give-Way (Two-Way)
 Site Scenario: 1 | Local Volumes

Vehicle Movement Performance															
Mov ID	Turn	Mov Class	Demand Flows	Arrival Flows	Deg. Satn	Aver. Delay	Level of Service	95% Back Of Queue	Prop. Qued	Eff. Stop Rate	Number of Cycles to Depart	Aver. Speed			
			[Total HV]	[Total HV]	v/c	sec		[Veh.]	[Dist]			km/h			
			veh/h	%	veh/h	%		veh	m						
East: Old Cleveland Rd_E															
5	T1	All MCs	1667	1.0	1667	1.0	0.430	0.1	LOSA	0.0	0.0	0.00	0.00	0.00	69.7
Approach			1667	1.0	1667	1.0	0.430	0.1	NA	0.0	0.0	0.00	0.00	0.00	69.7
North: Archer St_N															
7	L2	All MCs	114	1.0	114	1.0	0.062	5.0	LOSA	0.0	0.0	0.00	0.52	0.00	50.3
Approach			114	1.0	114	1.0	0.062	5.0	NA	0.0	0.0	0.00	0.52	0.00	50.3
West: Old Cleveland Rd_E															
10	L2	All MCs	41	1.0	41	1.0	0.022	6.7	LOSA	0.0	0.0	0.00	0.57	0.00	54.0
11	T1	All MCs	1507	1.0	1507	1.0	0.389	0.1	LOSA	0.0	0.0	0.00	0.00	0.00	69.7
Approach			1548	1.0	1548	1.0	0.389	0.3	NA	0.0	0.0	0.00	0.02	0.00	69.4
All Vehicles			3329	1.0	3329	1.0	0.430	0.4	NA	0.0	0.0	0.00	0.02	0.00	69.0

Site Level of Service (LOS) Method: Delay (SIDRA). Site LOS Method is specified in the Parameter Settings dialog (Options tab).
 Vehicle movement LOS values are based on average delay per movement.
 Minor Road Approach LOS values are based on average delay for all vehicle movements.
 NA (TWSC): Level of Service is not defined for major road approaches or the intersection as a whole for Two-Way Sign Control (HCM LOS rule).
 Two-Way Sign Control Capacity Model: SIDRA Standard.
 Delay Model: SIDRA Standard (Control Delay: Geometric Delay is included).
 Queue Model: SIDRA queue estimation methods are used for Back of Queue and Queue at Start of Gap.
 Gap-Acceptance Capacity Formula: SIDRA Standard (Akçelik M3D).
 HV (%) values are calculated for All Movement Classes of All Heavy Vehicle Model Designation.
 Arrival Flows used in performance calculations are adjusted to include any Initial Queued Demand and Upstream Capacity Constraint effects.

MOVEMENT SUMMARY

Site: [3D270] Tilley Rd/ Boston Rd_2027Dev_Outbound
(2027 Dev_Outbound)

Output produced by SIDRA INTERSECTION Version: 10.0.5.217

Tilley Rd/ Boston Rd
Site Category: (None)
Give-Way (Two-Way)
Site Scenario: 1 | Local Volumes

Vehicle Movement Performance															
Mov ID	Turn	Mov Class	Demand Flows		Arrival Flows		Deg. Satn	Aver. Delay	Level of Service	95% Back Of Queue		Prop. Qued	Eff. Stop Rate	Number of Cycles to Depart	Aver. Speed
			[Total HV]	[Total HV]	[Total HV]	[Total HV]	v/c	sec		[Veh.]	[Dist]				km/h
			veh/h	%	veh/h	%				veh	m				
South: Tilley Road_S															
1	L2	All MCs	14	1.0	14	1.0	0.348	8.1	LOS A	0.2	1.4	0.04	0.06	0.04	60.4
2	T1	All MCs	631	1.0	631	1.0	0.348	0.1	LOS A	0.2	1.4	0.04	0.06	0.04	69.2
3	R2	All MCs	16	1.0	16	1.0	0.348	8.7	LOS A	0.2	1.4	0.04	0.06	0.04	60.0
Approach			660	1.0	660	1.0	0.348	0.5	NA	0.2	1.4	0.04	0.06	0.04	68.7
East: Boston Road_E															
4	L2	All MCs	105	1.0	105	1.0	0.283	8.2	LOS A	1.1	8.1	0.66	0.86	0.76	49.1
5	T1	All MCs	3	1.0	3	1.0	0.283	16.1	LOS C	1.1	8.1	0.66	0.86	0.76	48.8
6	R2	All MCs	43	1.0	43	1.0	0.283	20.5	LOS C	1.1	8.1	0.66	0.86	0.76	49.2
Approach			152	1.0	152	1.0	0.283	11.9	LOS B	1.1	8.1	0.66	0.86	0.76	49.2
North: Tilley Road_N															
7	L2	All MCs	5	1.0	5	1.0	0.262	8.8	LOS A	0.1	0.8	0.03	0.04	0.03	60.7
8	T1	All MCs	488	1.0	488	1.0	0.262	0.1	LOS A	0.1	0.8	0.03	0.04	0.03	69.5
9	R2	All MCs	6	1.0	6	1.0	0.262	9.6	LOS A	0.1	0.8	0.03	0.04	0.03	60.3
Approach			500	1.0	500	1.0	0.262	0.3	NA	0.1	0.8	0.03	0.04	0.03	69.2
West: Boston Road_W															
10	L2	All MCs	1	1.0	1	1.0	0.088	8.3	LOS A	0.3	1.9	0.78	0.90	0.78	46.6
11	T1	All MCs	15	1.0	15	1.0	0.088	13.8	LOS B	0.3	1.9	0.78	0.90	0.78	46.3
12	R2	All MCs	9	1.0	9	1.0	0.088	19.9	LOS C	0.3	1.9	0.78	0.90	0.78	46.2
Approach			25	1.0	25	1.0	0.088	15.9	LOS C	0.3	1.9	0.78	0.90	0.78	46.2
All Vehicles			1337	1.0	1337	1.0	0.348	2.0	NA	1.1	8.1	0.12	0.16	0.13	65.0

Site Level of Service (LOS) Method: Delay (SIDRA). Site LOS Method is specified in the Parameter Settings dialog (Options tab).
 Vehicle movement LOS values are based on average delay per movement.
 Minor Road Approach LOS values are based on average delay for all vehicle movements.
 NA (TWSC): Level of Service is not defined for major road approaches or the intersection as a whole for Two-Way Sign Control (HCM LOS rule).
 Two-Way Sign Control Capacity Model: SIDRA Standard.
 Delay Model: SIDRA Standard (Control Delay: Geometric Delay is included).
 Queue Model: SIDRA queue estimation methods are used for Back of Queue and Queue at Start of Gap.
 Gap-Acceptance Capacity Formula: SIDRA Standard (Akçelik M3D).
 HV (%) values are calculated for All Movement Classes of All Heavy Vehicle Model Designation.
 Arrival Flows used in performance calculations are adjusted to include any Initial Queued Demand and Upstream Capacity Constraint effects.

MOVEMENT SUMMARY

Site: [4D270] Boston Rd/ Archer St_202Dev_Outbound (2027 Dev_Outbound)

Output produced by SIDRA INTERSECTION Version: 10.0.5.217

Boston Rd/ Archer St
 Site Category: (None)
 Give-Way (Two-Way)
 Site Scenario: 1 | Local Volumes

Vehicle Movement Performance															
Mov ID	Turn	Mov Class	Demand Flows		Arrival Flows		Deg. Satn	Aver. Delay	Level of Service	95% Back Of Queue		Prop. Qued	Eff. Stop of Cycles	Number of Cycles	Aver. Speed
			[Total HV]	%	[Total HV]	%	v/c	sec		[Veh.]	[Dist]		Rate to Depart		km/h
			veh/h		veh/h					veh	m				
South: Archer Street_S															
1	L2	All MCs	1	1.0	1	1.0	0.024	5.2	LOS A	0.0	0.3	0.07	0.11	0.07	54.2
2	T1	All MCs	38	1.0	38	1.0	0.024	0.1	LOS A	0.0	0.3	0.07	0.11	0.07	57.9
3	R2	All MCs	6	1.0	6	1.0	0.024	5.1	LOS A	0.0	0.3	0.07	0.11	0.07	53.7
Approach			45	1.0	45	1.0	0.024	0.9	NA	0.0	0.3	0.07	0.11	0.07	57.1
East: Boston Road_E															
4	L2	All MCs	1	1.0	1	1.0	0.022	5.8	LOS A	0.1	0.5	0.23	0.54	0.23	48.7
5	T1	All MCs	14	1.0	14	1.0	0.022	4.7	LOS A	0.1	0.5	0.23	0.54	0.23	53.2
6	R2	All MCs	9	1.0	9	1.0	0.022	6.2	LOS A	0.1	0.5	0.23	0.54	0.23	51.8
Approach			24	1.0	24	1.0	0.022	5.3	LOS A	0.1	0.5	0.23	0.54	0.23	52.6
North: Archer Street_N															
7	L2	All MCs	16	1.0	16	1.0	0.056	5.6	LOS A	0.1	0.6	0.04	0.16	0.04	55.6
8	T1	All MCs	78	1.0	78	1.0	0.056	0.0	LOS A	0.1	0.6	0.04	0.16	0.04	56.9
9	R2	All MCs	12	1.0	12	1.0	0.056	5.5	LOS A	0.1	0.6	0.04	0.16	0.04	55.3
Approach			105	1.0	105	1.0	0.056	1.5	NA	0.1	0.6	0.04	0.16	0.04	56.3
West: Boston Road_W															
10	L2	All MCs	7	1.0	7	1.0	0.065	5.7	LOS A	0.2	1.6	0.22	0.57	0.22	51.7
11	T1	All MCs	9	1.0	9	1.0	0.065	4.7	LOS A	0.2	1.6	0.22	0.57	0.22	52.9
12	R2	All MCs	51	1.0	51	1.0	0.065	6.2	LOS A	0.2	1.6	0.22	0.57	0.22	47.7
Approach			67	1.0	67	1.0	0.065	5.9	LOS A	0.2	1.6	0.22	0.57	0.22	49.3
All Vehicles			242	1.0	242	1.0	0.065	3.0	NA	0.2	1.6	0.11	0.30	0.11	53.6

Site Level of Service (LOS) Method: Delay (SIDRA). Site LOS Method is specified in the Parameter Settings dialog (Options tab).
 Vehicle movement LOS values are based on average delay per movement.
 Minor Road Approach LOS values are based on average delay for all vehicle movements.
 NA (TWSC): Level of Service is not defined for major road approaches or the intersection as a whole for Two-Way Sign Control (HCM LOS rule).
 Two-Way Sign Control Capacity Model: SIDRA Standard.
 Delay Model: SIDRA Standard (Control Delay: Geometric Delay is included).
 Queue Model: SIDRA queue estimation methods are used for Back of Queue and Queue at Start of Gap.
 Gap-Acceptance Capacity Formula: SIDRA Standard (Akçelik M3D).
 HV (%) values are calculated for All Movement Classes of All Heavy Vehicle Model Designation.
 Arrival Flows used in performance calculations are adjusted to include any Initial Queued Demand and Upstream Capacity Constraint effects.

MOVEMENT SUMMARY

Site: [5D270] Boston Rd/ Site Access_2027Dev_Outbound
(2027 Dev_Outbound)

Output produced by SIDRA INTERSECTION Version: 10.0.5.217

Boston Rd/ Site Access

Site Category: (None)

Give-Way (Two-Way)

Site Scenario: 1 | Local Volumes

Vehicle Movement Performance															
Mov ID	Turn	Mov Class	Demand Flows		Arrival Flows		Deg. Satn	Aver. Delay	Level of Service	95% Back Of Queue		Prop. Qued	Eff. Stop of Cycles	Number of Cycles to Depart	Aver. Speed
			[Total HV]	[Total HV]	[Total HV]	[Total HV]	v/c	sec		[Veh.]	[Dist]		Rate		km/h
			veh/h	%	veh/h	%				veh	m				
South: Site Access_S															
1	L2	All MCs	120	1.0	120	1.0	0.108	1.9	LOS A	0.4	3.1	0.10	0.41	0.10	51.1
3	R2	All MCs	40	1.0	40	1.0	0.108	2.0	LOS A	0.4	3.1	0.10	0.41	0.10	50.6
Approach			160	1.0	160	1.0	0.108	1.9	LOS A	0.4	3.1	0.10	0.41	0.10	51.0
East: Boston Road_E															
4	L2	All MCs	1	1.0	1	1.0	0.015	5.6	LOS A	0.0	0.0	0.00	0.02	0.00	57.9
5	T1	All MCs	27	1.0	27	1.0	0.015	0.0	LOS A	0.0	0.0	0.00	0.02	0.00	59.8
Approach			28	1.0	28	1.0	0.015	0.2	NA	0.0	0.0	0.00	0.02	0.00	59.8
West: Boston Road_W															
11	T1	All MCs	37	1.0	37	1.0	0.020	0.0	LOS A	0.0	0.0	0.01	0.02	0.01	59.8
12	R2	All MCs	1	1.0	1	1.0	0.020	5.5	LOS A	0.0	0.0	0.01	0.02	0.01	57.6
Approach			38	1.0	38	1.0	0.020	0.2	NA	0.0	0.0	0.01	0.02	0.01	59.8
All Vehicles			226	1.0	226	1.0	0.108	1.4	NA	0.4	3.1	0.07	0.30	0.07	54.5

Site Level of Service (LOS) Method: Delay (SIDRA). Site LOS Method is specified in the Parameter Settings dialog (Options tab).

Vehicle movement LOS values are based on average delay per movement.

Minor Road Approach LOS values are based on average delay for all vehicle movements.

NA (TWSC): Level of Service is not defined for major road approaches or the intersection as a whole for Two-Way Sign Control (HCM LOS rule).

Two-Way Sign Control Capacity Model: SIDRA Standard.

Delay Model: SIDRA Standard (Control Delay: Geometric Delay is included).

Queue Model: SIDRA queue estimation methods are used for Back of Queue and Queue at Start of Gap.

Gap-Acceptance Capacity Formula: SIDRA Standard (Akçelik M3D).

HV (%) values are calculated for All Movement Classes of All Heavy Vehicle Model Designation.

Arrival Flows used in performance calculations are adjusted to include any Initial Queued Demand and Upstream Capacity Constraint effects.

SIDRA INTERSECTION 10.0 | Copyright © 2000-2025 Akcelik and Associates Pty Ltd | sidrasolutions.com

Organisation: URBIS | Licence: NETWORK / 1PC | Processed: Tuesday, 3 February 2026 5:00:18 PM

Project: C:\Users\lbchui\OneDrive - Urbis Ltd\P0046052 577 Boston Road Chandler - General\09_Transport\01_Analysis\P0046052_Boston Rd_SIDRA_260106.sipx

MOVEMENT SUMMARY

Site: [5BG37I] Boston Rd/ Site Access_2037BG_Inbound
(2037 BG Inbound)

Output produced by SIDRA INTERSECTION Version: 10.0.5.217

Boston Rd/ Site Access

Site Category: (None)

Give-Way (Two-Way)

Site Scenario: 1 | Local Volumes

Vehicle Movement Performance															
Mov ID	Turn	Mov Class	Demand Flows		Arrival Flows		Deg. Satn	Aver. Delay	Level of Service	95% Back Of Queue		Prop. Qued	Eff. Stop of Cycles	Number of Cycles to Depart	Aver. Speed
			[Total HV]	[Total HV]	[Total HV]	[Total HV]	v/c	sec		[Veh.]	[Dist]		Rate	Rate	km/h
			veh/h	%	veh/h	%				veh	m				
South: Site Access_S															
1	L2	All MCs	1	1.0	1	1.0	0.002	1.9	LOSA	0.0	0.0	0.11	0.41	0.11	51.1
3	R2	All MCs	1	1.0	1	1.0	0.002	2.0	LOSA	0.0	0.0	0.11	0.41	0.11	50.6
Approach			2	1.0	2	1.0	0.002	2.0	LOSA	0.0	0.0	0.11	0.41	0.11	50.9
East: Boston Road_E															
4	L2	All MCs	1	1.0	1	1.0	0.016	5.6	LOSA	0.0	0.0	0.00	0.02	0.00	58.0
5	T1	All MCs	29	1.0	29	1.0	0.016	0.0	LOSA	0.0	0.0	0.00	0.02	0.00	59.8
Approach			31	1.0	31	1.0	0.016	0.2	NA	0.0	0.0	0.00	0.02	0.00	59.8
West: Boston Road_W															
11	T1	All MCs	39	1.0	39	1.0	0.036	0.1	LOSA	0.1	0.9	0.08	0.25	0.08	57.6
12	R2	All MCs	27	1.0	27	1.0	0.036	5.5	LOSA	0.1	0.9	0.08	0.25	0.08	53.7
Approach			66	1.0	66	1.0	0.036	2.3	NA	0.1	0.9	0.08	0.25	0.08	56.5
All Vehicles			99	1.0	99	1.0	0.036	1.7	NA	0.1	0.9	0.05	0.18	0.05	57.5

Site Level of Service (LOS) Method: Delay (SIDRA). Site LOS Method is specified in the Parameter Settings dialog (Options tab).

Vehicle movement LOS values are based on average delay per movement.

Minor Road Approach LOS values are based on average delay for all vehicle movements.

NA (TWSC): Level of Service is not defined for major road approaches or the intersection as a whole for Two-Way Sign Control (HCM LOS rule).

Two-Way Sign Control Capacity Model: SIDRA Standard.

Delay Model: SIDRA Standard (Control Delay: Geometric Delay is included).

Queue Model: SIDRA queue estimation methods are used for Back of Queue and Queue at Start of Gap.

Gap-Acceptance Capacity Formula: SIDRA Standard (Akçelik M3D).

HV (%) values are calculated for All Movement Classes of All Heavy Vehicle Model Designation.

Arrival Flows used in performance calculations are adjusted to include any Initial Queued Demand and Upstream Capacity Constraint effects.

SIDRA INTERSECTION 10.0 | Copyright © 2000-2025 Akcelik and Associates Pty Ltd | sidrasolutions.com

Organisation: URBIS | Licence: NETWORK / 1PC | Processed: Tuesday, 3 February 2026 5:00:20 PM

Project: C:\Users\lbchui\OneDrive - Urbis Ltd\P0046052 577 Boston Road Chandler - General\09_Transport\01_Analysis\P0046052_Boston Rd_SIDRA_260106.sipx

MOVEMENT SUMMARY

Site: [1BG37I] Tilley Rd/ Old Cleveland Rd_2037BG_Inbound
(2037 BG Inbound)

Output produced by SIDRA INTERSECTION Version: 10.0.5.217

Tilley Rd/ Old Cleveland Rd

Site Category: (None)

Signals - EQUISAT (Fixed-Time/SCATS) Isolated Cycle Time = 140.0 seconds (Site User-Given Cycle Time)

Site Scenario: 1 | Local Volumes

Vehicle Movement Performance															
Mov ID	Turn	Mov Class	Demand Flows		Arrival Flows		Deg. Satn	Aver. Delay	Level of Service	95% Back Of Queue		Prop. Qued	Eff. Stop Rate	Number of Cycles to Depart	Aver. Speed
			[Total HV]	%	[Total HV]	%	v/c	sec		[Veh.]	[Dist]				km/h
			veh/h		veh/h					veh	m				
South: Tilley Rd_S															
1	L2	All MCs	128	1.0	128	1.0	0.077	9.0	LOS A	1.3	9.5	0.31	1.23	0.31	33.0
2	T1	All MCs	207	1.0	207	1.0	*0.775	70.0	LOS E	10.0	70.8	0.99	0.85	1.09	21.1
3	R2	All MCs	86	1.0	86	1.0	0.499	72.8	LOS E	5.8	40.9	0.99	0.78	0.99	22.8
Approach			422	1.0	422	1.0	0.775	52.0	LOS D	10.0	70.8	0.78	0.95	0.83	23.9
East: Old Cleveland Rd_E															
4	L2	All MCs	55	1.0	55	1.0	0.042	28.8	LOS C	0.5	3.8	0.27	1.12	0.27	35.9
5	T1	All MCs	1653	1.0	1653	1.0	*0.775	45.9	LOS D	37.9	267.6	0.89	0.80	0.89	39.9
6	R2	All MCs	112	1.0	112	1.0	0.372	79.9	LOS E	7.2	51.0	0.93	0.79	0.93	29.1
6u	U	All MCs	7	1.0	7	1.0	0.372	80.7	LOS F	7.2	51.0	0.93	0.79	0.93	30.5
Approach			1826	1.0	1826	1.0	0.775	47.6	LOS D	37.9	267.6	0.87	0.81	0.87	33.9
North: Tilley Rd_N															
7	L2	All MCs	45	1.0	45	1.0	0.059	25.1	LOS C	1.0	7.3	0.40	1.09	0.40	38.9
8	T1	All MCs	155	1.0	155	1.0	*0.742	79.1	LOS E	12.1	85.7	1.00	0.88	1.11	21.5
9	R2	All MCs	338	1.0	338	1.0	0.742	76.7	LOS E	12.1	85.7	1.00	0.87	1.09	24.3
Approach			538	1.0	538	1.0	0.742	73.1	LOS E	12.1	85.7	0.95	0.89	1.03	22.8
West: Old Cleveland Rd_W															
10	L2	All MCs	386	1.0	386	1.0	0.266	17.4	LOS B	2.1	15.0	0.15	0.84	0.15	44.4
11	T1	All MCs	1562	1.0	1562	1.0	0.775	45.3	LOS D	36.1	254.6	0.92	0.82	0.92	38.3
12	R2	All MCs	183	1.0	183	1.0	*0.775	87.1	LOS F	14.2	100.3	1.00	0.89	1.10	19.8
12u	U	All MCs	21	1.0	21	1.0	0.775	87.9	LOS F	14.2	100.3	1.00	0.89	1.10	23.1
Approach			2153	1.0	2153	1.0	0.775	44.3	LOS D	36.1	254.6	0.79	0.83	0.80	33.4
All Vehicles			4939	1.0	4939	1.0	0.775	49.3	LOS D	37.9	267.6	0.84	0.84	0.86	31.3

Site Level of Service (LOS) Method: Delay (SIDRA). Site LOS Method is specified in the Parameter Settings dialog (Options tab).

Vehicle movement LOS values are based on average delay per movement.

Intersection and Approach LOS values are based on average delay for all vehicle movements.

Delay Model: SIDRA Standard (Control Delay; Geometric Delay is included).

Queue Model: SIDRA queue estimation methods are used for Back of Queue and Queue at Start of Green.

Gap-Acceptance Capacity Formula: SIDRA Standard (Akçelik M3D).

HV (%) values are calculated for All Movement Classes of All Heavy Vehicle Model Designation.

Arrival Flows used in performance calculations are adjusted to include any Initial Queued Demand and Upstream Capacity Constraint effects.

* Critical Movement (Signal Timing)

Pedestrian Movement Performance											
Mov ID	Crossing	Input Vol.	Dem. Flow	Aver. Delay	Level of Service	AVERAGE BACK OF QUEUE	Prop. Qued	Eff. Stop	Travel Time	Travel Dist.	Aver. Speed

	ped/h	ped/h	sec		[Ped ped	Dist] m		Rate		sec	m	m/sec
West: Old Cleveland Rd_W												
P41 Stage 1	2	2	64.1	LOS F	0.0	0.0		0.96	0.96	218.0	200.0	0.92
P42 Stage 2	2	2	64.1	LOS F	0.0	0.0		0.96	0.96	218.0	200.0	0.92
All Pedestrians	4	4	64.1	LOS F	0.0	0.0		0.96	0.96	218.0	200.0	0.92

Level of Service (LOS) Method: SIDRA Pedestrian LOS Method (Based on Average Delay)

Pedestrian movement LOS values are based on average delay per pedestrian movement.

Intersection LOS value for Pedestrians is based on average delay for all pedestrian movements.

SIDRA INTERSECTION 10.0 | Copyright © 2000-2025 Akcelik and Associates Pty Ltd | sidrasolutions.com

Organisation: URBIS | Licence: NETWORK / 1PC | Processed: Tuesday, 3 February 2026 5:00:18 PM

Project: C:\Users\bchui\OneDrive - Urbis Ltd\P0046052 577 Boston Road Chandler - General\09_Transport\01_Analysis\P0046052_Boston Rd_SIDRA_260106.sipx

MOVEMENT SUMMARY

Site: [2BG37I] Archer St/ Old Cleveland Rd_2037BG_Inbound
(2037 BG Inbound)

Output produced by SIDRA INTERSECTION Version: 10.0.5.217

Archer St/ Old Cleveland Rd

Site Category: (None)

Give-Way (Two-Way)

Site Scenario: 1 | Local Volumes

Vehicle Movement Performance															
Mov ID	Turn	Mov Class	Demand Flows	Arrival Flows	Deg. Satn	Aver. Delay	Level of Service	95% Back Of Queue	Prop. Qued	Eff. Stop Rate	Number of Cycles to Depart	Aver. Speed			
			[Total HV]	[Total HV]	v/c	sec		[Veh.]	[Dist]			km/h			
			veh/h	%	veh/h	%		veh	m						
East: Old Cleveland Rd_E															
5	T1	All MCs	1757	1.0	1757	1.0	0.453	0.1	LOSA	0.0	0.0	0.00	0.00	0.00	69.6
Approach			1757	1.0	1757	1.0	0.453	0.1	NA	0.0	0.0	0.00	0.00	0.00	69.6
North: Archer St_N															
7	L2	All MCs	77	1.0	77	1.0	0.042	5.0	LOSA	0.0	0.0	0.00	0.52	0.00	50.3
Approach			77	1.0	77	1.0	0.042	5.0	NA	0.0	0.0	0.00	0.52	0.00	50.3
West: Old Cleveland Rd_E															
10	L2	All MCs	43	1.0	43	1.0	0.023	6.7	LOSA	0.0	0.0	0.00	0.57	0.00	54.0
11	T1	All MCs	1582	1.0	1582	1.0	0.408	0.1	LOSA	0.0	0.0	0.00	0.00	0.00	69.7
Approach			1625	1.0	1625	1.0	0.408	0.3	NA	0.0	0.0	0.00	0.02	0.00	69.4
All Vehicles			3459	1.0	3459	1.0	0.453	0.3	NA	0.0	0.0	0.00	0.02	0.00	69.1

Site Level of Service (LOS) Method: Delay (SIDRA). Site LOS Method is specified in the Parameter Settings dialog (Options tab).

Vehicle movement LOS values are based on average delay per movement.

Minor Road Approach LOS values are based on average delay for all vehicle movements.

NA (TWSC): Level of Service is not defined for major road approaches or the intersection as a whole for Two-Way Sign Control (HCM LOS rule).

Two-Way Sign Control Capacity Model: SIDRA Standard.

Delay Model: SIDRA Standard (Control Delay: Geometric Delay is included).

Queue Model: SIDRA queue estimation methods are used for Back of Queue and Queue at Start of Gap.

Gap-Acceptance Capacity Formula: SIDRA Standard (Akçelik M3D).

HV (%) values are calculated for All Movement Classes of All Heavy Vehicle Model Designation.

Arrival Flows used in performance calculations are adjusted to include any Initial Queued Demand and Upstream Capacity Constraint effects.

SIDRA INTERSECTION 10.0 | Copyright © 2000-2025 Akcelik and Associates Pty Ltd | sidrasolutions.com

Organisation: URBIS | Licence: NETWORK / 1PC | Processed: Tuesday, 3 February 2026 5:00:19 PM

Project: C:\Users\bchui\OneDrive - Urbis Ltd\P0046052 577 Boston Road Chandler - General\09_Transport\01_Analysis\P0046052_Boston Rd_SIDRA_260106.sipx

MOVEMENT SUMMARY

Site: [3BG37I] Tilley Rd/ Boston Rd_2037BG_Inbound (2037 BG Inbound)

Output produced by SIDRA INTERSECTION Version: 10.0.5.217

Tilley Rd/ Boston Rd
 Site Category: (None)
 Give-Way (Two-Way)
 Site Scenario: 1 | Local Volumes

Vehicle Movement Performance															
Mov ID	Turn	Mov Class	Demand Flows		Arrival Flows		Deg. Satn	Aver. Delay	Level of Service	95% Back Of Queue		Prop. Qued	Eff. Stop of Cycles	Number of Cycles	Aver. Speed
			[Total HV]	[Total HV]	[Total HV]	[Total HV]	v/c	sec		[Veh.]	[Dist]		Rate to Depart		km/h
			veh/h	%	veh/h	%				veh	m				
South: Tilley Road_S															
1	L2	All MCs	15	1.0	15	1.0	0.386	8.8	LOS A	0.5	3.6	0.08	0.12	0.09	59.9
2	T1	All MCs	662	1.0	662	1.0	0.386	0.3	LOS A	0.5	3.6	0.08	0.12	0.09	68.5
3	R2	All MCs	37	1.0	37	1.0	0.386	9.0	LOS A	0.5	3.6	0.08	0.12	0.09	59.5
Approach			714	1.0	714	1.0	0.386	0.9	NA	0.5	3.6	0.08	0.12	0.09	67.7
East: Boston Road_E															
4	L2	All MCs	26	1.0	26	1.0	0.052	7.6	LOS A	0.2	1.3	0.58	0.73	0.58	50.9
5	T1	All MCs	3	1.0	3	1.0	0.052	15.8	LOS C	0.2	1.3	0.58	0.73	0.58	50.3
6	R2	All MCs	3	1.0	3	1.0	0.052	20.2	LOS C	0.2	1.3	0.58	0.73	0.58	50.9
Approach			33	1.0	33	1.0	0.052	9.6	LOS A	0.2	1.3	0.58	0.73	0.58	50.8
North: Tilley Road_N															
7	L2	All MCs	13	1.0	13	1.0	0.279	8.2	LOS A	0.1	0.9	0.03	0.05	0.03	60.6
8	T1	All MCs	513	1.0	513	1.0	0.279	0.1	LOS A	0.1	0.9	0.03	0.05	0.03	69.3
9	R2	All MCs	6	1.0	6	1.0	0.279	9.9	LOS A	0.1	0.9	0.03	0.05	0.03	60.2
Approach			532	1.0	532	1.0	0.279	0.4	NA	0.1	0.9	0.03	0.05	0.03	68.9
West: Boston Road_W															
10	L2	All MCs	1	1.0	1	1.0	0.105	8.5	LOS A	0.3	2.3	0.80	0.91	0.80	45.7
11	T1	All MCs	16	1.0	16	1.0	0.105	15.7	LOS C	0.3	2.3	0.80	0.91	0.80	45.5
12	R2	All MCs	11	1.0	11	1.0	0.105	20.5	LOS C	0.3	2.3	0.80	0.91	0.80	45.3
Approach			27	1.0	27	1.0	0.105	17.3	LOS C	0.3	2.3	0.80	0.91	0.80	45.4
All Vehicles			1305	1.0	1305	1.0	0.386	1.3	NA	0.5	3.6	0.09	0.12	0.09	66.8

Site Level of Service (LOS) Method: Delay (SIDRA). Site LOS Method is specified in the Parameter Settings dialog (Options tab).
 Vehicle movement LOS values are based on average delay per movement.
 Minor Road Approach LOS values are based on average delay for all vehicle movements.
 NA (TWSC): Level of Service is not defined for major road approaches or the intersection as a whole for Two-Way Sign Control (HCM LOS rule).
 Two-Way Sign Control Capacity Model: SIDRA Standard.
 Delay Model: SIDRA Standard (Control Delay: Geometric Delay is included).
 Queue Model: SIDRA queue estimation methods are used for Back of Queue and Queue at Start of Gap.
 Gap-Acceptance Capacity Formula: SIDRA Standard (Akçelik M3D).
 HV (%) values are calculated for All Movement Classes of All Heavy Vehicle Model Designation.
 Arrival Flows used in performance calculations are adjusted to include any Initial Queued Demand and Upstream Capacity Constraint effects.

MOVEMENT SUMMARY

Site: [4BG37I] Boston Rd/ Archer St_2037BG_Inbound (2037 BG Inbound)

Output produced by SIDRA INTERSECTION Version: 10.0.5.217

Boston Rd/ Archer St
 Site Category: (None)
 Give-Way (Two-Way)
 Site Scenario: 1 | Local Volumes

Vehicle Movement Performance																
Mov ID	Turn	Mov Class	Demand Flows		Arrival Flows		Deg. Satn	Aver. Delay	Level of Service	95% Back Of Queue		Prop. Qued	Eff. Stop of Cycles	Number of Cycles	Aver. Speed	
			[Total HV]	[Total HV]	[Total HV]		v/c	sec	[Veh. Dist]				Rate to Depart	km/h		
			veh/h	%	veh/h	%			veh	m						
South: Archer Street_S																
1	L2	All MCs	1	1.0	1	1.0	0.025	5.2	LOS A	0.0	0.3	0.06	0.11	0.06	54.3	
2	T1	All MCs	40	1.0	40	1.0	0.025	0.1	LOS A	0.0	0.3	0.06	0.11	0.06	58.0	
3	R2	All MCs	6	1.0	6	1.0	0.025	5.2	LOS A	0.0	0.3	0.06	0.11	0.06	53.8	
Approach			47	1.0	47	1.0	0.025	0.8	NA	0.0	0.3	0.06	0.11	0.06	57.2	
East: Boston Road_E																
4	L2	All MCs	1	1.0	1	1.0	0.025	5.8	LOS A	0.1	0.6	0.24	0.54	0.24	48.6	
5	T1	All MCs	15	1.0	15	1.0	0.025	4.7	LOS A	0.1	0.6	0.24	0.54	0.24	53.2	
6	R2	All MCs	11	1.0	11	1.0	0.025	6.2	LOS A	0.1	0.6	0.24	0.54	0.24	51.8	
Approach			26	1.0	26	1.0	0.025	5.3	LOS A	0.1	0.6	0.24	0.54	0.24	52.5	
North: Archer Street_N																
7	L2	All MCs	17	1.0	17	1.0	0.059	5.6	LOS A	0.1	0.7	0.04	0.16	0.04	55.6	
8	T1	All MCs	81	1.0	81	1.0	0.059	0.0	LOS A	0.1	0.7	0.04	0.16	0.04	56.8	
9	R2	All MCs	13	1.0	13	1.0	0.059	5.5	LOS A	0.1	0.7	0.04	0.16	0.04	55.3	
Approach			111	1.0	111	1.0	0.059	1.5	NA	0.1	0.7	0.04	0.16	0.04	56.3	
West: Boston Road_W																
10	L2	All MCs	7	1.0	7	1.0	0.026	5.7	LOS A	0.1	0.6	0.19	0.54	0.19	52.0	
11	T1	All MCs	11	1.0	11	1.0	0.026	4.7	LOS A	0.1	0.6	0.19	0.54	0.19	53.1	
12	R2	All MCs	12	1.0	12	1.0	0.026	6.2	LOS A	0.1	0.6	0.19	0.54	0.19	48.1	
Approach			29	1.0	29	1.0	0.026	5.5	LOS A	0.1	0.6	0.19	0.54	0.19	51.3	
All Vehicles			214	1.0	214	1.0	0.059	2.4	NA	0.1	0.7	0.09	0.25	0.09	54.8	

Site Level of Service (LOS) Method: Delay (SIDRA). Site LOS Method is specified in the Parameter Settings dialog (Options tab).
 Vehicle movement LOS values are based on average delay per movement.
 Minor Road Approach LOS values are based on average delay for all vehicle movements.
 NA (TWSC): Level of Service is not defined for major road approaches or the intersection as a whole for Two-Way Sign Control (HCM LOS rule).
 Two-Way Sign Control Capacity Model: SIDRA Standard.
 Delay Model: SIDRA Standard (Control Delay: Geometric Delay is included).
 Queue Model: SIDRA queue estimation methods are used for Back of Queue and Queue at Start of Gap.
 Gap-Acceptance Capacity Formula: SIDRA Standard (Akçelik M3D).
 HV (%) values are calculated for All Movement Classes of All Heavy Vehicle Model Designation.
 Arrival Flows used in performance calculations are adjusted to include any Initial Queued Demand and Upstream Capacity Constraint effects.

MOVEMENT SUMMARY

Site: [5BG370] Boston Rd/ Site Access_2037BG_Outbound
(2037 BG Outbound)

Output produced by SIDRA INTERSECTION Version: 10.0.5.217

Boston Rd/ Site Access

Site Category: (None)

Give-Way (Two-Way)

Site Scenario: 1 | Local Volumes

Vehicle Movement Performance															
Mov ID	Turn	Mov Class	Demand Flows		Arrival Flows		Deg. Satn	Aver. Delay	Level of Service	95% Back Of Queue		Prop. Qued	Eff. Stop of Cycles	Number of Cycles to Depart	Aver. Speed
			[Total HV]	[Total HV]	[Total HV]	[Total HV]	v/c	sec		[Veh.]	[Dist]		Rate		km/h
			veh/h	%	veh/h	%				veh	m				
South: Site Access_S															
1	L2	All MCs	42	1.0	42	1.0	0.039	1.9	LOS A	0.1	1.0	0.10	0.41	0.10	51.1
3	R2	All MCs	15	1.0	15	1.0	0.039	2.0	LOS A	0.1	1.0	0.10	0.41	0.10	50.6
Approach			57	1.0	57	1.0	0.039	1.9	LOS A	0.1	1.0	0.10	0.41	0.10	51.0
East: Boston Road_E															
4	L2	All MCs	1	1.0	1	1.0	0.016	5.6	LOS A	0.0	0.0	0.00	0.02	0.00	58.0
5	T1	All MCs	29	1.0	29	1.0	0.016	0.0	LOS A	0.0	0.0	0.00	0.02	0.00	59.8
Approach			31	1.0	31	1.0	0.016	0.2	NA	0.0	0.0	0.00	0.02	0.00	59.8
West: Boston Road_W															
11	T1	All MCs	39	1.0	39	1.0	0.021	0.0	LOS A	0.0	0.0	0.01	0.02	0.01	59.8
12	R2	All MCs	1	1.0	1	1.0	0.021	5.5	LOS A	0.0	0.0	0.01	0.02	0.01	57.7
Approach			40	1.0	40	1.0	0.021	0.1	NA	0.0	0.0	0.01	0.02	0.01	59.8
All Vehicles			127	1.0	127	1.0	0.039	1.0	NA	0.1	1.0	0.05	0.19	0.05	56.9

Site Level of Service (LOS) Method: Delay (SIDRA). Site LOS Method is specified in the Parameter Settings dialog (Options tab).

Vehicle movement LOS values are based on average delay per movement.

Minor Road Approach LOS values are based on average delay for all vehicle movements.

NA (TWSC): Level of Service is not defined for major road approaches or the intersection as a whole for Two-Way Sign Control (HCM LOS rule).

Two-Way Sign Control Capacity Model: SIDRA Standard.

Delay Model: SIDRA Standard (Control Delay: Geometric Delay is included).

Queue Model: SIDRA queue estimation methods are used for Back of Queue and Queue at Start of Gap.

Gap-Acceptance Capacity Formula: SIDRA Standard (Akçelik M3D).

HV (%) values are calculated for All Movement Classes of All Heavy Vehicle Model Designation.

Arrival Flows used in performance calculations are adjusted to include any Initial Queued Demand and Upstream Capacity Constraint effects.

SIDRA INTERSECTION 10.0 | Copyright © 2000-2025 Akcelik and Associates Pty Ltd | sidrasolutions.com

Organisation: URBIS | Licence: NETWORK / 1PC | Processed: Tuesday, 3 February 2026 5:00:22 PM

Project: C:\Users\lbchui\OneDrive - Urbis Ltd\P0046052 577 Boston Road Chandler - General\09_Transport\01_Analysis\P0046052_Boston Rd_SIDRA_260106.sipx

MOVEMENT SUMMARY

 Site: [1BG370] Tilley Rd/ Old Cleveland Rd_2037BG_Outbound (2037 BG Outbound)

Output produced by SIDRA INTERSECTION Version: 10.0.5.217

Tilley Rd/ Old Cleveland Rd

Site Category: (None)

Signals - EQUISAT (Fixed-Time/SCATS) Isolated Cycle Time = 140.0 seconds (Site User-Given Cycle Time)

Site Scenario: 1 | Local Volumes

Vehicle Movement Performance															
Mov ID	Turn	Mov Class	Demand Flows		Arrival Flows		Deg. Satn	Aver. Delay	Level of Service	95% Back Of Queue		Prop. Qued	Eff. Stop Rate	Number of Cycles to Depart	Aver. Speed
			[Total HV]	%	[Total HV]	%	v/c	sec		[Veh.]	[Dist]				km/h
			veh/h		veh/h					veh	m				
South: Tilley Rd_S															
1	L2	All MCs	128	1.0	128	1.0	0.075	9.0	LOS A	1.3	9.4	0.30	1.23	0.30	32.8
2	T1	All MCs	207	1.0	207	1.0	*0.778	70.2	LOS E	10.0	70.9	0.99	0.85	1.09	21.1
3	R2	All MCs	86	1.0	86	1.0	0.502	72.9	LOS E	5.8	41.0	0.99	0.78	0.99	22.8
Approach			422	1.0	422	1.0	0.778	52.1	LOS D	10.0	70.9	0.78	0.95	0.83	23.9
East: Old Cleveland Rd_E															
4	L2	All MCs	55	1.0	55	1.0	0.042	28.9	LOS C	0.5	3.8	0.27	1.12	0.27	35.9
5	T1	All MCs	1653	1.0	1653	1.0	*0.778	46.4	LOS D	38.0	268.4	0.89	0.80	0.89	39.7
6	R2	All MCs	105	1.0	105	1.0	0.358	80.4	LOS F	6.8	48.3	0.93	0.78	0.93	29.0
6u	U	All MCs	7	1.0	7	1.0	0.358	81.2	LOS F	6.8	48.3	0.93	0.78	0.93	30.4
Approach			1820	1.0	1820	1.0	0.778	48.0	LOS D	38.0	268.4	0.88	0.81	0.88	33.7
North: Tilley Rd_N															
7	L2	All MCs	45	1.0	45	1.0	0.059	24.3	LOS C	1.0	7.2	0.39	1.09	0.39	38.9
8	T1	All MCs	155	1.0	155	1.0	*0.762	79.0	LOS E	12.6	89.1	1.00	0.90	1.13	21.5
9	R2	All MCs	352	1.0	352	1.0	0.762	79.5	LOS E	12.6	89.1	1.00	0.89	1.10	24.1
Approach			552	1.0	552	1.0	0.762	74.8	LOS E	12.6	89.1	0.95	0.91	1.05	22.5
West: Old Cleveland Rd_W															
10	L2	All MCs	373	1.0	373	1.0	0.255	17.6	LOS B	2.0	14.3	0.15	0.83	0.15	44.6
11	T1	All MCs	1562	1.0	1562	1.0	0.774	45.4	LOS D	36.0	254.0	0.92	0.82	0.92	38.3
12	R2	All MCs	183	1.0	183	1.0	*0.778	87.3	LOS F	14.2	100.6	1.00	0.89	1.11	19.7
12u	U	All MCs	21	1.0	21	1.0	0.778	88.2	LOS F	14.2	100.6	1.00	0.89	1.11	23.0
Approach			2139	1.0	2139	1.0	0.778	44.6	LOS D	36.0	254.0	0.79	0.83	0.80	33.3
All Vehicles			4933	1.0	4933	1.0	0.778	49.9	LOS D	38.0	268.4	0.84	0.84	0.86	31.1

Site Level of Service (LOS) Method: Delay (SIDRA). Site LOS Method is specified in the Parameter Settings dialog (Options tab).

Vehicle movement LOS values are based on average delay per movement.

Intersection and Approach LOS values are based on average delay for all vehicle movements.

Delay Model: SIDRA Standard (Control Delay; Geometric Delay is included).

Queue Model: SIDRA queue estimation methods are used for Back of Queue and Queue at Start of Green.

Gap-Acceptance Capacity Formula: SIDRA Standard (Akçelik M3D).

HV (%) values are calculated for All Movement Classes of All Heavy Vehicle Model Designation.

Arrival Flows used in performance calculations are adjusted to include any Initial Queued Demand and Upstream Capacity Constraint effects.

* Critical Movement (Signal Timing)

Pedestrian Movement Performance											
Mov ID	Crossing	Input Vol.	Dem. Flow	Aver. Delay	Level of Service	AVERAGE BACK OF QUEUE	Prop. Qued	Eff. Stop	Travel Time	Travel Dist.	Aver. Speed

	ped/h	ped/h	sec		[Ped ped	Dist] m		Rate		sec	m	m/sec
West: Old Cleveland Rd_W												
P41 Stage 1	2	2	64.1	LOS F	0.0	0.0		0.96	0.96	218.0	200.0	0.92
P42 Stage 2	2	2	64.1	LOS F	0.0	0.0		0.96	0.96	218.0	200.0	0.92
All Pedestrians	4	4	64.1	LOS F	0.0	0.0		0.96	0.96	218.0	200.0	0.92

Level of Service (LOS) Method: SIDRA Pedestrian LOS Method (Based on Average Delay)

Pedestrian movement LOS values are based on average delay per pedestrian movement.

Intersection LOS value for Pedestrians is based on average delay for all pedestrian movements.

SIDRA INTERSECTION 10.0 | Copyright © 2000-2025 Akcelik and Associates Pty Ltd | sidrasolutions.com

Organisation: URBIS | Licence: NETWORK / 1PC | Processed: Tuesday, 3 February 2026 5:00:20 PM

Project: C:\Users\bchui\OneDrive - Urbis Ltd\P0046052 577 Boston Road Chandler - General\09_Transport\01_Analysis\P0046052_Boston Rd_SIDRA_260106.sipx

MOVEMENT SUMMARY

Site: [2BG37O] Archer St/ Old Cleveland Rd_2037BG_Outbound (2037 BG Outbound)

Output produced by SIDRA INTERSECTION Version: 10.0.5.217

Archer St/ Old Cleveland Rd
 Site Category: (None)
 Give-Way (Two-Way)
Site Scenario: 1 | Local Volumes

Vehicle Movement Performance															
Mov ID	Turn	Mov Class	Demand Flows	Arrival Flows	Deg. Satn	Aver. Delay	Level of Service	95% Back Of Queue	Prop. Qued	Eff. Stop Rate	Number of Cycles to Depart	Aver. Speed			
			[Total HV]	[Total HV]	v/c	sec		[Veh.]	[Dist]			km/h			
			veh/h	%	veh/h	%		veh	m						
East: Old Cleveland Rd_E															
5	T1	All MCs	1749	1.0	1749	1.0	0.451	0.1	LOSA	0.0	0.0	0.00	0.00	0.00	69.6
Approach			1749	1.0	1749	1.0	0.451	0.1	NA	0.0	0.0	0.00	0.00	0.00	69.6
North: Archer St_N															
7	L2	All MCs	84	1.0	84	1.0	0.046	5.0	LOSA	0.0	0.0	0.00	0.52	0.00	50.3
Approach			84	1.0	84	1.0	0.046	5.0	NA	0.0	0.0	0.00	0.52	0.00	50.3
West: Old Cleveland Rd_E															
10	L2	All MCs	43	1.0	43	1.0	0.023	6.7	LOSA	0.0	0.0	0.00	0.57	0.00	54.0
11	T1	All MCs	1582	1.0	1582	1.0	0.408	0.1	LOSA	0.0	0.0	0.00	0.00	0.00	69.7
Approach			1625	1.0	1625	1.0	0.408	0.3	NA	0.0	0.0	0.00	0.02	0.00	69.4
All Vehicles			3459	1.0	3459	1.0	0.451	0.3	NA	0.0	0.0	0.00	0.02	0.00	69.1

Site Level of Service (LOS) Method: Delay (SIDRA). Site LOS Method is specified in the Parameter Settings dialog (Options tab).
 Vehicle movement LOS values are based on average delay per movement.
 Minor Road Approach LOS values are based on average delay for all vehicle movements.
 NA (TWSC): Level of Service is not defined for major road approaches or the intersection as a whole for Two-Way Sign Control (HCM LOS rule).
 Two-Way Sign Control Capacity Model: SIDRA Standard.
 Delay Model: SIDRA Standard (Control Delay: Geometric Delay is included).
 Queue Model: SIDRA queue estimation methods are used for Back of Queue and Queue at Start of Gap.
 Gap-Acceptance Capacity Formula: SIDRA Standard (Akçelik M3D).
 HV (%) values are calculated for All Movement Classes of All Heavy Vehicle Model Designation.
 Arrival Flows used in performance calculations are adjusted to include any Initial Queued Demand and Upstream Capacity Constraint effects.

MOVEMENT SUMMARY

Site: [3BG370] Tilley Rd/ Boston Rd_2037BG_Outbound
(2037 BG Outbound)

Output produced by SIDRA INTERSECTION Version: 10.0.5.217

Tilley Rd/ Boston Rd
Site Category: (None)
Give-Way (Two-Way)
Site Scenario: 1 | Local Volumes

Vehicle Movement Performance															
Mov ID	Turn	Mov Class	Demand Flows		Arrival Flows		Deg. Satn	Aver. Delay	Level of Service	95% Back Of Queue		Prop. Qued	Eff. Stop Rate	Number of Cycles to Depart	Aver. Speed
			[Total HV]	[Total HV]	[Total HV]	[Total HV]	v/c	sec		[Veh.]	[Dist]				km/h
			veh/h	%	veh/h	%				veh	m				
South: Tilley Road_S															
1	L2	All MCs	15	1.0	15	1.0	0.366	8.2	LOS A	0.2	1.6	0.04	0.07	0.04	60.3
2	T1	All MCs	662	1.0	662	1.0	0.366	0.1	LOS A	0.2	1.6	0.04	0.07	0.04	69.2
3	R2	All MCs	17	1.0	17	1.0	0.366	8.9	LOS A	0.2	1.6	0.04	0.07	0.04	59.9
Approach			694	1.0	694	1.0	0.366	0.5	NA	0.2	1.6	0.04	0.07	0.04	68.7
East: Boston Road_E															
4	L2	All MCs	40	1.0	40	1.0	0.097	7.6	LOS A	0.3	2.3	0.61	0.78	0.61	50.2
5	T1	All MCs	3	1.0	3	1.0	0.097	15.6	LOS C	0.3	2.3	0.61	0.78	0.61	49.7
6	R2	All MCs	11	1.0	11	1.0	0.097	19.9	LOS C	0.3	2.3	0.61	0.78	0.61	50.2
Approach			54	1.0	54	1.0	0.097	10.5	LOS B	0.3	2.3	0.61	0.78	0.61	50.1
North: Tilley Road_N															
7	L2	All MCs	5	1.0	5	1.0	0.275	9.1	LOS A	0.1	0.8	0.03	0.04	0.03	60.7
8	T1	All MCs	513	1.0	513	1.0	0.275	0.1	LOS A	0.1	0.8	0.03	0.04	0.03	69.5
9	R2	All MCs	6	1.0	6	1.0	0.275	9.9	LOS A	0.1	0.8	0.03	0.04	0.03	60.3
Approach			524	1.0	524	1.0	0.275	0.3	NA	0.1	0.8	0.03	0.04	0.03	69.3
West: Boston Road_W															
10	L2	All MCs	1	1.0	1	1.0	0.101	8.5	LOS A	0.3	2.2	0.79	0.91	0.79	46.0
11	T1	All MCs	16	1.0	16	1.0	0.101	15.0	LOS C	0.3	2.2	0.79	0.91	0.79	45.7
12	R2	All MCs	11	1.0	11	1.0	0.101	20.1	LOS C	0.3	2.2	0.79	0.91	0.79	45.6
Approach			27	1.0	27	1.0	0.101	16.8	LOS C	0.3	2.2	0.79	0.91	0.79	45.7
All Vehicles			1299	1.0	1299	1.0	0.366	1.2	NA	0.3	2.3	0.08	0.10	0.08	66.9

Site Level of Service (LOS) Method: Delay (SIDRA). Site LOS Method is specified in the Parameter Settings dialog (Options tab).
 Vehicle movement LOS values are based on average delay per movement.
 Minor Road Approach LOS values are based on average delay for all vehicle movements.
 NA (TWSC): Level of Service is not defined for major road approaches or the intersection as a whole for Two-Way Sign Control (HCM LOS rule).
 Two-Way Sign Control Capacity Model: SIDRA Standard.
 Delay Model: SIDRA Standard (Control Delay: Geometric Delay is included).
 Queue Model: SIDRA queue estimation methods are used for Back of Queue and Queue at Start of Gap.
 Gap-Acceptance Capacity Formula: SIDRA Standard (Akçelik M3D).
 HV (%) values are calculated for All Movement Classes of All Heavy Vehicle Model Designation.
 Arrival Flows used in performance calculations are adjusted to include any Initial Queued Demand and Upstream Capacity Constraint effects.

MOVEMENT SUMMARY

Site: [4BG370] Boston Rd/ Archer St_2037BG_Outbound
(2037 BG Outbound)

Output produced by SIDRA INTERSECTION Version: 10.0.5.217

Boston Rd/ Archer St
Site Category: (None)
Give-Way (Two-Way)
Site Scenario: 1 | Local Volumes

Vehicle Movement Performance																
Mov ID	Turn	Mov Class	Demand Flows		Arrival Flows		Deg. Satn	Aver. Delay	Level of Service	95% Back Of Queue		Prop. Qued	Eff. Stop of Cycles	Number of Cycles	Aver. Speed	
			[Total HV]	[Total HV]			v/c	sec	[Veh. Dist]				Rate to Depart	km/h		
			veh/h	%	veh/h	%			veh	m						
South: Archer Street_S																
1	L2	All MCs	1	1.0	1	1.0	0.025	5.2	LOS A	0.0	0.3	0.06	0.11	0.06	54.3	
2	T1	All MCs	40	1.0	40	1.0	0.025	0.1	LOS A	0.0	0.3	0.06	0.11	0.06	58.0	
3	R2	All MCs	6	1.0	6	1.0	0.025	5.2	LOS A	0.0	0.3	0.06	0.11	0.06	53.8	
Approach			47	1.0	47	1.0	0.025	0.8	NA	0.0	0.3	0.06	0.11	0.06	57.2	
East: Boston Road_E																
4	L2	All MCs	1	1.0	1	1.0	0.025	5.8	LOS A	0.1	0.6	0.24	0.54	0.24	48.6	
5	T1	All MCs	15	1.0	15	1.0	0.025	4.7	LOS A	0.1	0.6	0.24	0.54	0.24	53.2	
6	R2	All MCs	11	1.0	11	1.0	0.025	6.2	LOS A	0.1	0.6	0.24	0.54	0.24	51.8	
Approach			26	1.0	26	1.0	0.025	5.3	LOS A	0.1	0.6	0.24	0.54	0.24	52.5	
North: Archer Street_N																
7	L2	All MCs	17	1.0	17	1.0	0.059	5.6	LOS A	0.1	0.7	0.04	0.16	0.04	55.6	
8	T1	All MCs	81	1.0	81	1.0	0.059	0.0	LOS A	0.1	0.7	0.04	0.16	0.04	56.8	
9	R2	All MCs	13	1.0	13	1.0	0.059	5.5	LOS A	0.1	0.7	0.04	0.16	0.04	55.3	
Approach			111	1.0	111	1.0	0.059	1.5	NA	0.1	0.7	0.04	0.16	0.04	56.3	
West: Boston Road_W																
10	L2	All MCs	7	1.0	7	1.0	0.033	5.7	LOS A	0.1	0.8	0.19	0.55	0.19	51.9	
11	T1	All MCs	11	1.0	11	1.0	0.033	4.7	LOS A	0.1	0.8	0.19	0.55	0.19	53.1	
12	R2	All MCs	18	1.0	18	1.0	0.033	6.2	LOS A	0.1	0.8	0.19	0.55	0.19	48.0	
Approach			36	1.0	36	1.0	0.033	5.6	LOS A	0.1	0.8	0.19	0.55	0.19	50.8	
All Vehicles			220	1.0	220	1.0	0.059	2.5	NA	0.1	0.8	0.09	0.26	0.09	54.6	

Site Level of Service (LOS) Method: Delay (SIDRA). Site LOS Method is specified in the Parameter Settings dialog (Options tab).
 Vehicle movement LOS values are based on average delay per movement.
 Minor Road Approach LOS values are based on average delay for all vehicle movements.
 NA (TWSC): Level of Service is not defined for major road approaches or the intersection as a whole for Two-Way Sign Control (HCM LOS rule).
 Two-Way Sign Control Capacity Model: SIDRA Standard.
 Delay Model: SIDRA Standard (Control Delay: Geometric Delay is included).
 Queue Model: SIDRA queue estimation methods are used for Back of Queue and Queue at Start of Gap.
 Gap-Acceptance Capacity Formula: SIDRA Standard (Akçelik M3D).
 HV (%) values are calculated for All Movement Classes of All Heavy Vehicle Model Designation.
 Arrival Flows used in performance calculations are adjusted to include any Initial Queued Demand and Upstream Capacity Constraint effects.

MOVEMENT SUMMARY

 Site: [1D37I] Tilley Rd/ Old Cleveland Rd_2037Dev_Inbound
(2037 Dev_Inbound)

Output produced by SIDRA INTERSECTION Version: 10.0.8.241

Tilley Rd/ Old Cleveland Rd

Site Category: (None)

Signals - EQUISAT (Fixed-Time/SCATS) Isolated Cycle Time = 140.0 seconds (Site User-Given Cycle Time)

Site Scenario: 1 | Local Volumes

Vehicle Movement Performance															
Mov ID	Turn	Mov Class	Demand Flows		Arrival Flows		Deg. Satn	Aver. Delay	Level of Service	95% Back Of Queue		Prop. Qued	Eff. Stop Rate	Number of Cycles to Depart	Aver. Speed
			[Total HV]	[Total HV]	[Total HV]	[Total HV]	v/c	sec		[Veh.]	[Dist]				km/h
			veh/h	%	veh/h	%				veh	m				
South: Tilley Rd_S															
1	L2	All MCs	128	1.0	128	1.0	0.077	10.1	LOS B	1.8	12.4	0.34	1.36	0.34	29.6
2	T1	All MCs	207	1.0	207	1.0	*0.764	69.6	LOS E	10.0	70.5	0.99	0.84	1.08	21.2
3	R2	All MCs	86	1.0	86	1.0	0.493	72.5	LOS E	5.8	40.9	0.99	0.78	0.99	22.9
Approach			422	1.0	422	1.0	0.764	52.1	LOS D	10.0	70.5	0.79	0.99	0.84	23.5
East: Old Cleveland Rd_E															
4	L2	All MCs	55	1.0	55	1.0	0.038	27.2	LOS C	0.4	2.6	0.21	0.99	0.21	37.8
5	T1	All MCs	1653	1.0	1653	1.0	*0.764	44.2	LOS D	37.7	266.1	0.88	0.79	0.88	40.4
6	R2	All MCs	145	1.0	145	1.0	0.468	79.5	LOS E	9.4	66.6	0.95	0.80	0.95	28.9
6u	U	All MCs	7	1.0	7	1.0	0.468	80.2	LOS F	9.4	66.6	0.95	0.80	0.95	30.3
Approach			1860	1.0	1860	1.0	0.764	46.6	LOS D	37.7	266.1	0.86	0.80	0.86	34.3
North: Tilley Rd_N															
7	L2	All MCs	45	1.0	45	1.0	0.068	26.3	LOS C	0.9	6.2	0.35	1.13	0.35	37.7
8	T1	All MCs	155	1.0	155	1.0	0.736	81.5	LOS F	10.8	75.9	1.00	0.87	1.09	21.8
9	R2	All MCs	338	1.0	338	1.0	*0.764	79.2	LOS E	11.9	83.7	1.00	0.89	1.11	23.7
Approach			538	1.0	538	1.0	0.764	75.4	LOS E	11.9	83.7	0.95	0.91	1.04	22.3
West: Old Cleveland Rd_W															
10	L2	All MCs	453	1.0	453	1.0	0.321	18.2	LOS B	2.5	17.7	0.18	1.31	0.18	43.5
11	T1	All MCs	1562	1.0	1562	1.0	0.763	44.2	LOS D	35.8	252.9	0.91	0.87	0.91	38.8
12	R2	All MCs	183	1.0	183	1.0	*0.764	85.9	LOS F	14.1	99.6	1.00	0.88	1.09	19.9
12u	U	All MCs	21	1.0	21	1.0	0.764	86.7	LOS F	14.1	99.6	1.00	0.88	1.09	23.2
Approach			2219	1.0	2219	1.0	0.764	42.7	LOS D	35.8	252.9	0.77	0.96	0.78	33.7
All Vehicles			5039	1.0	5039	1.0	0.764	48.4	LOS D	37.7	266.1	0.82	0.90	0.84	31.4

Site Level of Service (LOS) Method: Delay (SIDRA). Site LOS Method is specified in the Parameter Settings dialog (Options tab).

Vehicle movement LOS values are based on average delay per movement.

Intersection and Approach LOS values are based on average delay for all vehicle movements.

Delay Model: SIDRA Standard (Control Delay; Geometric Delay is included).

Queue Model: SIDRA queue estimation methods are used for Back of Queue and Queue at Start of Green.

Gap-Acceptance Capacity Formula: SIDRA Standard (Akçelik M3D).

HV (%) values are calculated for All Movement Classes of All Heavy Vehicle Model Designation.

Arrival Flows used in performance calculations are adjusted to include any Initial Queued Demand and Upstream Capacity Constraint effects.

* Critical Movement (Signal Timing)

Pedestrian Movement Performance											
Mov ID	Crossing	Input Vol.	Dem. Flow	Aver. Delay	Level of Service	AVERAGE BACK OF QUEUE	Prop. Qued	Eff. Stop	Travel Time	Travel Dist.	Aver. Speed

	ped/h	ped/h	sec		[Ped ped	Dist] m		Rate		sec	m	m/sec
West: Old Cleveland Rd_W												
P41 Stage 1	2	2	64.1	LOS F	0.0	0.0		0.96	0.96	218.0	200.0	0.92
P42 Stage 2	2	2	64.1	LOS F	0.0	0.0		0.96	0.96	218.0	200.0	0.92
All Pedestrians	4	4	64.1	LOS F	0.0	0.0		0.96	0.96	218.0	200.0	0.92

Level of Service (LOS) Method: SIDRA Pedestrian LOS Method (Based on Average Delay)

Pedestrian movement LOS values are based on average delay per pedestrian movement.

Intersection LOS value for Pedestrians is based on average delay for all pedestrian movements.

SIDRA INTERSECTION 10.0 | Copyright © 2000-2025 Akcelik and Associates Pty Ltd | sidrasolutions.com

Organisation: URBIS | Licence: NETWORK / 1PC | Processed: Thursday, 5 February 2026 12:32:02 PM

Project: C:\Users\bchui\OneDrive - Urbis Ltd\P0046052 577 Boston Road Chandler - General\09_Transport\01_Analysis\P0046052_Boston Rd_SIDRA_260106.sipx

MOVEMENT SUMMARY

Site: [2D37I] Archer St/ Old Cleveland Rd_2037Dev_Inbound
(2037 Dev_Inbound)

Output produced by SIDRA INTERSECTION Version: 10.0.5.217

Archer St/ Old Cleveland Rd

Site Category: (None)

Give-Way (Two-Way)

Site Scenario: 1 | Local Volumes

Vehicle Movement Performance															
Mov ID	Turn	Mov Class	Demand Flows	Arrival Flows	Deg. Satn	Aver. Delay	Level of Service	95% Back Of Queue	Prop. Qued	Eff. Stop Rate	Number of Cycles to Depart	Aver. Speed			
			[Total HV]	[Total HV]	v/c	sec		[Veh.]	[Dist]			km/h			
			veh/h	%	veh/h	%		veh	m						
East: Old Cleveland Rd_E															
5	T1	All MCs	1789	1.0	1789	1.0	0.462	0.1	LOSA	0.0	0.0	0.00	0.00	0.00	69.6
Approach			1789	1.0	1789	1.0	0.462	0.1	NA	0.0	0.0	0.00	0.00	0.00	69.6
North: Archer St_N															
7	L2	All MCs	77	1.0	77	1.0	0.042	5.0	LOSA	0.0	0.0	0.00	0.52	0.00	50.3
Approach			77	1.0	77	1.0	0.042	5.0	NA	0.0	0.0	0.00	0.52	0.00	50.3
West: Old Cleveland Rd_E															
10	L2	All MCs	43	1.0	43	1.0	0.023	6.7	LOSA	0.0	0.0	0.00	0.57	0.00	54.0
11	T1	All MCs	1582	1.0	1582	1.0	0.408	0.1	LOSA	0.0	0.0	0.00	0.00	0.00	69.7
Approach			1625	1.0	1625	1.0	0.408	0.3	NA	0.0	0.0	0.00	0.02	0.00	69.4
All Vehicles			3492	1.0	3492	1.0	0.462	0.3	NA	0.0	0.0	0.00	0.02	0.00	69.1

Site Level of Service (LOS) Method: Delay (SIDRA). Site LOS Method is specified in the Parameter Settings dialog (Options tab).

Vehicle movement LOS values are based on average delay per movement.

Minor Road Approach LOS values are based on average delay for all vehicle movements.

NA (TWSC): Level of Service is not defined for major road approaches or the intersection as a whole for Two-Way Sign Control (HCM LOS rule).

Two-Way Sign Control Capacity Model: SIDRA Standard.

Delay Model: SIDRA Standard (Control Delay: Geometric Delay is included).

Queue Model: SIDRA queue estimation methods are used for Back of Queue and Queue at Start of Gap.

Gap-Acceptance Capacity Formula: SIDRA Standard (Akçelik M3D).

HV (%) values are calculated for All Movement Classes of All Heavy Vehicle Model Designation.

Arrival Flows used in performance calculations are adjusted to include any Initial Queued Demand and Upstream Capacity Constraint effects.

SIDRA INTERSECTION 10.0 | Copyright © 2000-2025 Akcelik and Associates Pty Ltd | sidrasolutions.com

Organisation: URBIS | Licence: NETWORK / 1PC | Processed: Tuesday, 3 February 2026 5:00:22 PM

Project: C:\Users\bchui\OneDrive - Urbis Ltd\P0046052 577 Boston Road Chandler - General\09_Transport\01_Analysis\P0046052_Boston Rd_SIDRA_260106.sipx

MOVEMENT SUMMARY

Site: [3D37I] Tilley Rd/ Boston Rd_2037Dev_Inbound (2037 Dev_Inbound)

Output produced by SIDRA INTERSECTION Version: 10.0.5.217

Tilley Rd/ Boston Rd
 Site Category: (None)
 Give-Way (Two-Way)

Site Scenario: 1 | Local Volumes

Vehicle Movement Performance															
Mov ID	Turn	Mov Class	Demand Flows		Arrival Flows		Deg. Satn	Aver. Delay	Level of Service	95% Back Of Queue		Prop. Qued	Eff. Stop Rate	Number of Cycles to Depart	Aver. Speed
			[Total HV]	[Total HV]	[Total HV]	[Total HV]	v/c	sec		[Veh.]	[Dist]				km/h
			veh/h	%	veh/h	%				veh	m				
South: Tilley Road_S															
1	L2	All MCs	15	1.0	15	1.0	0.491	10.2	LOS B	2.6	18.1	0.27	0.36	0.40	57.5
2	T1	All MCs	662	1.0	662	1.0	0.491	1.6	LOS A	2.6	18.1	0.27	0.36	0.40	65.1
3	R2	All MCs	137	1.0	137	1.0	0.491	10.0	LOS B	2.6	18.1	0.27	0.36	0.40	57.2
Approach			814	1.0	814	1.0	0.491	3.2	NA	2.6	18.1	0.27	0.36	0.40	63.4
East: Boston Road_E															
4	L2	All MCs	26	1.0	26	1.0	0.059	7.6	LOS A	0.2	1.4	0.60	0.74	0.60	50.3
5	T1	All MCs	3	1.0	3	1.0	0.059	19.3	LOS C	0.2	1.4	0.60	0.74	0.60	49.8
6	R2	All MCs	3	1.0	3	1.0	0.059	24.6	LOS C	0.2	1.4	0.60	0.74	0.60	50.3
Approach			33	1.0	33	1.0	0.059	10.4	LOS B	0.2	1.4	0.60	0.74	0.60	50.2
North: Tilley Road_N															
7	L2	All MCs	45	1.0	45	1.0	0.297	7.1	LOS A	0.1	1.0	0.03	0.08	0.03	60.2
8	T1	All MCs	513	1.0	513	1.0	0.297	0.1	LOS A	0.1	1.0	0.03	0.08	0.03	68.8
9	R2	All MCs	6	1.0	6	1.0	0.297	9.9	LOS A	0.1	1.0	0.03	0.08	0.03	59.8
Approach			564	1.0	564	1.0	0.297	0.8	NA	0.1	1.0	0.03	0.08	0.03	67.8
West: Boston Road_W															
10	L2	All MCs	1	1.0	1	1.0	0.132	8.5	LOS A	0.4	2.8	0.85	0.93	0.85	43.4
11	T1	All MCs	16	1.0	16	1.0	0.132	19.6	LOS C	0.4	2.8	0.85	0.93	0.85	43.4
12	R2	All MCs	11	1.0	11	1.0	0.132	24.4	LOS C	0.4	2.8	0.85	0.93	0.85	43.0
Approach			27	1.0	27	1.0	0.132	21.0	LOS C	0.4	2.8	0.85	0.93	0.85	43.3
All Vehicles			1438	1.0	1438	1.0	0.491	2.7	NA	2.6	18.1	0.19	0.27	0.27	63.9

Site Level of Service (LOS) Method: Delay (SIDRA). Site LOS Method is specified in the Parameter Settings dialog (Options tab).

Vehicle movement LOS values are based on average delay per movement.

Minor Road Approach LOS values are based on average delay for all vehicle movements.

NA (TWSC): Level of Service is not defined for major road approaches or the intersection as a whole for Two-Way Sign Control (HCM LOS rule).

Two-Way Sign Control Capacity Model: SIDRA Standard.

Delay Model: SIDRA Standard (Control Delay: Geometric Delay is included).

Queue Model: SIDRA queue estimation methods are used for Back of Queue and Queue at Start of Gap.

Gap-Acceptance Capacity Formula: SIDRA Standard (Akçelik M3D).

HV (%) values are calculated for All Movement Classes of All Heavy Vehicle Model Designation.

Arrival Flows used in performance calculations are adjusted to include any Initial Queued Demand and Upstream Capacity Constraint effects.

MOVEMENT SUMMARY

Site: [4D37I] Boston Rd/ Archer St_2037Dev_Inbound (2037 Dev_Inbound)

Output produced by SIDRA INTERSECTION Version: 10.0.5.217

Boston Rd/ Archer St
 Site Category: (None)
 Give-Way (Two-Way)
 Site Scenario: 1 | Local Volumes

Vehicle Movement Performance															
Mov ID	Turn	Mov Class	Demand Flows		Arrival Flows		Deg. Satn	Aver. Delay	Level of Service	95% Back Of Queue		Prop. Qued	Eff. Stop of Cycles	Number of Cycles	Aver. Speed
			[Total HV]	%	[Total HV]	%	v/c	sec		[Veh.]	[Dist]		Rate to Depart		km/h
			veh/h		veh/h					veh	m				
South: Archer Street_S															
1	L2	All MCs	1	1.0	1	1.0	0.025	5.2	LOS A	0.0	0.3	0.06	0.11	0.06	54.3
2	T1	All MCs	40	1.0	40	1.0	0.025	0.1	LOS A	0.0	0.3	0.06	0.11	0.06	58.0
3	R2	All MCs	6	1.0	6	1.0	0.025	5.2	LOS A	0.0	0.3	0.06	0.11	0.06	53.8
Approach			47	1.0	47	1.0	0.025	0.8	NA	0.0	0.3	0.06	0.11	0.06	57.2
East: Boston Road_E															
4	L2	All MCs	1	1.0	1	1.0	0.025	5.8	LOS A	0.1	0.6	0.24	0.54	0.24	48.6
5	T1	All MCs	15	1.0	15	1.0	0.025	4.7	LOS A	0.1	0.6	0.24	0.54	0.24	53.2
6	R2	All MCs	11	1.0	11	1.0	0.025	6.2	LOS A	0.1	0.6	0.24	0.54	0.24	51.8
Approach			26	1.0	26	1.0	0.025	5.3	LOS A	0.1	0.6	0.24	0.54	0.24	52.5
North: Archer Street_N															
7	L2	All MCs	17	1.0	17	1.0	0.059	5.6	LOS A	0.1	0.7	0.04	0.16	0.04	55.6
8	T1	All MCs	81	1.0	81	1.0	0.059	0.0	LOS A	0.1	0.7	0.04	0.16	0.04	56.8
9	R2	All MCs	13	1.0	13	1.0	0.059	5.5	LOS A	0.1	0.7	0.04	0.16	0.04	55.3
Approach			111	1.0	111	1.0	0.059	1.5	NA	0.1	0.7	0.04	0.16	0.04	56.3
West: Boston Road_W															
10	L2	All MCs	7	1.0	7	1.0	0.026	5.7	LOS A	0.1	0.6	0.19	0.54	0.19	52.0
11	T1	All MCs	11	1.0	11	1.0	0.026	4.7	LOS A	0.1	0.6	0.19	0.54	0.19	53.1
12	R2	All MCs	12	1.0	12	1.0	0.026	6.2	LOS A	0.1	0.6	0.19	0.54	0.19	48.1
Approach			29	1.0	29	1.0	0.026	5.5	LOS A	0.1	0.6	0.19	0.54	0.19	51.3
All Vehicles			214	1.0	214	1.0	0.059	2.4	NA	0.1	0.7	0.09	0.25	0.09	54.8

Site Level of Service (LOS) Method: Delay (SIDRA). Site LOS Method is specified in the Parameter Settings dialog (Options tab).
 Vehicle movement LOS values are based on average delay per movement.
 Minor Road Approach LOS values are based on average delay for all vehicle movements.
 NA (TWSC): Level of Service is not defined for major road approaches or the intersection as a whole for Two-Way Sign Control (HCM LOS rule).
 Two-Way Sign Control Capacity Model: SIDRA Standard.
 Delay Model: SIDRA Standard (Control Delay: Geometric Delay is included).
 Queue Model: SIDRA queue estimation methods are used for Back of Queue and Queue at Start of Gap.
 Gap-Acceptance Capacity Formula: SIDRA Standard (Akçelik M3D).
 HV (%) values are calculated for All Movement Classes of All Heavy Vehicle Model Designation.
 Arrival Flows used in performance calculations are adjusted to include any Initial Queued Demand and Upstream Capacity Constraint effects.

MOVEMENT SUMMARY

Site: [5D371] Boston Rd/ Site Access_2037Dev_Inbound
(2037 Dev_Inbound)

Output produced by SIDRA INTERSECTION Version: 10.0.5.217

Boston Rd/ Site Access
Site Category: (None)
Give-Way (Two-Way)
Site Scenario: 1 | Local Volumes

Vehicle Movement Performance															
Mov ID	Turn	Mov Class	Demand Flows		Arrival Flows		Deg. Satn	Aver. Delay	Level of Service	95% Back Of Queue		Prop. Qued	Eff. Stop of Cycles	Number of Cycles to Depart	Aver. Speed
			[Total HV]	[Total HV]	[Total HV]	[Total HV]	v/c	sec		[Veh.]	[Dist]		Rate		km/h
			veh/h	%	veh/h	%				veh	m				
South: Site Access_S															
1	L2	All MCs	1	1.0	1	1.0	0.002	1.9	LOS A	0.0	0.0	0.13	0.40	0.13	50.9
3	R2	All MCs	1	1.0	1	1.0	0.002	2.5	LOS A	0.0	0.0	0.13	0.40	0.13	50.4
Approach			2	1.0	2	1.0	0.002	2.2	LOS A	0.0	0.0	0.13	0.40	0.13	50.7
East: Boston Road_E															
4	L2	All MCs	1	1.0	1	1.0	0.016	5.6	LOS A	0.0	0.0	0.00	0.02	0.00	58.0
5	T1	All MCs	29	1.0	29	1.0	0.016	0.0	LOS A	0.0	0.0	0.00	0.02	0.00	59.8
Approach			31	1.0	31	1.0	0.016	0.2	NA	0.0	0.0	0.00	0.02	0.00	59.8
West: Boston Road_W															
11	T1	All MCs	39	1.0	39	1.0	0.113	0.1	LOS A	0.6	3.9	0.11	0.46	0.11	55.6
12	R2	All MCs	160	1.0	160	1.0	0.113	5.6	LOS A	0.6	3.9	0.11	0.46	0.11	50.5
Approach			199	1.0	199	1.0	0.113	4.5	NA	0.6	3.9	0.11	0.46	0.11	52.0
All Vehicles			232	1.0	232	1.0	0.113	3.9	NA	0.6	3.9	0.09	0.40	0.09	53.4

Site Level of Service (LOS) Method: Delay (SIDRA). Site LOS Method is specified in the Parameter Settings dialog (Options tab).

Vehicle movement LOS values are based on average delay per movement.

Minor Road Approach LOS values are based on average delay for all vehicle movements.

NA (TWSC): Level of Service is not defined for major road approaches or the intersection as a whole for Two-Way Sign Control (HCM LOS rule).

Two-Way Sign Control Capacity Model: SIDRA Standard.

Delay Model: SIDRA Standard (Control Delay: Geometric Delay is included).

Queue Model: SIDRA queue estimation methods are used for Back of Queue and Queue at Start of Gap.

Gap-Acceptance Capacity Formula: SIDRA Standard (Akçelik M3D).

HV (%) values are calculated for All Movement Classes of All Heavy Vehicle Model Designation.

Arrival Flows used in performance calculations are adjusted to include any Initial Queued Demand and Upstream Capacity Constraint effects.

SIDRA INTERSECTION 10.0 | Copyright © 2000-2025 Akcelik and Associates Pty Ltd | sidrasolutions.com

Organisation: URBIS | Licence: NETWORK / 1PC | Processed: Tuesday, 3 February 2026 5:00:24 PM

Project: C:\Users\lbchui\OneDrive - Urbis Ltd\P0046052 577 Boston Road Chandler - General\09_Transport\01_Analysis\P0046052_Boston Rd_SIDRA_260106.sipx

MOVEMENT SUMMARY

 Site: [1D370] Tilley Rd/ Old Cleveland Rd_2037Dev_Outbound
(2037 Dev_Outbound)

Output produced by SIDRA INTERSECTION Version: 10.0.8.241

Tilley Rd/ Old Cleveland Rd

Site Category: (None)

Signals - EQUISAT (Fixed-Time/SCATS) Isolated Cycle Time = 140.0 seconds (Site User-Given Cycle Time)

Site Scenario: 1 | Local Volumes

Vehicle Movement Performance															
Mov ID	Turn	Mov Class	Demand Flows		Arrival Flows		Deg. Satn	Aver. Delay	Level of Service	95% Back Of Queue		Prop. Qued	Eff. Stop Rate	Number of Cycles to Depart	Aver. Speed
			[Total HV]	[Total HV]			v/c	sec							km/h
			veh/h	%	veh/h	%									
South: Tilley Rd_S															
1	L2	All MCs	128	1.0	128	1.0	0.076	11.9	LOS B	2.0	14.3	0.38	1.35	0.38	29.2
2	T1	All MCs	207	1.0	207	1.0	*0.837	73.0	LOS E	10.4	73.1	1.00	0.88	1.15	20.6
3	R2	All MCs	86	1.0	86	1.0	0.540	74.1	LOS E	5.9	41.4	1.00	0.78	1.00	22.6
Approach			422	1.0	422	1.0	0.837	54.7	LOS D	10.4	73.1	0.81	1.00	0.89	22.9
East: Old Cleveland Rd_E															
4	L2	All MCs	55	1.0	55	1.0	0.043	30.5	LOS C	0.4	3.1	0.21	1.05	0.21	36.6
5	T1	All MCs	1653	1.0	1653	1.0	*0.837	54.1	LOS D	41.9	296.1	0.94	0.87	0.97	36.9
6	R2	All MCs	105	1.0	105	1.0	0.371	84.1	LOS F	6.9	48.7	0.93	0.79	0.93	28.8
6u	U	All MCs	7	1.0	7	1.0	0.371	84.9	LOS F	6.9	48.7	0.93	0.79	0.93	30.2
Approach			1820	1.0	1820	1.0	0.837	55.3	LOS E	41.9	296.1	0.92	0.87	0.95	31.3
North: Tilley Rd_N															
7	L2	All MCs	45	1.0	45	1.0	0.064	23.3	LOS C	0.9	6.3	0.35	1.10	0.35	38.5
8	T1	All MCs	155	1.0	155	1.0	0.550	69.3	LOS E	9.8	69.4	0.96	0.79	0.96	23.8
9	R2	All MCs	418	1.0	418	1.0	*0.837	89.1	LOS F	15.3	108.1	1.00	0.95	1.19	23.4
Approach			618	1.0	618	1.0	0.837	79.3	LOS E	15.3	108.1	0.94	0.92	1.07	21.8
West: Old Cleveland Rd_W															
10	L2	All MCs	373	1.0	373	1.0	0.241	19.2	LOS B	2.0	14.3	0.15	0.81	0.15	45.2
11	T1	All MCs	1562	1.0	1562	1.0	0.821	52.3	LOS D	38.9	274.7	0.95	0.87	0.98	36.5
12	R2	All MCs	183	1.0	183	1.0	*0.836	97.6	LOS F	14.9	105.4	1.00	0.94	1.19	19.1
12u	U	All MCs	21	1.0	21	1.0	0.836	98.4	LOS F	14.9	105.4	1.00	0.94	1.19	22.3
Approach			2139	1.0	2139	1.0	0.836	50.9	LOS D	38.9	274.7	0.82	0.87	0.86	31.2
All Vehicles			4999	1.0	4999	1.0	0.837	56.3	LOS E	41.9	296.1	0.87	0.89	0.92	29.1

Site Level of Service (LOS) Method: Delay (SIDRA). Site LOS Method is specified in the Parameter Settings dialog (Options tab).

Vehicle movement LOS values are based on average delay per movement.

Intersection and Approach LOS values are based on average delay for all vehicle movements.

Delay Model: SIDRA Standard (Control Delay; Geometric Delay is included).

Queue Model: SIDRA queue estimation methods are used for Back of Queue and Queue at Start of Green.

Gap-Acceptance Capacity Formula: SIDRA Standard (Akçelik M3D).

HV (%) values are calculated for All Movement Classes of All Heavy Vehicle Model Designation.

Arrival Flows used in performance calculations are adjusted to include any Initial Queued Demand and Upstream Capacity Constraint effects.

* Critical Movement (Signal Timing)

Pedestrian Movement Performance											
Mov ID	Crossing	Input Vol.	Dem. Flow	Aver. Delay	Level of Service	AVERAGE BACK OF QUEUE	Prop. Qued	Eff. Stop	Travel Time	Travel Dist.	Aver. Speed

	ped/h	ped/h	sec		[Ped ped	Dist] m		Rate		sec	m	m/sec
West: Old Cleveland Rd_W												
P41 Stage 1	2	2	64.1	LOS F	0.0	0.0		0.96	0.96	218.0	200.0	0.92
P42 Stage 2	2	2	64.1	LOS F	0.0	0.0		0.96	0.96	218.0	200.0	0.92
All Pedestrians	4	4	64.1	LOS F	0.0	0.0		0.96	0.96	218.0	200.0	0.92

Level of Service (LOS) Method: SIDRA Pedestrian LOS Method (Based on Average Delay)

Pedestrian movement LOS values are based on average delay per pedestrian movement.

Intersection LOS value for Pedestrians is based on average delay for all pedestrian movements.

SIDRA INTERSECTION 10.0 | Copyright © 2000-2025 Akcelik and Associates Pty Ltd | sidrasolutions.com

Organisation: URBIS | Licence: NETWORK / 1PC | Processed: Thursday, 5 February 2026 12:34:02 PM

Project: C:\Users\bchui\OneDrive - Urbis Ltd\P0046052 577 Boston Road Chandler - General\09_Transport\01_Analysis\P0046052_Boston Rd_SIDRA_260106.sipx

MOVEMENT SUMMARY

Site: [2D370] Archer St/ Old Cleveland
 Rd_2037Dev_Outbound (2037 Dev_Outbound)

Output produced by SIDRA INTERSECTION Version: 10.0.5.217

Archer St/ Old Cleveland Rd
 Site Category: (None)
 Give-Way (Two-Way)
 Site Scenario: 1 | Local Volumes

Vehicle Movement Performance															
Mov ID	Turn	Mov Class	Demand Flows	Arrival Flows	Deg. Satn	Aver. Delay	Level of Service	95% Back Of Queue	Prop. Qued	Eff. Stop Rate	Number of Cycles to Depart	Aver. Speed			
			[Total HV]	[Total HV]	v/c	sec		[Veh.]	[Dist]			km/h			
			veh/h	%	veh/h	%		veh	m						
East: Old Cleveland Rd_E															
5	T1	All MCs	1749	1.0	1749	1.0	0.451	0.1	LOSA	0.0	0.0	0.00	0.00	0.00	69.6
Approach			1749	1.0	1749	1.0	0.451	0.1	NA	0.0	0.0	0.00	0.00	0.00	69.6
North: Archer St_N															
7	L2	All MCs	117	1.0	117	1.0	0.063	5.0	LOSA	0.0	0.0	0.00	0.52	0.00	50.3
Approach			117	1.0	117	1.0	0.063	5.0	NA	0.0	0.0	0.00	0.52	0.00	50.3
West: Old Cleveland Rd_E															
10	L2	All MCs	43	1.0	43	1.0	0.023	6.7	LOSA	0.0	0.0	0.00	0.57	0.00	54.0
11	T1	All MCs	1582	1.0	1582	1.0	0.408	0.1	LOSA	0.0	0.0	0.00	0.00	0.00	69.7
Approach			1625	1.0	1625	1.0	0.408	0.3	NA	0.0	0.0	0.00	0.02	0.00	69.4
All Vehicles			3492	1.0	3492	1.0	0.451	0.4	NA	0.0	0.0	0.00	0.02	0.00	69.0

Site Level of Service (LOS) Method: Delay (SIDRA). Site LOS Method is specified in the Parameter Settings dialog (Options tab).
 Vehicle movement LOS values are based on average delay per movement.
 Minor Road Approach LOS values are based on average delay for all vehicle movements.
 NA (TWSC): Level of Service is not defined for major road approaches or the intersection as a whole for Two-Way Sign Control (HCM LOS rule).
 Two-Way Sign Control Capacity Model: SIDRA Standard.
 Delay Model: SIDRA Standard (Control Delay: Geometric Delay is included).
 Queue Model: SIDRA queue estimation methods are used for Back of Queue and Queue at Start of Gap.
 Gap-Acceptance Capacity Formula: SIDRA Standard (Akçelik M3D).
 HV (%) values are calculated for All Movement Classes of All Heavy Vehicle Model Designation.
 Arrival Flows used in performance calculations are adjusted to include any Initial Queued Demand and Upstream Capacity Constraint effects.

MOVEMENT SUMMARY

Site: [3D370] Tilley Rd/ Boston Rd_2037Dev_Outbound
(2037 Dev_Outbound)

Output produced by SIDRA INTERSECTION Version: 10.0.5.217

Tilley Rd/ Boston Rd
Site Category: (None)
Give-Way (Two-Way)
Site Scenario: 1 | Local Volumes

Vehicle Movement Performance															
Mov ID	Turn	Mov Class	Demand Flows		Arrival Flows		Deg. Satn	Aver. Delay	Level of Service	95% Back Of Queue		Prop. Qued	Eff. Stop Rate	Number of Cycles to Depart	Aver. Speed
			[Total HV]	[Total HV]	[Total HV]	[Total HV]	v/c	sec		[Veh.]	[Dist]				km/h
			veh/h	%	veh/h	%				veh	m				
South: Tilley Road_S															
1	L2	All MCs	15	1.0	15	1.0	0.366	8.2	LOS A	0.2	1.6	0.04	0.07	0.04	60.3
2	T1	All MCs	662	1.0	662	1.0	0.366	0.1	LOS A	0.2	1.6	0.04	0.07	0.04	69.2
3	R2	All MCs	17	1.0	17	1.0	0.366	8.9	LOS A	0.2	1.6	0.04	0.07	0.04	59.9
Approach			694	1.0	694	1.0	0.366	0.5	NA	0.2	1.6	0.04	0.07	0.04	68.7
East: Boston Road_E															
4	L2	All MCs	107	1.0	107	1.0	0.307	8.6	LOS A	1.3	8.9	0.68	0.89	0.82	48.5
5	T1	All MCs	3	1.0	3	1.0	0.307	17.8	LOS C	1.3	8.9	0.68	0.89	0.82	48.2
6	R2	All MCs	43	1.0	43	1.0	0.307	22.6	LOS C	1.3	8.9	0.68	0.89	0.82	48.6
Approach			154	1.0	154	1.0	0.307	12.7	LOS B	1.3	8.9	0.68	0.89	0.82	48.5
North: Tilley Road_N															
7	L2	All MCs	5	1.0	5	1.0	0.275	9.1	LOS A	0.1	0.8	0.03	0.04	0.03	60.7
8	T1	All MCs	513	1.0	513	1.0	0.275	0.1	LOS A	0.1	0.8	0.03	0.04	0.03	69.5
9	R2	All MCs	6	1.0	6	1.0	0.275	9.9	LOS A	0.1	0.8	0.03	0.04	0.03	60.3
Approach			524	1.0	524	1.0	0.275	0.3	NA	0.1	0.8	0.03	0.04	0.03	69.3
West: Boston Road_W															
10	L2	All MCs	1	1.0	1	1.0	0.106	8.5	LOS A	0.3	2.3	0.80	0.91	0.80	45.6
11	T1	All MCs	16	1.0	16	1.0	0.106	15.0	LOS C	0.3	2.3	0.80	0.91	0.80	45.4
12	R2	All MCs	11	1.0	11	1.0	0.106	21.8	LOS C	0.3	2.3	0.80	0.91	0.80	45.2
Approach			27	1.0	27	1.0	0.106	17.4	LOS C	0.3	2.3	0.80	0.91	0.80	45.3
All Vehicles			1399	1.0	1399	1.0	0.366	2.1	NA	1.3	8.9	0.12	0.16	0.14	64.9

Site Level of Service (LOS) Method: Delay (SIDRA). Site LOS Method is specified in the Parameter Settings dialog (Options tab).
 Vehicle movement LOS values are based on average delay per movement.
 Minor Road Approach LOS values are based on average delay for all vehicle movements.
 NA (TWSC): Level of Service is not defined for major road approaches or the intersection as a whole for Two-Way Sign Control (HCM LOS rule).
 Two-Way Sign Control Capacity Model: SIDRA Standard.
 Delay Model: SIDRA Standard (Control Delay: Geometric Delay is included).
 Queue Model: SIDRA queue estimation methods are used for Back of Queue and Queue at Start of Gap.
 Gap-Acceptance Capacity Formula: SIDRA Standard (Akçelik M3D).
 HV (%) values are calculated for All Movement Classes of All Heavy Vehicle Model Designation.
 Arrival Flows used in performance calculations are adjusted to include any Initial Queued Demand and Upstream Capacity Constraint effects.

MOVEMENT SUMMARY

Site: [4D37O] Boston Rd/ Archer St_2037Dev_Outbound
(2037 Dev_Outbound)

Output produced by SIDRA INTERSECTION Version: 10.0.5.217

Boston Rd/ Archer St
Site Category: (None)
Give-Way (Two-Way)
Site Scenario: 1 | Local Volumes

Vehicle Movement Performance															
Mov ID	Turn	Mov Class	Demand Flows		Arrival Flows		Deg. Satn	Aver. Delay	Level of Service	95% Back Of Queue		Prop. Qued	Eff. Stop of Cycles	Number of Cycles	Aver. Speed
			[Total HV]	[Total HV]	[Total HV]	[Total HV]	v/c	sec		[Veh.]	[Dist]		Rate to Depart		km/h
			veh/h	%	veh/h	%				veh	m				
South: Archer Street_S															
1	L2	All MCs	1	1.0	1	1.0	0.025	5.2	LOS A	0.0	0.3	0.06	0.11	0.06	54.3
2	T1	All MCs	40	1.0	40	1.0	0.025	0.1	LOS A	0.0	0.3	0.06	0.11	0.06	58.0
3	R2	All MCs	6	1.0	6	1.0	0.025	5.2	LOS A	0.0	0.3	0.06	0.11	0.06	53.8
Approach			47	1.0	47	1.0	0.025	0.8	NA	0.0	0.3	0.06	0.11	0.06	57.2
East: Boston Road_E															
4	L2	All MCs	1	1.0	1	1.0	0.025	5.8	LOS A	0.1	0.6	0.24	0.54	0.24	48.6
5	T1	All MCs	15	1.0	15	1.0	0.025	4.7	LOS A	0.1	0.6	0.24	0.54	0.24	53.2
6	R2	All MCs	11	1.0	11	1.0	0.025	6.2	LOS A	0.1	0.6	0.24	0.54	0.24	51.8
Approach			26	1.0	26	1.0	0.025	5.3	LOS A	0.1	0.6	0.24	0.54	0.24	52.5
North: Archer Street_N															
7	L2	All MCs	17	1.0	17	1.0	0.059	5.6	LOS A	0.1	0.7	0.04	0.16	0.04	55.6
8	T1	All MCs	81	1.0	81	1.0	0.059	0.0	LOS A	0.1	0.7	0.04	0.16	0.04	56.8
9	R2	All MCs	13	1.0	13	1.0	0.059	5.5	LOS A	0.1	0.7	0.04	0.16	0.04	55.3
Approach			111	1.0	111	1.0	0.059	1.5	NA	0.1	0.7	0.04	0.16	0.04	56.3
West: Boston Road_W															
10	L2	All MCs	7	1.0	7	1.0	0.068	5.7	LOS A	0.2	1.7	0.22	0.57	0.22	51.7
11	T1	All MCs	11	1.0	11	1.0	0.068	4.8	LOS A	0.2	1.7	0.22	0.57	0.22	52.8
12	R2	All MCs	52	1.0	52	1.0	0.068	6.2	LOS A	0.2	1.7	0.22	0.57	0.22	47.7
Approach			69	1.0	69	1.0	0.068	5.9	LOS A	0.2	1.7	0.22	0.57	0.22	49.3
All Vehicles			254	1.0	254	1.0	0.068	3.0	NA	0.2	1.7	0.12	0.30	0.12	53.6

Site Level of Service (LOS) Method: Delay (SIDRA). Site LOS Method is specified in the Parameter Settings dialog (Options tab).
 Vehicle movement LOS values are based on average delay per movement.
 Minor Road Approach LOS values are based on average delay for all vehicle movements.
 NA (TWSC): Level of Service is not defined for major road approaches or the intersection as a whole for Two-Way Sign Control (HCM LOS rule).
 Two-Way Sign Control Capacity Model: SIDRA Standard.
 Delay Model: SIDRA Standard (Control Delay: Geometric Delay is included).
 Queue Model: SIDRA queue estimation methods are used for Back of Queue and Queue at Start of Gap.
 Gap-Acceptance Capacity Formula: SIDRA Standard (Akçelik M3D).
 HV (%) values are calculated for All Movement Classes of All Heavy Vehicle Model Designation.
 Arrival Flows used in performance calculations are adjusted to include any Initial Queued Demand and Upstream Capacity Constraint effects.

MOVEMENT SUMMARY

Site: [5D370] Boston Rd/ Site Access_2037Dev_Outbound
(2037 Dev_Outbound)

Output produced by SIDRA INTERSECTION Version: 10.0.5.217

Boston Rd/ Site Access

Site Category: (None)

Give-Way (Two-Way)

Site Scenario: 1 | Local Volumes

Vehicle Movement Performance															
Mov ID	Turn	Mov Class	Demand Flows		Arrival Flows		Deg. Satn	Aver. Delay	Level of Service	95% Back Of Queue		Prop. Qued	Eff. Stop of Cycles	Number of Cycles to Depart	Aver. Speed
			[Total HV]	[Total HV]	[Total HV]	[Total HV]	v/c	sec		[Veh.]	[Dist]		Rate	to Depart	km/h
			veh/h	%	veh/h	%				veh	m				
South: Site Access_S															
1	L2	All MCs	141	1.0	141	1.0	0.128	1.9	LOS A	0.5	3.7	0.11	0.41	0.11	51.1
3	R2	All MCs	47	1.0	47	1.0	0.128	2.0	LOS A	0.5	3.7	0.11	0.41	0.11	50.6
Approach			188	1.0	188	1.0	0.128	1.9	LOS A	0.5	3.7	0.11	0.41	0.11	50.9
East: Boston Road_E															
4	L2	All MCs	1	1.0	1	1.0	0.016	5.6	LOS A	0.0	0.0	0.00	0.02	0.00	58.0
5	T1	All MCs	29	1.0	29	1.0	0.016	0.0	LOS A	0.0	0.0	0.00	0.02	0.00	59.8
Approach			31	1.0	31	1.0	0.016	0.2	NA	0.0	0.0	0.00	0.02	0.00	59.8
West: Boston Road_W															
11	T1	All MCs	39	1.0	39	1.0	0.021	0.0	LOS A	0.0	0.0	0.01	0.02	0.01	59.8
12	R2	All MCs	1	1.0	1	1.0	0.021	5.5	LOS A	0.0	0.0	0.01	0.02	0.01	57.7
Approach			40	1.0	40	1.0	0.021	0.1	NA	0.0	0.0	0.01	0.02	0.01	59.8
All Vehicles			259	1.0	259	1.0	0.128	1.5	NA	0.5	3.7	0.08	0.30	0.08	54.3

Site Level of Service (LOS) Method: Delay (SIDRA). Site LOS Method is specified in the Parameter Settings dialog (Options tab).

Vehicle movement LOS values are based on average delay per movement.

Minor Road Approach LOS values are based on average delay for all vehicle movements.

NA (TWSC): Level of Service is not defined for major road approaches or the intersection as a whole for Two-Way Sign Control (HCM LOS rule).

Two-Way Sign Control Capacity Model: SIDRA Standard.

Delay Model: SIDRA Standard (Control Delay: Geometric Delay is included).

Queue Model: SIDRA queue estimation methods are used for Back of Queue and Queue at Start of Gap.

Gap-Acceptance Capacity Formula: SIDRA Standard (Akçelik M3D).

HV (%) values are calculated for All Movement Classes of All Heavy Vehicle Model Designation.

Arrival Flows used in performance calculations are adjusted to include any Initial Queued Demand and Upstream Capacity Constraint effects.

SIDRA INTERSECTION 10.0 | Copyright © 2000-2025 Akcelik and Associates Pty Ltd | sidrasolutions.com

Organisation: URBIS | Licence: NETWORK / 1PC | Processed: Tuesday, 3 February 2026 5:00:25 PM

Project: C:\Users\lbchui\OneDrive - Urbis Ltd\P0046052 577 Boston Road Chandler - General\09_Transport\01_Analysis\P0046052_Boston Rd_SIDRA_260106.sipx