

## STANDARD NOTES - Q

### GENERAL

- REFER SITE PLANS FOR BUILDING DESIGN WIND CLASSIFICATION.
- ALL BUILDING WORKS ARE TO COMPLY WITH THE NCC VOLUME 2 2022.
- WRITTEN DIMENSIONS SHALL TAKE PRECEDENCE OVER SCALE.
- FLOOR PLAN DIMENSIONS ARE TO FRAME.
- INTERNAL ELEVATION DIMENSIONS ARE TO PLASTERBOARD.
- THERE ARE NO ATYPICAL DESIGN FEATURES THAT PRESENT UNUSUAL WORKPLACE HEALTH & SAFETY ISSUES IN THE CONSTRUCTION, MAINTENANCE, USE, OR DEMOLITION OF THIS STRUCTURE.

### SITE & EARTHWORKS

- SITE PREPARATION & BATTERS TO COMPLY WITH ENGINEER'S SPECIFICATIONS.
- ALL LEVELS TO BE VERIFIED ON SITE BY CONTRACTOR.
- STORMWATER FROM ROOF TO BE CONNECTED TO LEGAL POINT OF DISCHARGE AS PER SITE PLAN. WHERE DISCHARGE IS TO KERB, AN APPROVED ADAPTOR MUST BE USED.

### TERMITE

- TERMITE PROTECTION INSTALLED IN ACCORDANCE WITH AS3660.1.

### SLAB & FOOTINGS

- CONCRETE SLAB, PIERS AND REINFORCING TO COMPLY WITH ENGINEERS DESIGN AND SPECIFICATIONS.
- VAPOUR BARRIER AND TO BE INSTALLED AS PER AS2870 (QLD - MEDIUM IMPACT RESISTANCE IN ACCORDANCE WITH 5.3.3.3, ITEM 'A' OF AS2870) (NSW - HIGH IMPACT RESISTANCE IN ACCORDANCE WITH 5.3.3.3 ITEM 'B' & 'C' OF AS2870).
- 50mm SAND FILL LAYER TO BE PLACED BY CONCRETER PRIOR TO SLAB PREP

### TIMBER FRAMING (WHEN APPLICABLE)

- ALL TIMBER FRAMING TO BE IN ACCORDANCE WITH NCC H1D6 & TO COMPLY WITH AS1684.2-2021 (N2/N3/N4 WIND RATING AREAS) & AS1684.3-2021 (C1/C2 WIND RATING AREAS).
- PREFAB. TIMBER ROOF TRUSSES @ 600mm MAX. CENTRES TO MANUFACTURER'S SPECIFICATIONS.
- ALL BRACING, FIXING & TIEDOWN REQUIREMENTS TO COMPLY WITH ENGINEER'S DESIGN AND SPECIFICATIONS.

### STEEL FRAMING (WHEN APPLICABLE)

- ALL STEEL FRAMING TO BE IN ACCORDANCE WITH NCC H1P1 & TO COMPLY WITH AS4100-2020, AS4055-2021, AS1170.0-2002, AS 1170.1-2002 & AS/NZS 4600-2018.
- PREFAB. STEEL ROOF TRUSSES @ 1200mm CENTRES WITH INTERMEDIATE CEILING JOISTS.
- PREFAB. STEEL ROOF TRUSSES @ 600mm CENTRES FOR TILED ROOF UP TO N4 WITH INTERMEDIATE CEILING JOISTS.
- PREFAB. STEEL ROOF TRUSSES @ 600mm CENTRES TO ALL RAKED CEILINGS WITH INTERMEDIATE CEILING JOISTS.
- PREFAB. STEEL ROOF TRUSSES @ 600mm CENTRES FOR ALL CEILINGS WITH CEILING BATTENS WITH INTERMEDIATE CEILING JOISTS.

### ROOF & WALL CLADDING

- BRICK VENEER WALLS TO COMPLY WITH NCC H1D1 & MUST COMPLY WITH AS4773.1, AS4773.2 & AS3700.
- ALL EAVE SHEETS AND FIBRE CEMENT LININGS MUST COMPLY WITH AS2908.2.
- PLASTERBOARD TO BE INSTALLED TO MANUFACTURER'S SPECIFICATIONS.
- ROOF AND WALL CLADDING TO BE IN ACCORDANCE WITH NCC H2D6 & MUST COMPLY WITH THE FOLLOWING STANDARD WHEN APPLICABLE (SHEET ROOF:AS1562.1 / ROOF TILING:AS2050 / AAC:AS5146.1 / HARDBOARD:AS1859.4).
- ALL FLASHINGS MUST COMPLY WITH AS2904.
- ALL SARKING MUST COMPLY WITH AS4200.1.

### GLAZING

- WINDOWS TO COMPLY WITH NCC H5P2 & PART 11.3.7 & 11.3.8 OF THE ABCB HOUSING PROVISIONS.
- GLAZING TO BE IN ACCORDANCE WITH NCC H1D8 & MUST COMPLY WITH AS1288 & AS2047.

### WATER PROOFING

- WATER PROOFING IS TO BE IN ACCORDANCE WITH NCC H4D1 & PART 10.2 OF THE ABCB HOUSING PROVISIONS.
- WHERE FLOOR WASTES ARE PROVIDED, OUTSIDE OF ENCLOSED SHOWERS, FLOOR GRADES ARE TO COMPLY WITH QDC 4.5 REQUIREMENTS OR RELEVANT PERFORMANCE SOLUTION.
- EXTERNAL WATERPROOFING TO BE IN ACCORDANCE WITH NCC PART H2D8 & MUST COMPLY WITH AS4654.1 & AS4654.2.
- TILED WET AREA FLOORS AND SHOWER FLOORS WHERE A 'FLOOR WASTE' IS REQUIRED, WILL GENERALLY REQUIRE TILES TO BE DIAGONALLY CUT TO ACHIEVE COMPLIANT FALLS.
- WHERE FLOOR WASTES ARE PROVIDED, OUTSIDE OF UNENCLOSED SHOWER, FLOOR GRADES MUST BE BETWEEN 1:80 MINIMUM AND 1:50 MAXIMUM IN ACCORDANCE WITH 10.2.12 OF THE ABCB HOUSING PROVISIONS OR RELEVANT PERFORMANCE SOLUTION.
- FLOOR TILES TO SHOWER AREAS MUST BE PROVIDED WITH A FLOOR GRADE BETWEEN 1:80 MINIMUM AND 1:50 MAXIMUM IN ACCORDANCE WITH 10.2.12 OF THE ABCB HOUSING PROVISIONS OR RELEVANT PERFORMANCE SOLUTION.

### CONDENSATION MANAGEMENT AND VENTILATION

- EXHAUST FAN TO WC (WHEN APPLICABLE) TO COMPLY WITH NCC H4D9 & AS1668.2.
- EXHAUST FANS, RANGEHOODS, COMBINATION EXHAUST FANS ARE DUCTED EXTERNALLY AT A MINIMUM RATE IN ACCORDANCE WITH NCC H4P7 & PART 10.8 OF THE ABCB HOUSING PROVISIONS.
- BATHROOMS OR SANITARY COMPARTMENTS WITHOUT NATURAL VENTILATION TO HAVE 10 MINUTE RUN ON TIMER LINKED TO LIGHT SWITCH.
- ANY ROOM THAT DOES NOT MEETING NATURAL VENTILATION REQUIREMENTS MUST BE PROVIDED WITH MAKE-UP AIR FROM AN ADJACENT ROOM IN ACCORDANCE WITH AS1668.2.
- WET AREAS WITHOUT SUFFICIENT NATURAL VENTILATION MUST HAVE A MINIMUM 20MM GAP TO THE UNDERSIDE OF THE DOOR TO ACHIEVE COMPLIANT VENTILATION.

### STAIRS & BALUSTRADE (WHEN APPLICABLE)

- ALL STAIRS, BARRIERS, BALUSTRADES & HANDRAILS TO BE IN ACCORDANCE WITH NCC H5 & PART 11.2 & 11.3 OF THE ABCB HOUSING PROVISIONS & MUST COMPLY WITH AS1170.1 & AS4586.

### OTHER

- PASSAGE DOORS TO SANITARY COMPARTMENTS TO BE IN ACCORDANCE WITH NCC H4F3 PART 10.4.2 OF THE ABCB HOUSING PROVISIONS.
- BUILT TO BOUNDARY WALLS TO BE BUILT IN ACCORDANCE WITH NCC H3D1 AND PARTS 9.1 TO 9.3 OF THE ABCB HOUSING PROVISIONS & AS1530. SEPARATING & EXTERNAL WALLS TO BE BUILT TO FRL 60/60/60 (WHERE APPLICABLE).
- PROVIDE MINIMUM 115mm SLOTTED GUTTER TO SUIT MAX 40m2 OF ROOF AREA PER DOWNPIPE.
- SMOKE ALARMS INSTALLED IN ACCORDANCE WITH NCC H3D6 & PART 9.5 OF THE ABCB HOUSING PROVISIONS & MUST COMPLY WITH AS3786 & AS1670.1.
- FLUES FOR ALL FIREPLACES & HEATERS (WHERE APPLICABLE) ARE TO BE INSTALLED TO MANUFACTURER'S SPECIFICATIONS AND PART 12.4 OF THE ABCB HOUSING PROVISIONS.



NOTE: SHADOWS SHOWN ON PERSPECTIVES ARE NOT SITE SPECIFIC. IT IS AN INDICATIVE REPRESENTATION OF THE BUILDING FORM.

## CONSTRUCTION DETAILS

DETAIL DESCRIPTION	REFERENCE CODE
- OUTDOOR LIVING BRICK PIER EAVE DETAILS	- CAR-EAVE-BRICK PIER-01
- OUTDOOR LIVING POST EAVE DETAILS	- CAR-EAVE-TIMBER POST-02
- GARAGE DOOR DETAILS	- CAR-GARAGE DOOR-01
- GARAGE DOOR EAVE DETAILS	- CAR-GARAGE DOOR-02
- STANDARD SOFFIT/EAVE DETAILS	- CAR-SOFFIT/EAVE-03
- BATH SPECIFICATIONS AND BATH HOB DETAILS	- CAR-BATH-01
- NOGGINGS, MANHOLE & P.C.J. DETAILS	- CAR-NOGGINGS-01
- FACE BRICK SILL DETAILS	- BRI-FACE BRICK SILL-01
- EXTERNAL OPENING HEAD DETAILS	- BRI-OPENING HEAD-01
- RENDERED BRICK SILL DETAILS	- BRI-RENDER BRICK SILL-02
- BRICK ARTICULATION DETAILS	- BRI-ARTICULATION-01
- HOUSE CONCRETE SLAB FORMWORK & CONCRETE PLUMBING RECESS DETAILS	- CON-02
- CONCRETE WET AREA WASTE DETAIL	- REFER TO DETAIL PAGE
- SURFACE WATER GRATE DETAIL	- PLM-01
- DOWNPIPE/SEWER DETAILS	- PLM-DRAINAGE-01
- WET AREA ANGLE DETAILS	- REFER TO DETAIL PAGE
- OPEN SHOWER FLOOR RECESS DETAILS	- REFER TO DETAIL PAGE
- OVERHEAD CABINET DETAILS	- REFER TO DETAIL PAGE
- VALLEY BOARD DETAILS	- REFER TO DETAIL PAGE
- TERMITE BLANKET DETAILS	- REFER TO DETAIL PAGE
- CLASSIC SHS POST DETAIL	- REFER TO DETAIL PAGE

BCC DS  
RECEIVED  
09/04/2026  
APPLICATION REF  
A007000662

CLIENT  
HN YONG FAMILY HOLDINGS PTY LTD ATF HN  
YONGFAMILY HOLDINGS TRUST & HNY  
CORPORATION UNITY PTY LTD ATF HNY  
CORPORATION UNITY TRUST

ADDRESS

LOT 4 (NO.13) CLARENCE STREET  
CALAMVALE QLD 4116

DESIGN ASHMONT 259Q

FAÇADE DESIGNER

PLAN COVER PAGE

## REVISION SCHEDULE

DATE	REV	DRW	CHK
17/03/2026	TENDER	PG1000	ANM

## BUSHFIRE ATTACK LEVEL 12.5

PLEASE REFER TO CONTRACT DOCUMENTS FOR FULL DETAILS

REFER TO PERFORMANCE SOLUTION REPORT COMPLETED BY STA CONSULTING ENGINEERS FOR THIS JOB FOR NOMINATED FALLS TO WET AREAS LOCATED IN ENSUITES AND BATHROOMS WHICH SUPERSEDE THE REQUIREMENTS AS STATED IN NCC H4D2

## BUILDING AREA

BRISBANE / NOOSA - GOLD COAST

## DESIGNER SPECIFICATION

## PRELIMINARY TENDER PLAN

THESE PLANS ARE PRELIMINARY ONLY AND DO NOT FORM PART OF THE CONTRACT

# CORAL HOMES

CORAL HOMES PTY LTD. THE COPYRIGHT IN THIS SET OF DRAWINGS IS OWNED BY OR LICENSED TO CORAL HOMES PTY LTD AND MAY NOT BE REPRODUCED, COPIED OR DEALT WITH IN ANY MANNER WHICH INFRINGES THE EXCLUSIVE RIGHTS OF CORAL HOMES PTY LTD AS PRESCRIBED BY THE COPYRIGHT ACT 1968, WITHOUT THE EXPRESS WRITTEN AUTHORISATION OF CORAL HOMES PTY LTD.

QBCC 50792/1014053 OFT 62084C  
© CORALHOMES PTY. LTD. ALL RIGHTS RESERVED.

REV: TENDER  
DATE: 17/03/2026  
REF: 45336  
SCALE: NTS  
SHEET NUMBER: 01 of 18

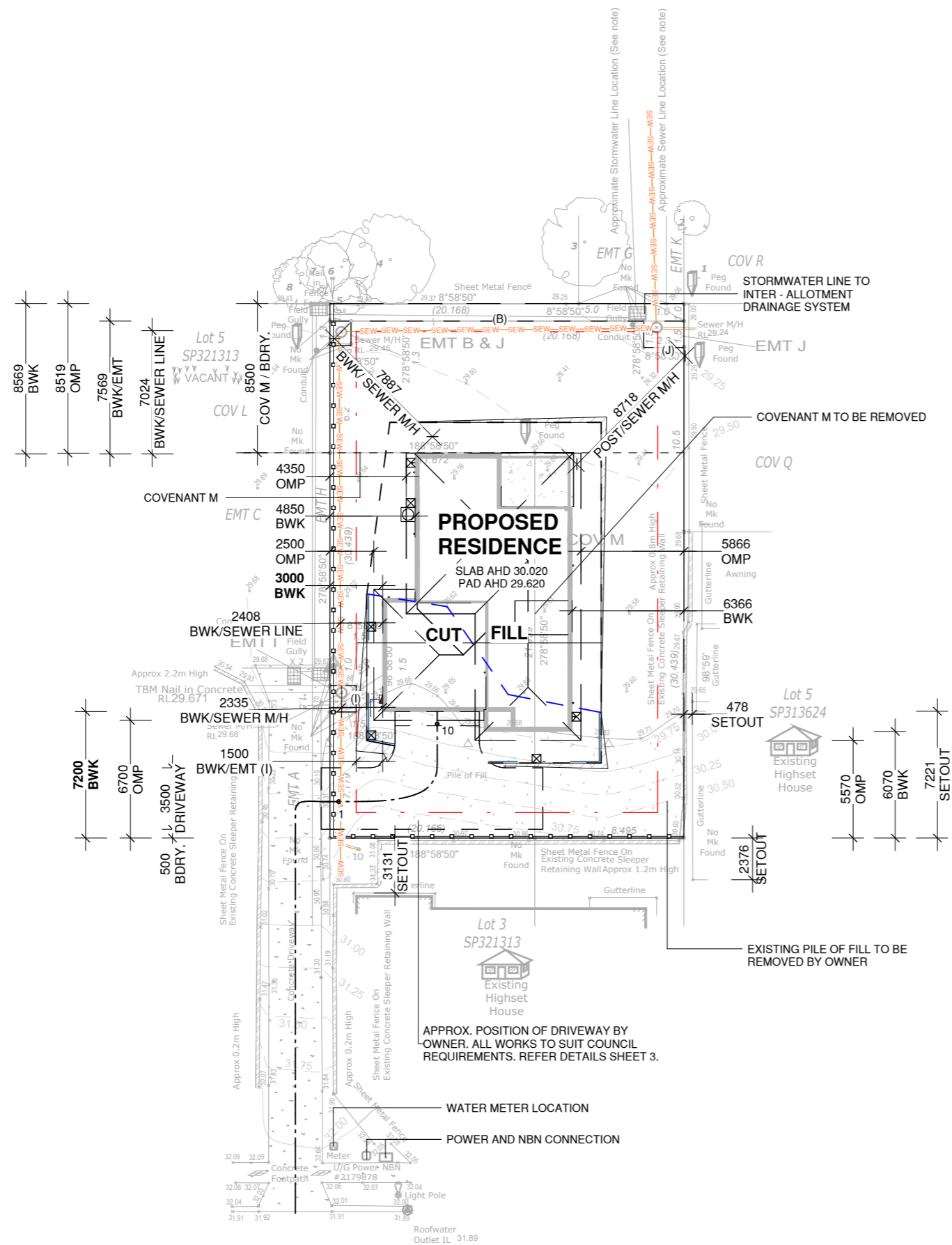
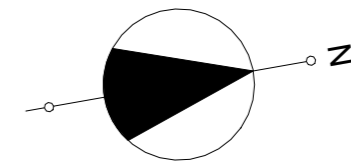

**CLARENCE STREET**

CLIENT  
 HN YONG FAMILY HOLDINGS PTY LTD ATF HN YONGFAMILY HOLDINGS TRUST & HNY COPORATION UNITY PTY LTD ATF HNY CORPORATION UNITY TRUST

ADDRESS  
 LOT 4 (NO.13) CLARENCE STREET  
 CALAMVALE QLD 4116

DESIGN ASHMONT 259Q  
 FACADE DESIGNER  
 PLAN LOCATION  
 SITE COST OPTION: 17/03/2026  
 SURVEYOR NO: X563814

**PROPERTY DESCRIPTION**

ON: SP321313  
 LOCAL AUTH: BRISBANE CITY COUNCIL

**AREAS**

LAND	SITE COVERAGE
614 m <sup>2</sup>	24.26%

**SITWORKS**  
 NOTE: PLATFORM HEIGHT & RETAINING CAN VARY DUE TO SITE CONDITIONS  
 CUT: 0.480 | PAD AHD: 29.620  
 FILL: SCRAPE | SLAB AHD: 30.020

**CRITICAL PAD LEVEL**  
 NO  YES

**PRELIMINARY TENDER PLAN**

THESE PLANS ARE PRELIMINARY ONLY AND DO NOT FORM PART OF THE CONTRACT



CORAL HOMES PTY LTD. THE COPYRIGHT IN THIS SET OF DRAWINGS IS OWNED BY OR LICENSED TO CORAL HOMES PTY LTD AND MAY NOT BE REPRODUCED, COPIED OR DEALT WITH IN ANY MANNER WHICH INFRINGES THE EXCLUSIVE RIGHTS OF CORAL HOMES PTY LTD AS PRESCRIBED BY THE COPYRIGHT ACT 1968, WITHOUT THE EXPRESS WRITTEN AUTHORISATION OF CORAL HOMES PTY LTD.

QBCC 50792/1014053 OFT 62084C  
 © CORALHOMES PTY. LTD. ALL RIGHTS RESERVED.

REV:	TENDER
DATE:	17/03/2026
REF:	45336
SCALE:	1 : 300
SHEET NUMBER:	02A of 18

BCC DS  
 RECEIVED  
 09/04/2026  
 APPLICATION REF  
 A007000662

N2

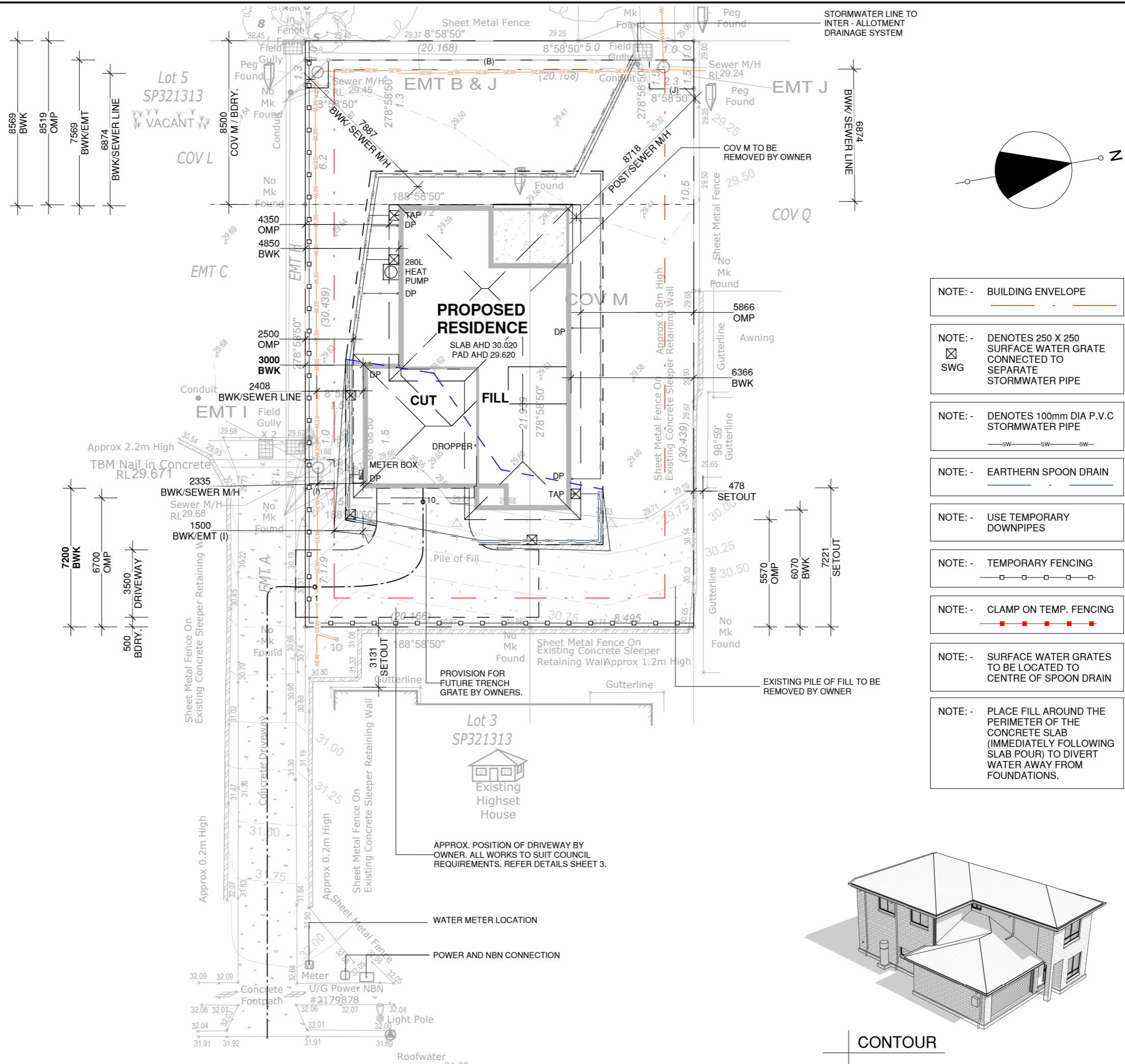

- NOTE: - BUILDING ENVELOPE
- NOTE: - DENOTES 250 X 250 SURFACE WATER GRATE CONNECTED TO SEPARATE STORMWATER PIPE
- NOTE: - DENOTES 100mm DIA P.V.C STORMWATER PIPE
- NOTE: - EARTHEN SPOON DRAIN
- NOTE: - USE TEMPORARY DOWNPIPES
- NOTE: - TEMPORARY FENCING
- NOTE: - CLAMP ON TEMP. FENCING
- NOTE: - SURFACE WATER GRATES TO BE LOCATED TO CENTRE OF SPOON DRAIN
- NOTE: - PLACE FILL AROUND THE PERIMETER OF THE CONCRETE SLAB (IMMEDIATELY FOLLOWING SLAB POUR) TO DIVERT WATER AWAY FROM FOUNDATIONS.

CLIENT  
HN YONG FAMILY HOLDINGS PTY LTD ATF HN YONG FAMILY HOLDINGS TRUST & HNY CORPORATION UNITY PTY LTD ATF HNY CORPORATION UNITY TRUST

ADDRESS  
LOT 4 (NO.13) CLARENCE STREET  
CALAMVALE QLD 4116

DESIGN ASHMONT 259Q  
FACADE DESIGNER  
PLAN SITE  
SITE COST OPTION: 17/03/2026  
SURVEYOR NO: X563814

**PROPERTY DESCRIPTION**

ON: SP321313  
LOCAL AUTH: BRISBANE CITY COUNCIL

**AREAS**

LAND	SITE COVERAGE
614 m <sup>2</sup>	24.26%

**SITWORKS**

NOTE: PLATFORM HEIGHT & RETAINING CAN VARY DUE TO SITE CONDITIONS

CUT: 0.480	PAD AHD: 29.620
FILL: SCRAPE	SLAB AHD: 30.020

**CRITICAL PAD LEVEL**

NO  YES

**PRELIMINARY TENDER PLAN**

THESE PLANS ARE PRELIMINARY ONLY AND DO NOT FORM PART OF THE CONTRACT

**CORAL HOMES**

CORAL HOMES PTY LTD. THE COPYRIGHT IN THIS SET OF DRAWINGS IS OWNED BY OR LICENSED TO CORAL HOMES PTY LTD AND MAY NOT BE REPRODUCED, COPIED OR DEALT WITH IN ANY MANNER WHICH INFRINGES THE EXCLUSIVE RIGHTS OF CORAL HOMES PTY LTD AS PRESCRIBED BY THE COPYRIGHT ACT 1968, WITHOUT THE EXPRESS WRITTEN AUTHORISATION OF CORAL HOMES PTY LTD.

QBCC 50792/1014053 OFT 62084C © CORALHOMES PTY. LTD. ALL RIGHTS RESERVED.

REV:	TENDER
DATE:	17/03/2026
REF:	45336
SCALE:	1 : 200
SHEET NUMBER:	02B of 18

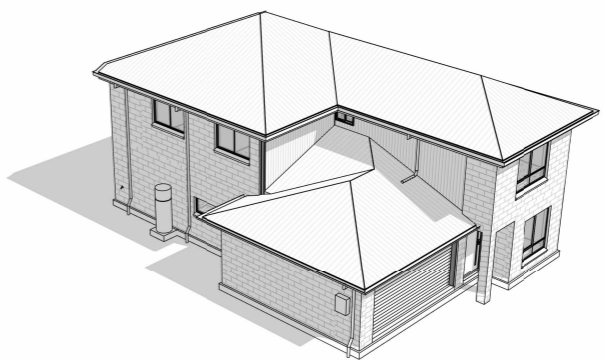

CONTOUR

BCC DS RECEIVED 09/04/2026 APPLICATION REF A007000662

**CLARENCE STREET**

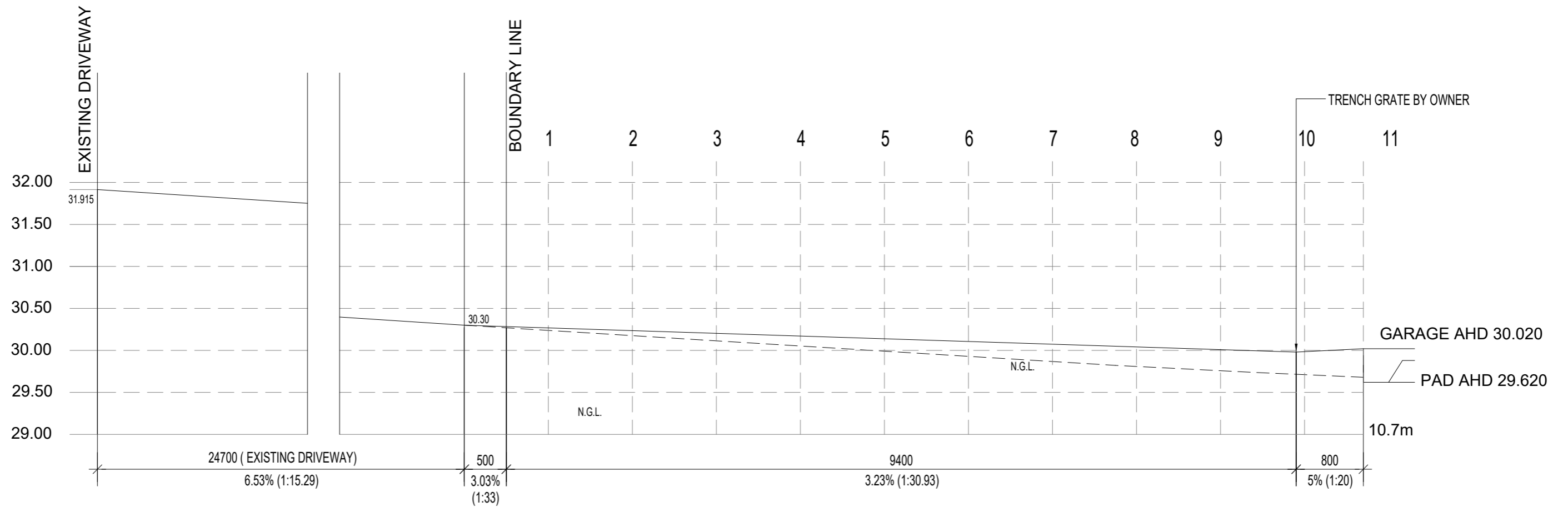

CLIENT  
 HN YONG FAMILY HOLDINGS PTY LTD  
 ATF HN YONGFAMILY HOLDINGS TRUST &  
 HNY CORPORATION UNITY PTY LTD ATF  
 HNY CORPORATION UNITY TRUST

**BCC DS**  
 RECEIVED  
 09/04/2026  
 APPLICATION REF  
 A007000662

ANCE STREET  
 6

DESIGN	ASHMONT 259Q
FACADE	DESIGNER
PLAN	DRIVEWAY LAYOUT

**PRELIMINARY  
 TENDER PLAN**

THESE PLANS ARE PRELIMINARY  
 ONLY AND DO NOT FORM  
 PART OF THE CONTRACT

**CORAL HOMES**

CORAL HOMES PTY LTD. THE COPYRIGHT IN THIS SET OF DRAWINGS IS OWNED BY OR LICENSED TO CORAL HOMES PTY LTD AND  
 MAY NOT BE REPRODUCED, COPIED OR DEALT WITH IN ANY MANNER WHICH INFRINGES THE EXCLUSIVE RIGHTS OF CORAL  
 HOMES PTY LTD AS PRESCRIBED BY THE COPYRIGHT ACT 1968, WITHOUT THE EXPRESS WRITTEN AUTHORISATION OF CORAL  
 HOMES PTY LTD.

QBCC 50792/1014053 OFT 62084C  
 © CORALHOMES PTY. LTD. ALL RIGHTS RESERVED.

REV:	TENDER
DATE:	17/03/2026
REF:	45336
SCALE:	1 : 100
SHEET NUMBER:	03 of 18

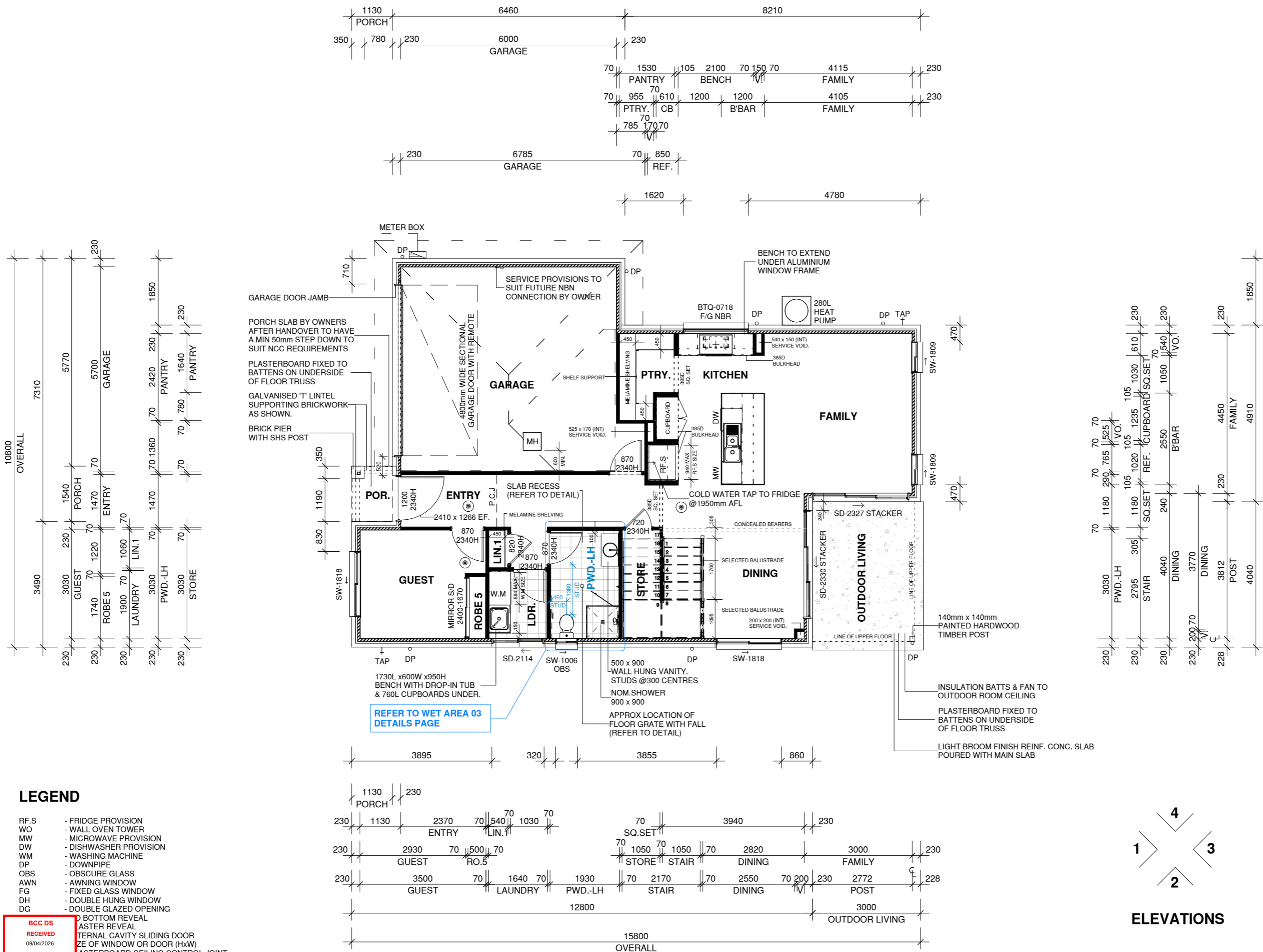

CLIENT  
 HN YONG FAMILY HOLDINGS PTY LTD ATF HN YONG FAMILY HOLDINGS TRUST & HNY CORPORATION UNITY PTY LTD ATF HNY CORPORATION UNITY TRUST

ADDRESS  
 LOT 4 (NO.13) CLARENCE STREET  
 CALAMVALE QLD 4116

DESIGN ASHMONT 259Q

FAÇADE DESIGNER

PLAN LOWER FLOOR PLAN

**AREA SCHEDULE**

	Area (m2)
LIVING (LOWER)	96.63
GARAGE	38.44
OUTDOOR LIVING	12.12
PORCH	1.74
	148.93
LIVING (UPPER)	110.46
	110.46
TOTAL	259.39

**PERIMETER SCHEDULE**

LOWER LEVEL	53.20 m
UPPER LEVEL	49.82 m

**ROOF SCHEDULE**

LOWER LEVEL	47.32 m <sup>2</sup>
UPPER LEVEL	148.36 m <sup>2</sup>

**GUTTER SCHEDULE**

	PER LENGTH
LOWER LEVEL FASCIA	16.08 m
UPPER LEVEL FASCIA	52.69 m

**PRELIMINARY TENDER PLAN**

THESE PLANS ARE PRELIMINARY ONLY AND DO NOT FORM PART OF THE CONTRACT



CORAL HOMES PTY LTD. THE COPYRIGHT IN THIS SET OF DRAWINGS IS OWNED BY OR LICENSED TO CORAL HOMES PTY LTD AND MAY NOT BE REPRODUCED, COPIED OR DEALT WITH IN ANY MANNER WHICH INFRINGES THE EXCLUSIVE RIGHTS OF CORAL HOMES PTY LTD AS PRESCRIBED BY THE COPYRIGHT ACT 1968. WITHOUT THE EXPRESS WRITTEN AUTHORISATION OF CORAL HOMES PTY LTD.

QBCC 50792/1014053 OFT 62084C  
 © CORALHOMES PTY. LTD. ALL RIGHTS RESERVED.

REV:	TENDER
DATE:	17/03/2026
REF:	45336
SCALE:	1 : 100
SHEET NUMBER:	04 of 18

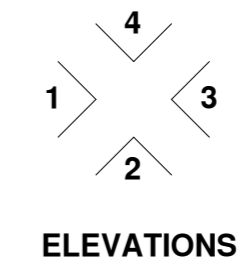



ELEVATION TOTAL AREA:	25.06 m <sup>2</sup>
LIGHTWEIGHT CLADDING:	5.15 m <sup>2</sup> (20.6%)
FACE BRICKWORK:	19.91 m <sup>2</sup> (79.4%)
FEATURE BRICKWORK:	0.00 m <sup>2</sup> (0.0%)
RENDERED BRICKWORK / AAC PANEL:	0.00 m <sup>2</sup> (0.0%)
TOTAL MATERIAL PERCENTAGE:	100%

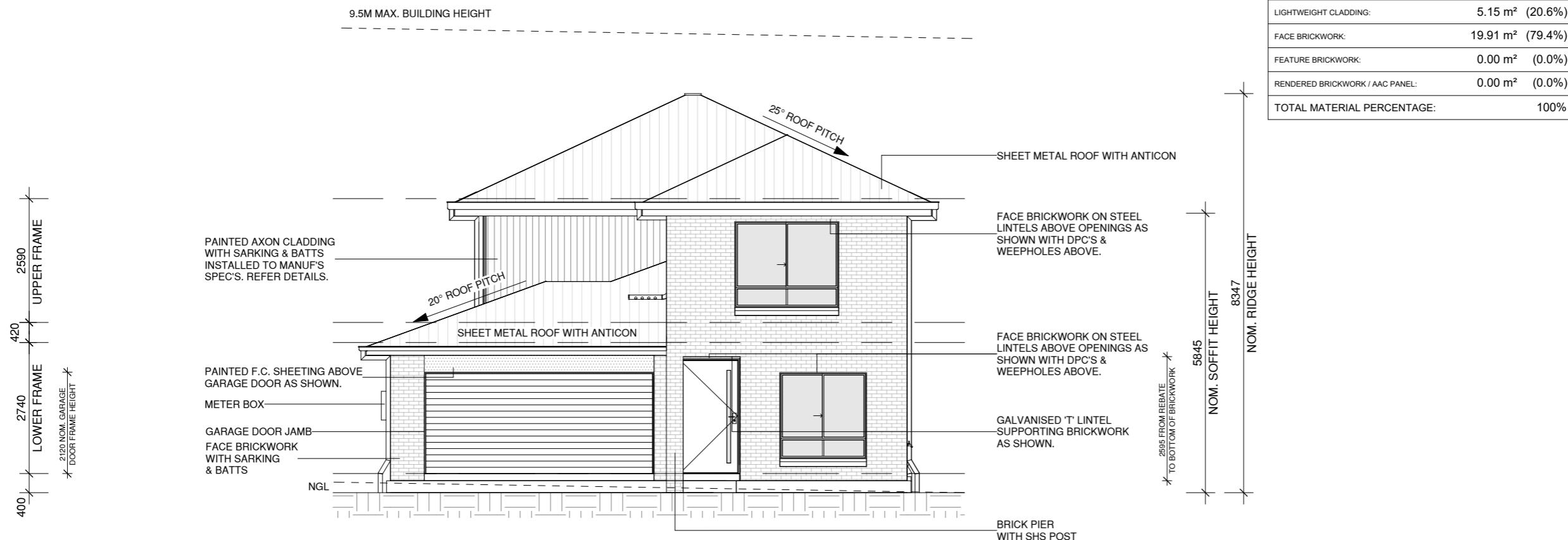

1 | ELEVATION  
SE



2 | ELEVATION  
NE

CLIENT  
HN YONG FAMILY HOLDINGS PTY LTD ATF HN YONGFAMILY HOLDINGS TRUST & HNY COPORATION UNITY PTY LTD ATF HNY CORPORATION UNITY TRUST

ADDRESS  
LOT 4 (NO.13) CLARENCE STREET  
CALAMVALE QLD 4116

DESIGN ASHMONT 259Q

FACADE DESIGNER

PLAN ELEVATION 01

**GLASS TYPE LEGEND**

	CLEAR		CLEAR TOUGHENED
	CLEAR TOUGHENED - TINT STANDARD		TINT - STANDARD
	TINT - STANDARD		TINT - DARK
	OBS - OBSCURE		OBS - OBSCURE TOUGHENED
	LOW E - STANDARD		LOW E - TINT
	LOW E - TOUGHENED		LOW E - TOUGHENED - TINT STANDARD

**MATERIAL TYPE LEGEND**

	FACE BRICKWORK		AAC PANEL
	FEATURE BRICKWORK		LINEA WEATHERBOARD
	RENDERED BRICKWORK		AXON CLADDING
	BAG N PAINT BRICKWORK		EASYLAP PANEL
	PAINTED FC SHEET		RENDERED FC SHEET
	RENDERED 9mm FC SHEET		

**NOTE:**  
PATTERNS, SIZE AND SETOUTS ARE INDICITIVE ONLY AND ARE NOT TO BE USED FOR ANY OTHER PURPOSE

**PRELIMINARY TENDER PLAN**

THESE PLANS ARE PRELIMINARY ONLY AND DO NOT FORM PART OF THE CONTRACT



CORAL HOMES PTY LTD. THE COPYRIGHT IN THIS SET OF DRAWINGS IS OWNED BY OR LICENSED TO CORAL HOMES PTY LTD AND MAY NOT BE REPRODUCED, COPIED OR DEALT WITH IN ANY MANNER WHICH INFRINGES THE EXCLUSIVE RIGHTS OF CORAL HOMES PTY LTD AS PRESCRIBED BY THE COPYRIGHT ACT 1968. WITHOUT THE EXPRESS WRITTEN AUTHORISATION OF CORAL HOMES PTY LTD.

QBCC 50792/1014053 OFT 62084C  
© CORALHOMES PTY. LTD. ALL RIGHTS RESERVED.

REV:	TENDER
DATE:	17/03/2026
REF:	45336
SCALE:	1 : 100
SHEET NUMBER:	06 of 18

BCC DS  
RECEIVED  
09/04/2026  
APPLICATION REF  
A007000662

CLIENT  
 HN YONG FAMILY HOLDINGS PTY LTD ATF HN  
 YONGFAMILY HOLDINGS TRUST & HNY  
 COPORATION UNITY PTY LTD ATF HNY  
 CORPORATION UNITY TRUST

ADDRESS  
 LOT 4 (NO.13) CLARENCE STREET  
 CALAMVALE QLD 4116

DESIGN ASHMONT 259Q

FACADE DESIGNER

PLAN ELEVATION 02

GLASS TYPE LEGEND

	CLEAR		CLEAR TOUGHENED
	CLEAR TOUGHENED - TINT STANDARD		TINT - STANDARD
	OBS - OBSCURE		TINT - DARK
	OBS - OBSCURE TOUGHENED		
	LOW E - STANDARD		
	LOW E - TINT		
	LOW E - TOUGHENED		
	LOW E - TOUGHENED - TINT STANDARD		

MATERIAL TYPE LEGEND

	FACE BRICKWORK		AAC PANEL
	FEATURE BRICKWORK		LINEA WEATHERBOARD
	RENDERED BRICKWORK		AXON CLADDING
	BAG N PAINT BRICKWORK		EASYLAP PANEL
	PAINTED FC SHEET		RENDERED FC SHEET
	RENDERED 9mm FC SHEET		

**NOTE:**  
 PATTERNS, SIZE AND SETOUTS ARE  
 INDICATIVE ONLY AND ARE NOT TO BE  
 USED FOR ANY OTHER PURPOSE

**PRELIMINARY  
 TENDER PLAN**

THESE PLANS ARE PRELIMINARY  
 ONLY AND DO NOT FORM  
 PART OF THE CONTRACT

**CORAL  
 HOMES**

CORAL HOMES PTY LTD. THE COPYRIGHT IN THIS SET OF  
 DRAWINGS IS OWNED BY OR LICENSED TO CORAL HOMES PTY  
 LTD AND MAY NOT BE REPRODUCED, COPIED OR DEALT WITH  
 IN ANY MANNER WHICH INFRINGES THE EXCLUSIVE RIGHTS  
 OF CORAL HOMES PTY LTD AS PRESCRIBED BY THE  
 COPYRIGHT ACT 1968. WITHOUT THE EXPRESS WRITTEN  
 AUTHORISATION OF CORAL HOMES PTY LTD.

QBCC 50792/1014053 OFT 62084C  
 © CORALHOMES PTY. LTD. ALL RIGHTS RESERVED.

REV:	TENDER
DATE:	17/03/2026
REF:	45336
SCALE:	1 : 100
SHEET NUMBER:	07 of 18

9.5M MAX. BUILDING HEIGHT

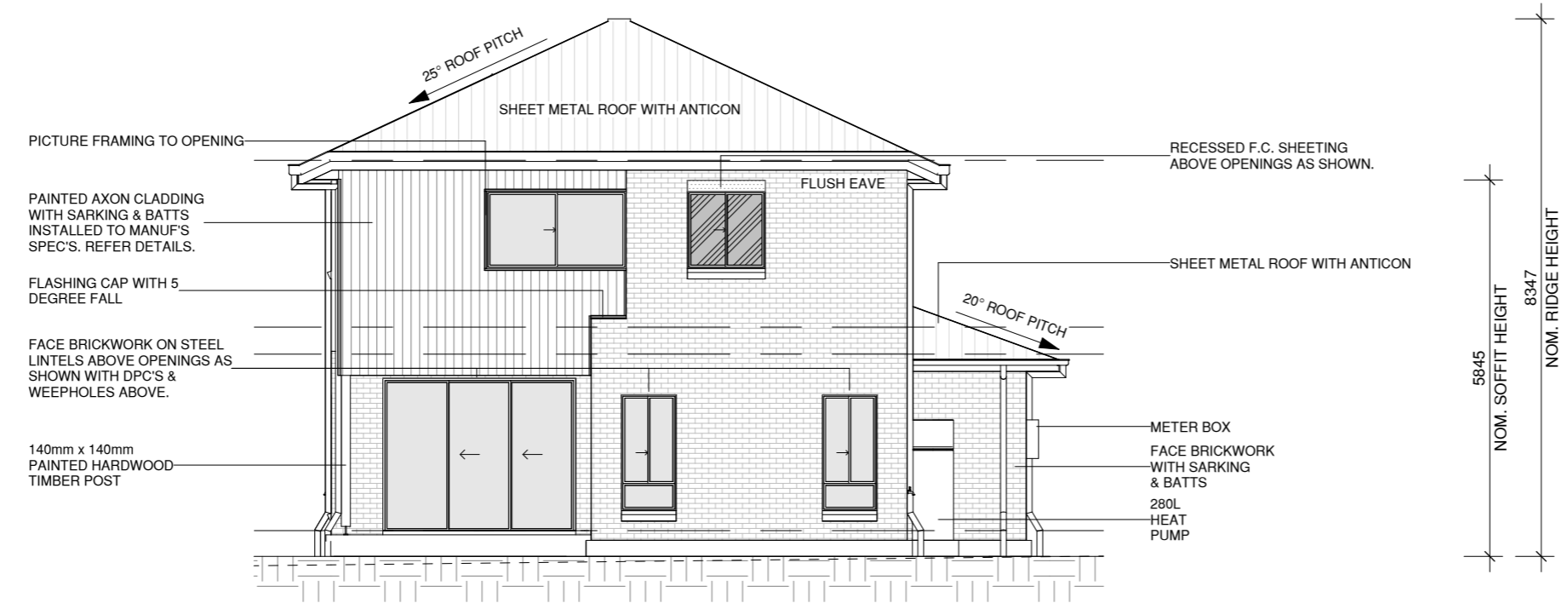

3 ELEVATION  
 NW

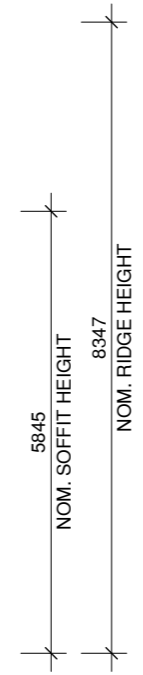
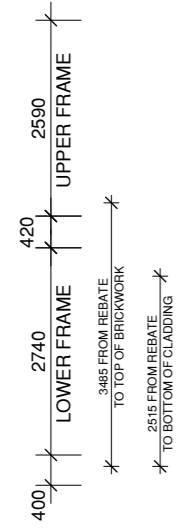

9.5M MAX. BUILDING HEIGHT

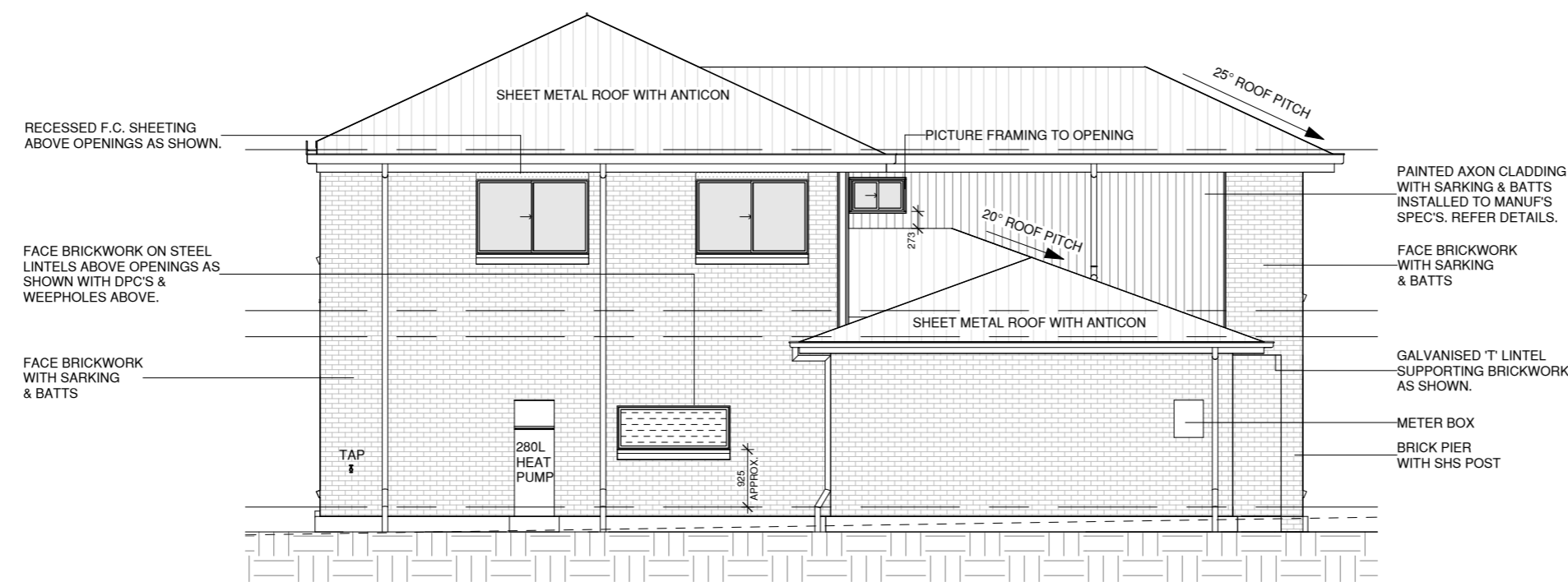

4 ELEVATION  
 SW

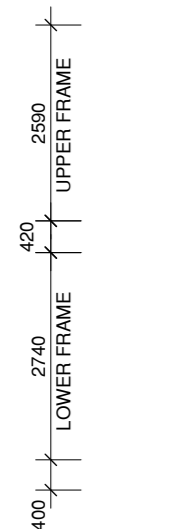

BCC DS  
 RECEIVED  
 09/04/2026  
 APPLICATION REF  
 A007000662

CLIENT  
 HN YONG FAMILY HOLDINGS PTY LTD ATF HN  
 YONGFAMILY HOLDINGS TRUST & HNY  
 COPORATION UNITY PTY LTD ATF HNY  
 CORPORATION UNITY TRUST

ADDRESS

LOT 4 (NO.13) CLARENCE STREET  
 CALAMVALE QLD 4116

DESIGN ASHMONT 259Q

FACADE DESIGNER

PLAN SLAB PLAN

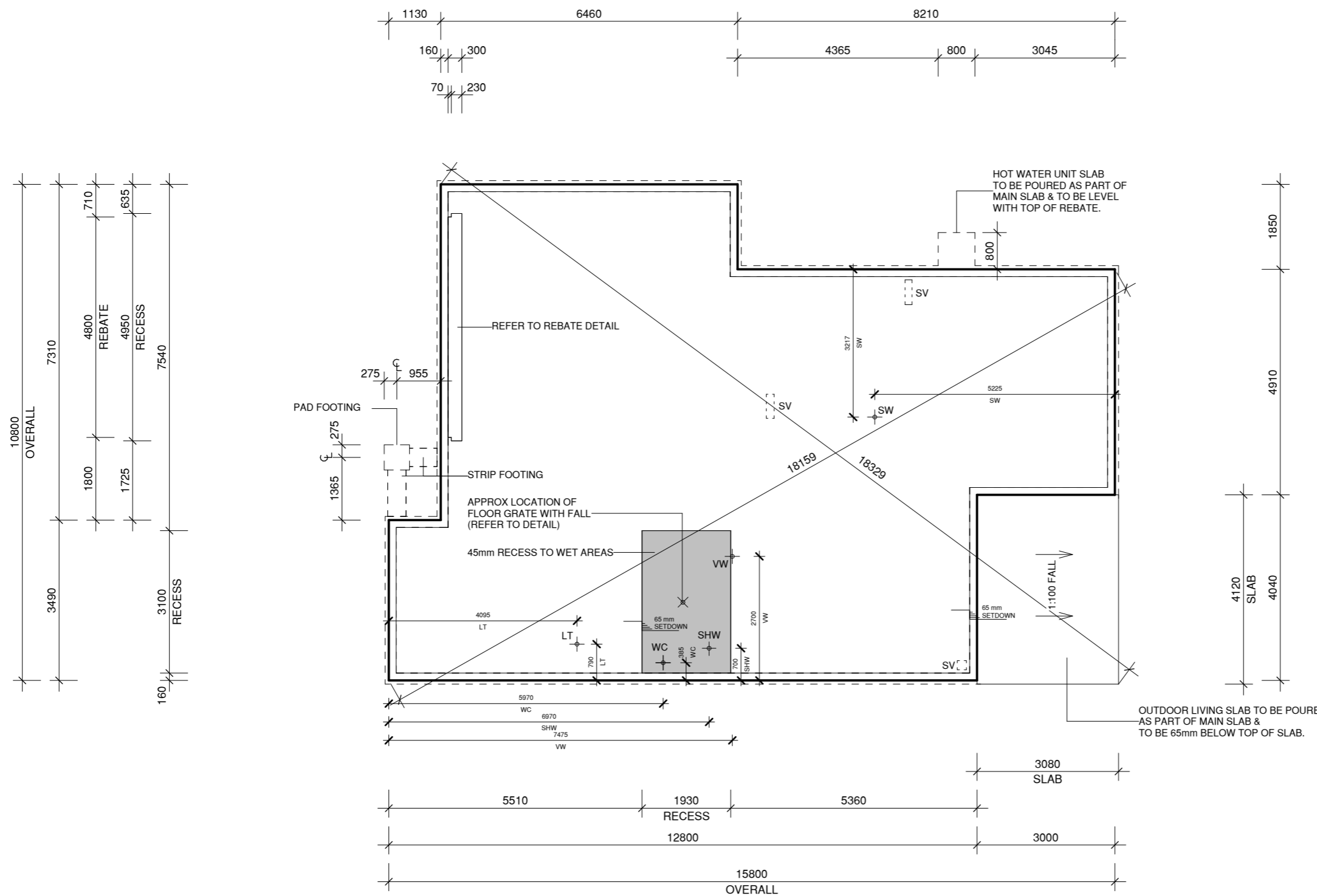

SLAB PLAN  
 1 : 100

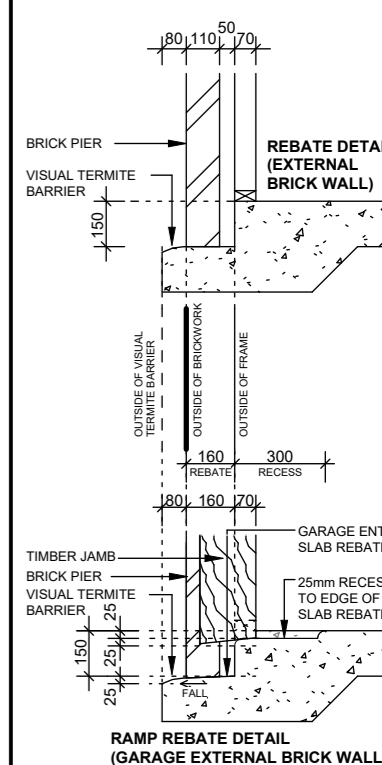

**LEGEND**

WC - WC PIPE  
 SW - SINK WASTE  
 VW - VANITY WASTE  
 LT - LDRY TUB  
 BW - BATH WASTE  
 SHW - SHOWER WASTE  
 FW - FLOOR WASTE  
 DT - DISCONNECTOR TRAP  
 VDW - VOID WASTE  
 BE - BEAM  
 RW - RISK RETAINING  
 RW - RISK WALLS

**BCC DS**  
 RECEIVED  
 09/04/2026  
 APPLICATION REF  
 A007000662

**SLAB LAYOUT**

FOOTINGS & SLAB TO BE AS PER ENGINEERS  
 DESIGN AS INDICATED WITH THE SITE INVESTIGATION

**NOTES:**

ALL DIMENSIONS ARE TO **OUTSIDE BRICKWORK**.  
 ALL DIMENSIONS WILL TAKE PRECEDENCE OVER SCALE.

**NOTES:**

PLUMBING FIXTURE & POST/PIER FOOTING DIMENSIONS ARE TO CENTRE.

DISCONNECTOR GULLIES ARE PROVIDED TO FLOORS OF ENSUITES, BATHROOMS & LAUNDRY WHEN REQUIRED TO ACT AS FIXTURE TRAP. THESE ARE TO BE POSITIONED ACCORDING TO AS3500, KEEPING CLEAR OF ALL STEPS & HOBBS.

**PRELIMINARY TENDER PLAN**

THESE PLANS ARE PRELIMINARY ONLY AND DO NOT FORM PART OF THE CONTRACT

**CORAL HOMES**

CORAL HOMES PTY LTD. THE COPYRIGHT IN THIS SET OF DRAWINGS IS OWNED BY OR LICENSED TO CORAL HOMES PTY LTD AND MAY NOT BE REPRODUCED, COPIED OR DEALT WITH IN ANY MANNER WHICH INFRINGES THE EXCLUSIVE RIGHTS OF CORAL HOMES PTY LTD AS PRESCRIBED BY THE COPYRIGHT ACT 1968, WITHOUT THE EXPRESS WRITTEN AUTHORISATION OF CORAL HOMES PTY LTD.

QBCC 50792/1014053 OFT 62084C  
 © CORALHOMES PTY. LTD. ALL RIGHTS RESERVED.

REV:	TENDER
DATE:	17/03/2026
REF:	45336
SCALE:	1 : 100
SHEET NUMBER:	08 of 18

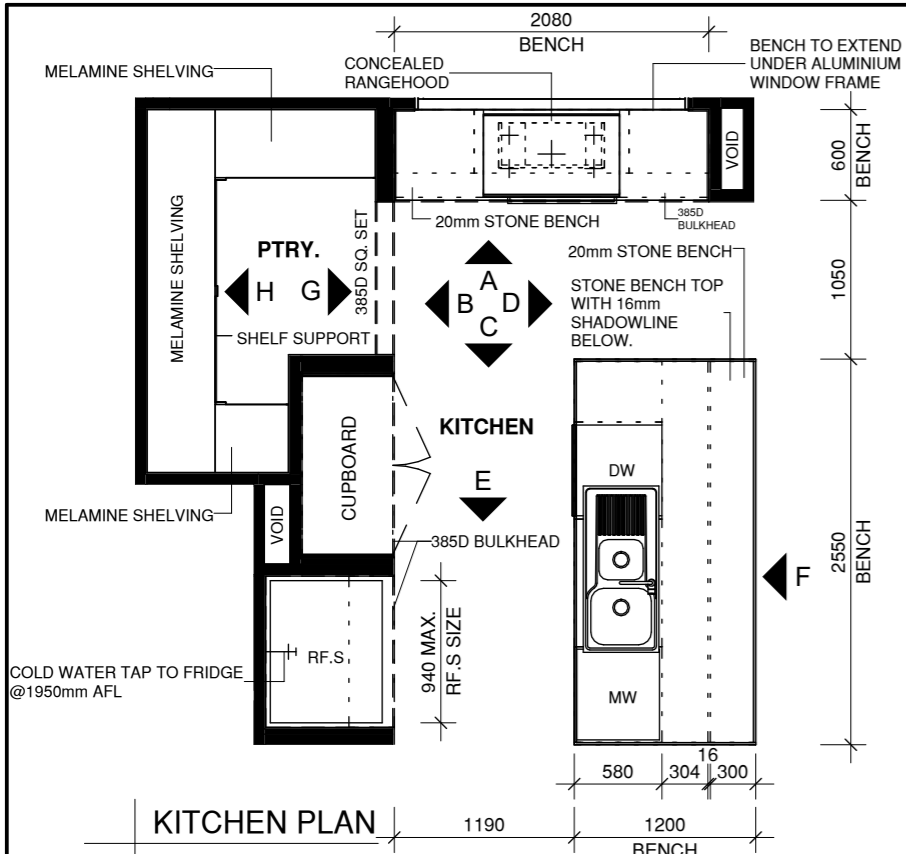

KITCHEN PLAN

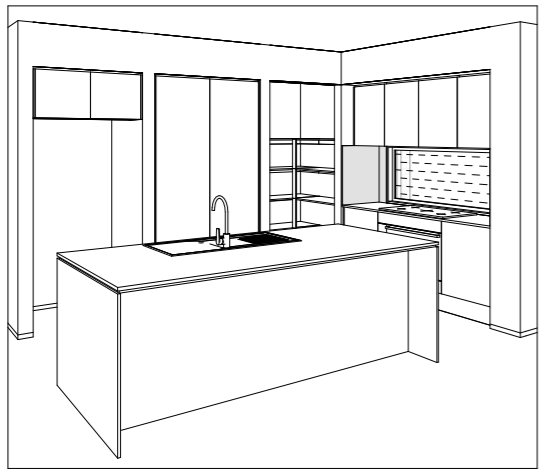

KITCHEN PERSPECTIVE

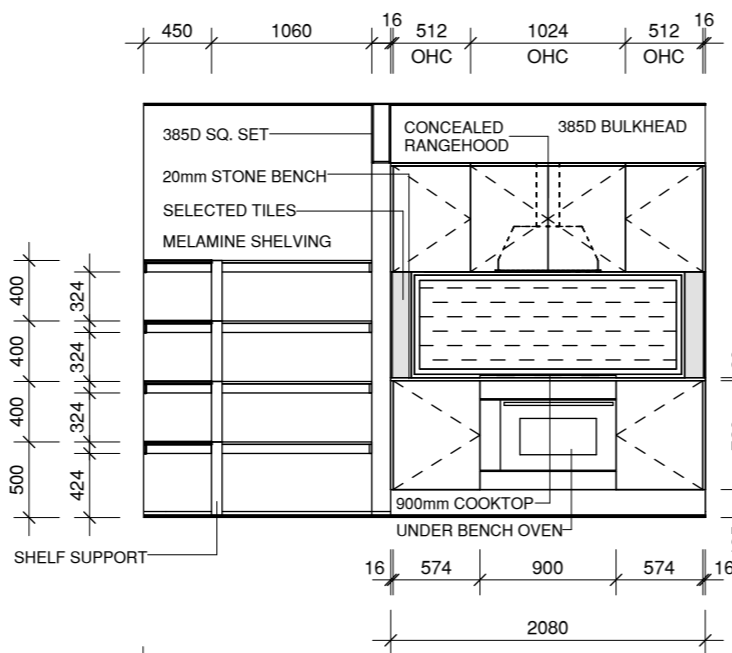

A ELEVATION

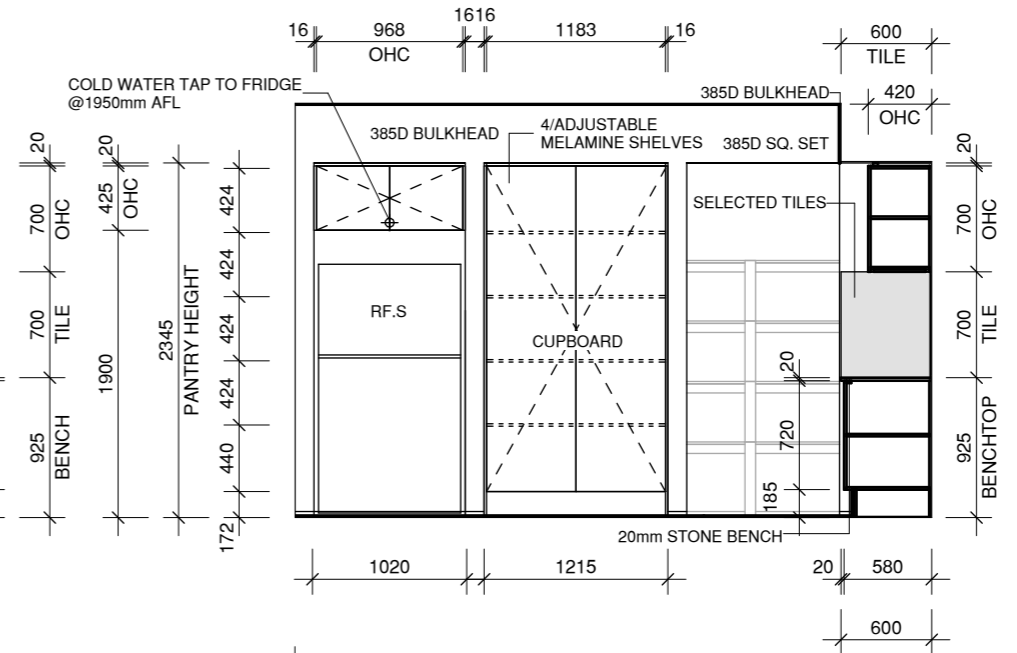

B ELEVATION

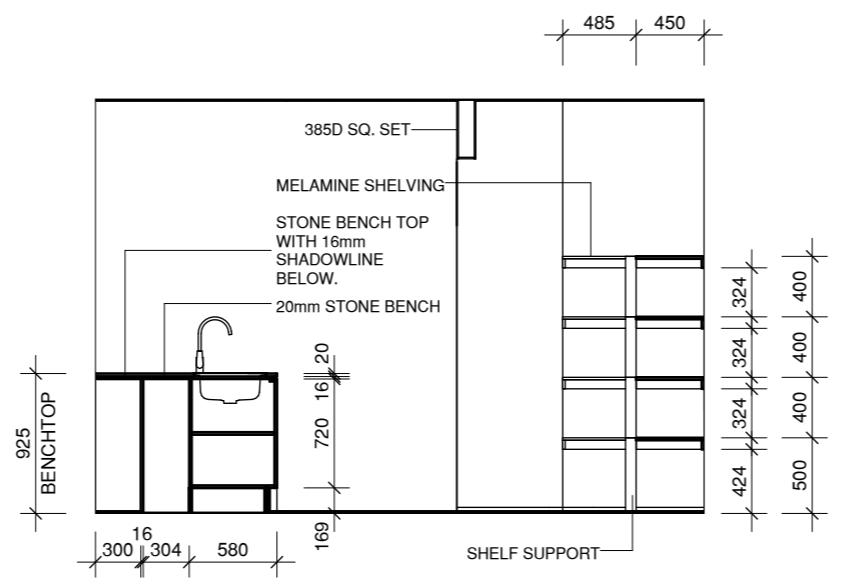

C ELEVATION

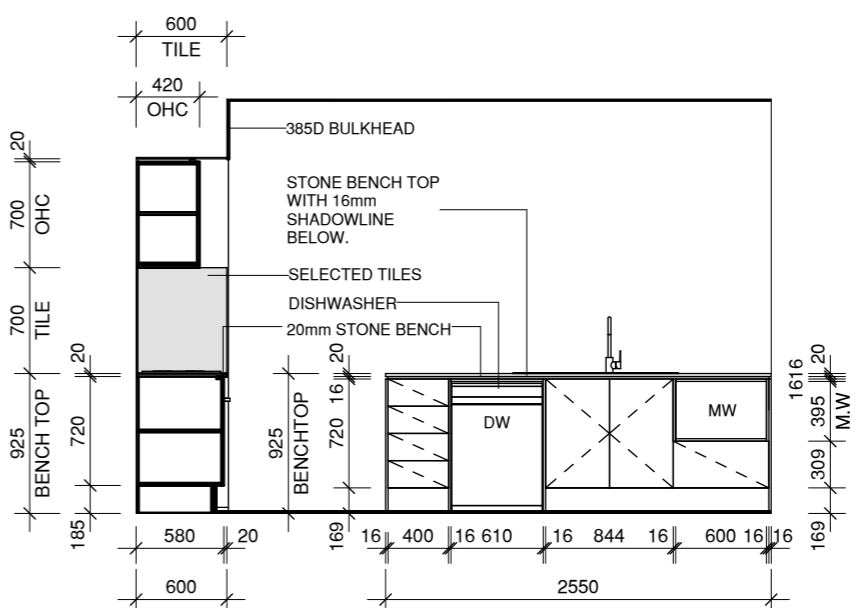

D ELEVATION

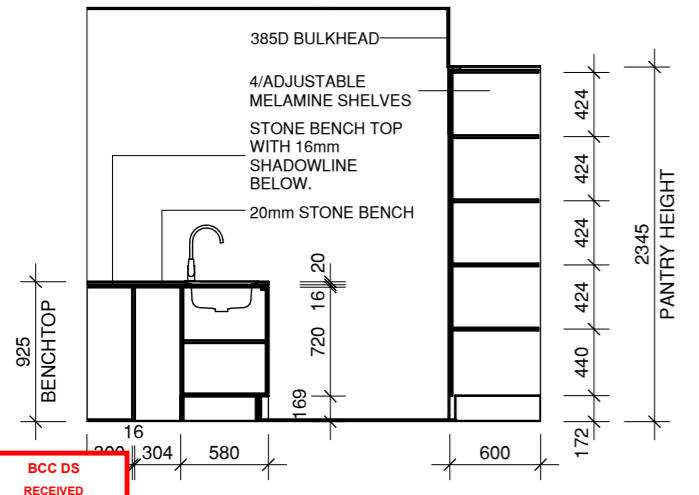

ELEVATION

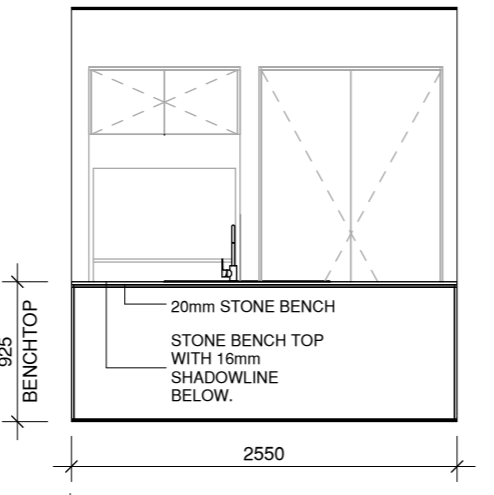

F ELEVATION

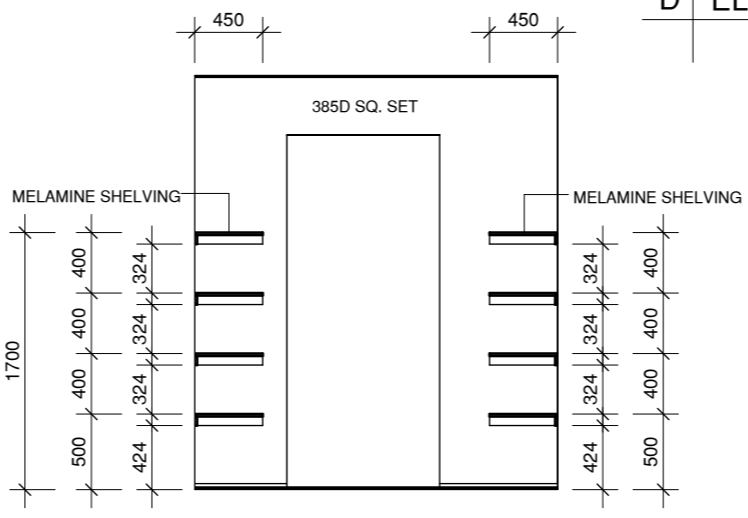

G ELEVATION

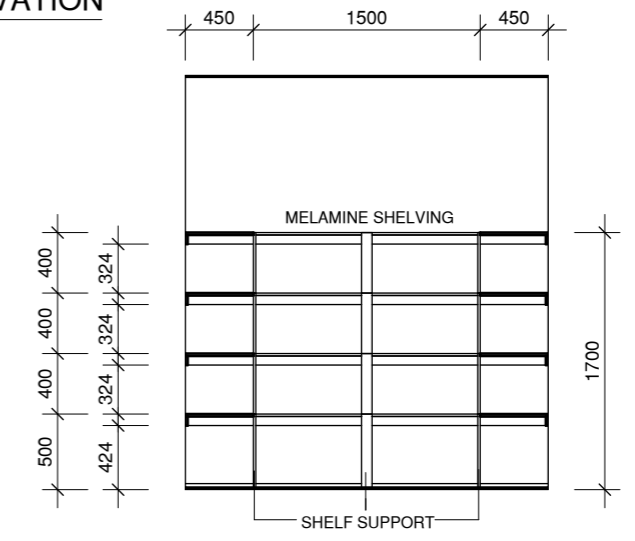

H ELEVATION

BCC DS RECEIVED 09/04/2026 APPLICATION REF A007000662

CLIENT  
HN YONG FAMILY HOLDINGS PTY LTD ATF HN YONG FAMILY HOLDINGS TRUST & HNY CORPORATION UNITY PTY LTD ATF HNY CORPORATION UNITY TRUST

ADDRESS  
LOT 4 (NO.13) CLARENCE STREET CALAMVALE QLD 4116

DESIGN ASHMONT 259Q  
FACADE DESIGNER  
PLAN RLS - KITCHEN LAYOUT

**IMPORTANT INFORMATION**  
REFER TO WORKING DRAWINGS FOR ALL ROOM DIMENSIONS, ROOM LAYOUT AND WINDOW/DOOR SIZE AND POSITION.  
ALL INTERNAL ELEVATIONS DIMENSIONS STATED ARE FROM INSIDE OF WALL LINING (BASED ON 10mm THICK WALL LININGS).  
ALL DIMENSIONS ON FLOOR PLAN ARE FROM FRAME.  
ALL DIMENSIONS ARE APPROX. ONLY AND MAY VARY DEPENDING ON PRODUCT SELECTION.

**MATERIAL LEGEND**  
SELECTED TILES

**PRELIMINARY TENDER PLAN**  
THESE PLANS ARE PRELIMINARY ONLY AND DO NOT FORM PART OF THE CONTRACT

**CORAL HOMES**

CORAL HOMES PTY LTD. THE COPYRIGHT IN THIS SET OF DRAWINGS IS OWNED BY OR LICENSED TO CORAL HOMES PTY LTD AND MAY NOT BE REPRODUCED, COPIED OR DEALT WITH IN ANY MANNER WHICH INFRINGES THE EXCLUSIVE RIGHTS OF CORAL HOMES PTY LTD AS PRESCRIBED BY THE COPYRIGHT ACT 1968. WITHOUT THE EXPRESS WRITTEN AUTHORISATION OF CORAL HOMES PTY LTD.

QBCC 50792/1014053 OFT 62084C © CORALHOMES PTY. LTD. ALL RIGHTS RESERVED.

REV: TENDER  
DATE: 17/03/2026  
REF: 45336  
SCALE: 1 : 50  
SHEET NUMBER: 09 of 18

CLIENT  
 HN YONG FAMILY HOLDINGS PTY LTD ATF HN  
 YONGFAMILY HOLDINGS TRUST & HNY  
 COPORATION UNITY PTY LTD ATF HNY  
 CORPORATION UNITY TRUST

ADDRESS

LOT 4 (NO.13) CLARENCE STREET  
 CALAMVALE QLD 4116

DESIGN ASHMONT 259Q

FACADE DESIGNER

PLAN RLS - WET AREA 01

**IMPORTANT INFORMATION**

REFER TO WORKING DRAWINGS FOR ALL ROOM DIMENSIONS, ROOM LAYOUT AND WINDOW/DOOR SIZE AND POSITION.

ALL INTERNAL ELEVATIONS DIMENSIONS STATED ARE FROM INSIDE OF WALL LINING (BASED ON 10mm THICK WALL LININGS).

ALL DIMENSIONS ON FLOOR PLAN ARE FROM FRAME.

ALL DIMENSIONS ARE APPROX. ONLY AND MAY VARY DEPENDING ON PRODUCT SELECTION, TOWEL RAILS, TOILET ROLL HOLDERS, SHOWER SCREENS, VANITIES, POWER POINTS, TILE PATTERNS, SIZE AND SETOUTS ARE INDICATIVE ONLY AND ARE NOT TO BE USED FOR ANY OTHER PURPOSE.

DISCONNECTOR GULLIES ARE PROVIDED TO FLOORS OF WET AREAS WITH BASINS AND/OR SHOWERS AND LAUNDRIES WHEN REQUIRED TO ACT AS A FIXTURE TRAP. NO DISCONNECTOR GULLIES ARE PROVIDED TO AREAS WITH KITCHEN SINKS. THESE ARE TO BE POSITIONED ACCORDING TO AS3500 AND TO BE KEPT CLEAR OF ALL STEPS & HOBS.

**MATERIAL LEGEND**

SELECTED TILES

**PRELIMINARY TENDER PLAN**

THESE PLANS ARE PRELIMINARY ONLY AND DO NOT FORM PART OF THE CONTRACT

**CORAL HOMES**

CORAL HOMES PTY LTD. THE COPYRIGHT IN THIS SET OF DRAWINGS IS OWNED BY OR LICENSED TO CORAL HOMES PTY LTD AND MAY NOT BE REPRODUCED, COPIED OR DEALT WITH IN ANY MANNER WHICH INFRINGES THE EXCLUSIVE RIGHTS OF CORAL HOMES PTY LTD AS PRESCRIBED BY THE COPYRIGHT ACT 1968, WITHOUT THE EXPRESS WRITTEN AUTHORISATION OF CORAL HOMES PTY LTD.

QBCC 50792/1014053 OFT 62084C  
 © CORALHOMES PTY. LTD. ALL RIGHTS RESERVED.

REV: TENDER  
 DATE: 17/03/2026  
 REF: 45336  
 SCALE: 1 : 50  
 SHEET NUMBER: 10 of 18

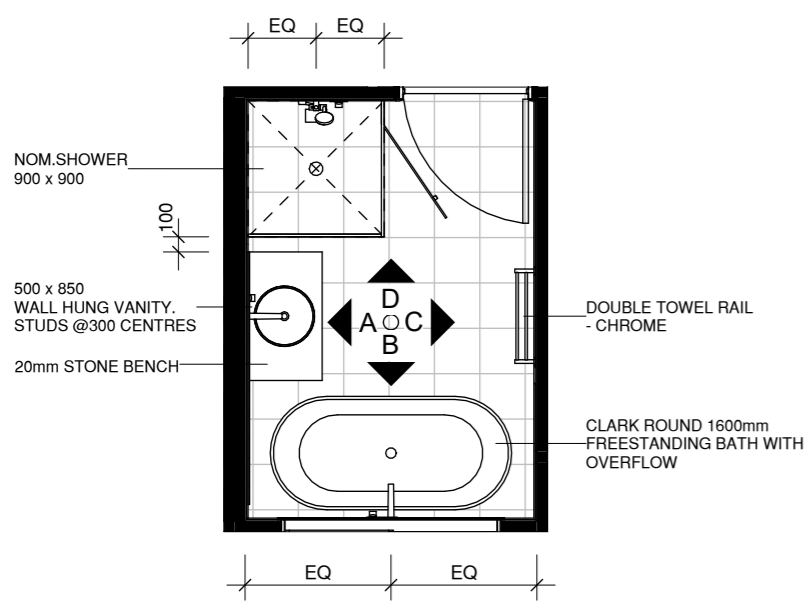

UPPER - BATH PLAN

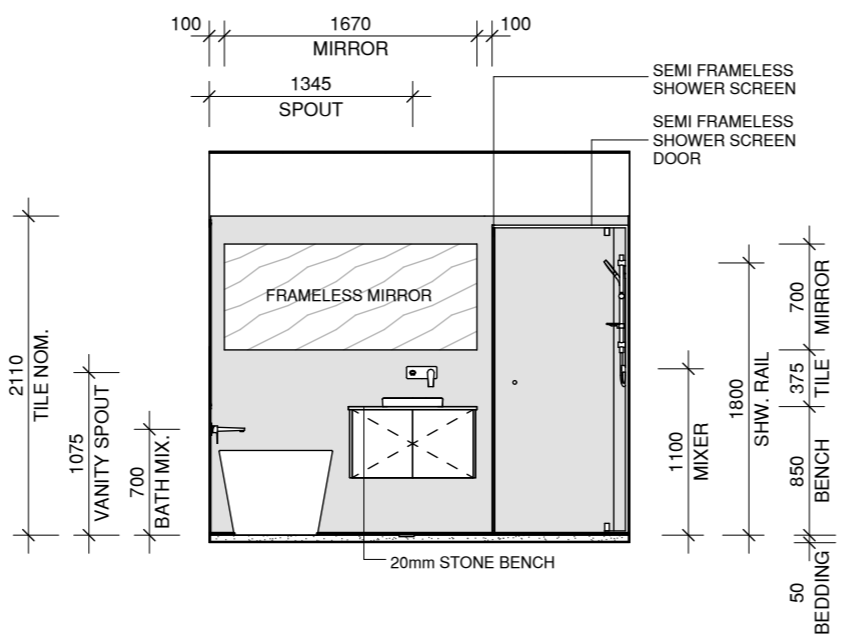

A ELEVATION

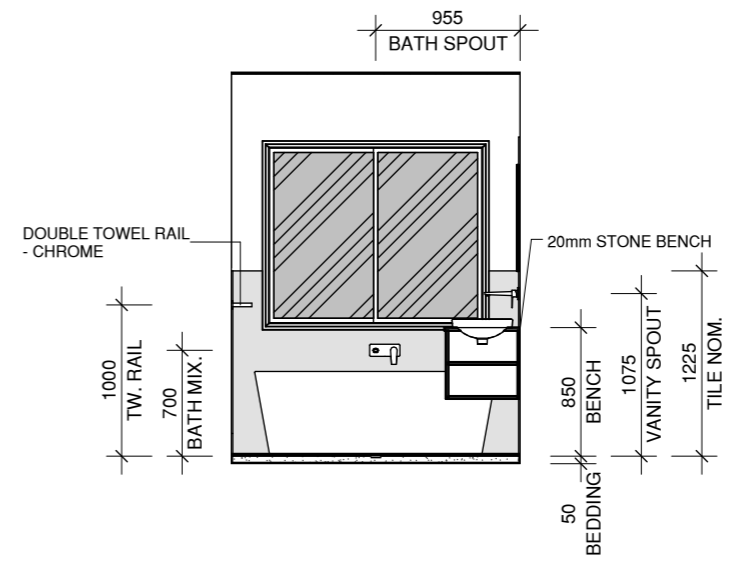

B ELEVATION

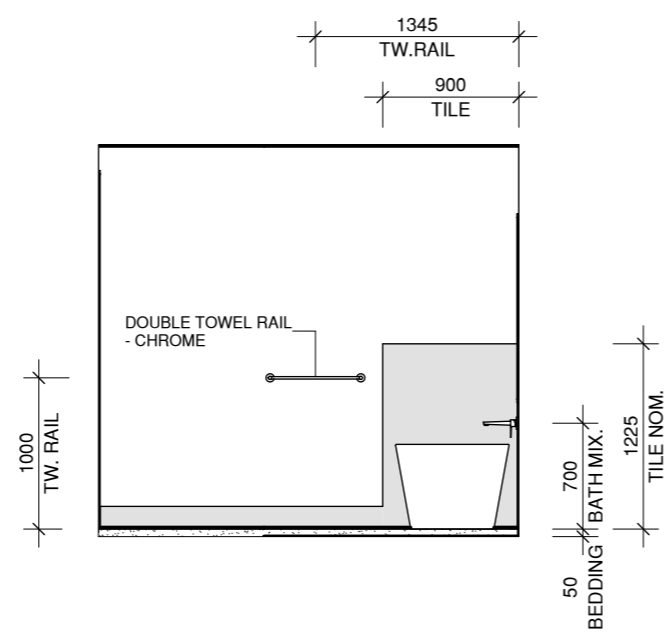

C ELEVATION

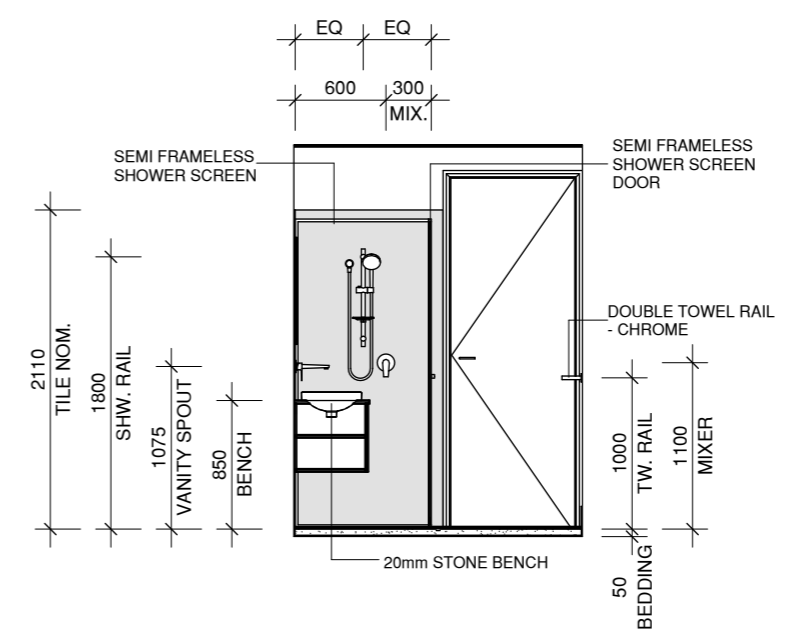

D ELEVATION

BCC DS  
 RECEIVED  
 09/04/2026  
 APPLICATION REF  
 A007000662

CLIENT  
 HN YONG FAMILY HOLDINGS PTY LTD ATF HN  
 YONGFAMILY HOLDINGS TRUST & HNY  
 CORPORATION UNITY PTY LTD ATF HNY  
 CORPORATION UNITY TRUST

ADDRESS

LOT 4 (NO.13) CLARENCE STREET  
 CALAMVALE QLD 4116

DESIGN ASHMONT 259Q

FACADE DESIGNER

PLAN RLS - WET AREA 02

**IMPORTANT INFORMATION**

REFER TO WORKING DRAWINGS FOR ALL ROOM DIMENSIONS, ROOM LAYOUT AND WINDOW/DOOR SIZE AND POSITION.

ALL INTERNAL ELEVATIONS DIMENSIONS STATED ARE FROM INSIDE OF WALL LINING (BASED ON 10mm THICK WALL LININGS).

ALL DIMENSIONS ON FLOOR PLAN ARE FROM FRAME.

ALL DIMENSIONS ARE APPROX. ONLY AND MAY VARY DEPENDING ON PRODUCT SELECTION, TOWEL RAILS, TOILET ROLL HOLDERS, SHOWER SCREENS, VANITIES, POWER POINTS, TILE PATTERNS, SIZE AND SETOUTS ARE INDICATIVE ONLY AND ARE NOT TO BE USED FOR ANY OTHER PURPOSE.

DISCONNECTOR GULLIES ARE PROVIDED TO FLOORS OF WET AREAS WITH BASINS AND/OR SHOWERS AND LAUNDRIES WHEN REQUIRED TO ACT AS A FIXTURE TRAP. NO DISCONNECTOR GULLIES ARE PROVIDED TO AREAS WITH KITCHEN SINKS. THESE ARE TO BE POSITIONED ACCORDING TO AS3500 AND TO BE KEPT CLEAR OF ALL STEPS & HOBS.

**MATERIAL LEGEND**

SELECTED TILES

**PRELIMINARY TENDER PLAN**

THESE PLANS ARE PRELIMINARY ONLY AND DO NOT FORM PART OF THE CONTRACT

**CORAL HOMES**

CORAL HOMES PTY LTD. THE COPYRIGHT IN THIS SET OF DRAWINGS IS OWNED BY OR LICENSED TO CORAL HOMES PTY LTD AND MAY NOT BE REPRODUCED, COPIED OR DEALT WITH IN ANY MANNER WHICH INFRINGES THE EXCLUSIVE RIGHTS OF CORAL HOMES PTY LTD AS PRESCRIBED BY THE COPYRIGHT ACT 1968, WITHOUT THE EXPRESS WRITTEN AUTHORISATION OF CORAL HOMES PTY LTD.

QBCC 50792/1014053 OFT 62084C  
 © CORALHOMES PTY. LTD. ALL RIGHTS RESERVED.

REV: TENDER  
 DATE: 17/03/2026  
 REF: 45336  
 SCALE: 1 : 50  
 SHEET NUMBER: 11 of 18

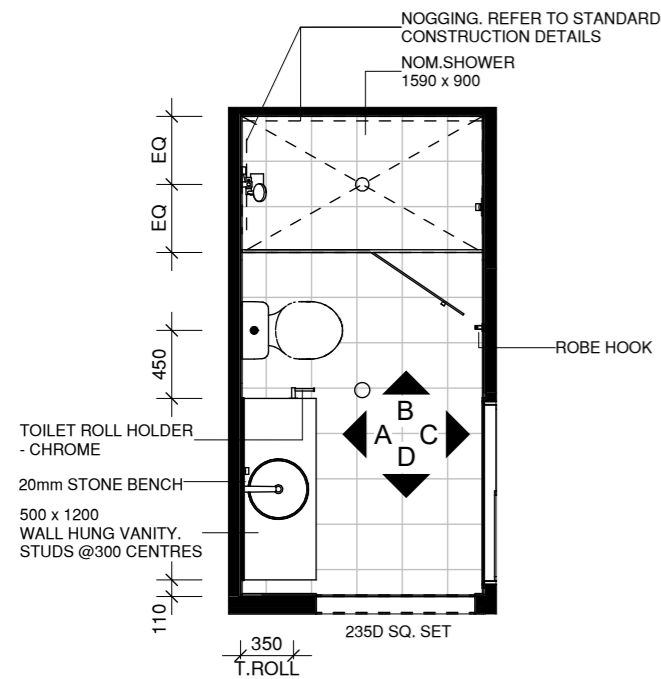

UPPER - ENSUITE-LH PLAN

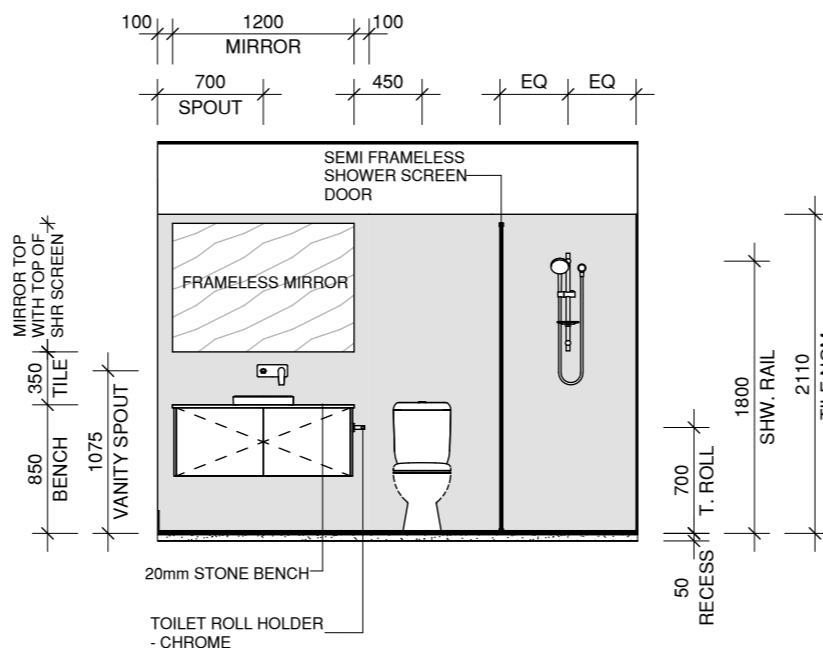

A ELEVATION

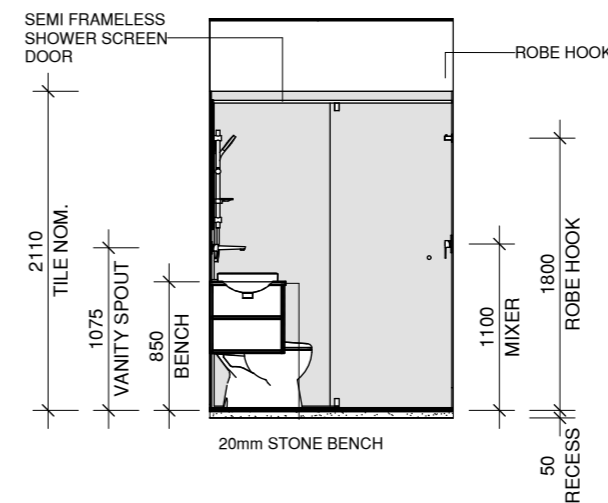

B ELEVATION

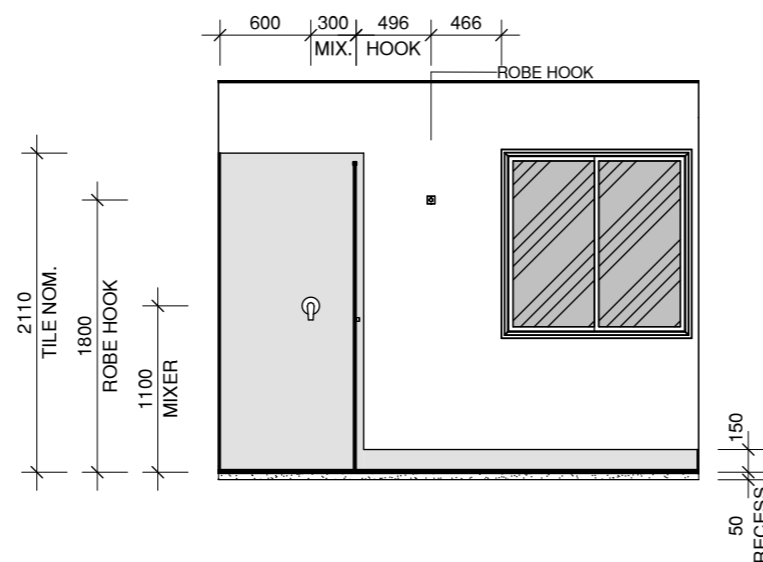

C ELEVATION

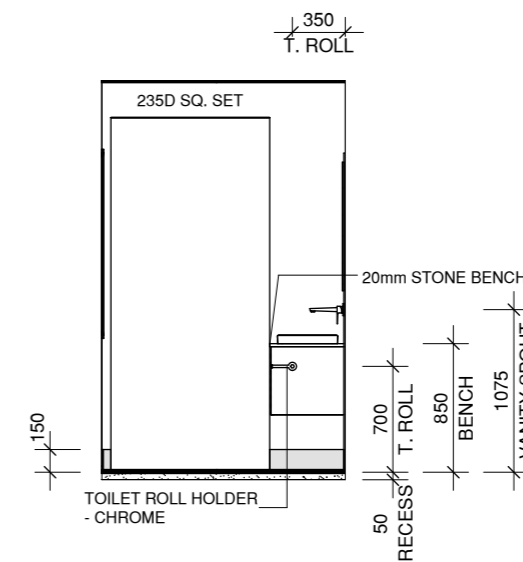

D ELEVATION

BCC DS  
 RECEIVED  
 09/04/2026  
 APPLICATION REF  
 A007000662

CLIENT  
 HN YONG FAMILY HOLDINGS PTY LTD ATF HN  
 YONGFAMILY HOLDINGS TRUST & HNY  
 COPORATION UNITY PTY LTD ATF HNY  
 CORPORATION UNITY TRUST

ADDRESS

LOT 4 (NO.13) CLARENCE STREET  
 CALAMVALE QLD 4116

DESIGN ASHMONT 259Q

FACADE DESIGNER

PLAN RLS - WET AREA 03

**IMPORTANT INFORMATION**

REFER TO WORKING DRAWINGS FOR ALL ROOM DIMENSIONS, ROOM LAYOUT AND WINDOW/DOOR SIZE AND POSITION.

ALL INTERNAL ELEVATIONS DIMENSIONS STATED ARE FROM INSIDE OF WALL LINING (BASED ON 10mm THICK WALL LININGS).

ALL DIMENSIONS ON FLOOR PLAN ARE FROM FRAME.

ALL DIMENSIONS ARE APPROX. ONLY AND MAY VARY DEPENDING ON PRODUCT SELECTION, TOWEL RAILS, TOILET ROLL HOLDERS, SHOWER SCREENS, VANITIES, POWER POINTS, TILE PATTERNS, SIZE AND SETOUTS ARE INDICATIVE ONLY AND ARE NOT TO BE USED FOR ANY OTHER PURPOSE.

DISCONNECTOR GULLIES ARE PROVIDED TO FLOORS OF WET AREAS WITH BASINS AND/OR SHOWERS AND LAUNDRIES WHEN REQUIRED TO ACT AS A FIXTURE TRAP. NO DISCONNECTOR GULLIES ARE PROVIDED TO AREAS WITH KITCHEN SINKS. THESE ARE TO BE POSITIONED ACCORDING TO AS3500 AND TO BE KEPT CLEAR OF ALL STEPS & HOBS.

**MATERIAL LEGEND**

 SELECTED TILES

**PRELIMINARY TENDER PLAN**

THESE PLANS ARE PRELIMINARY ONLY AND DO NOT FORM PART OF THE CONTRACT

**CORAL HOMES**

CORAL HOMES PTY LTD. THE COPYRIGHT IN THIS SET OF DRAWINGS IS OWNED BY OR LICENSED TO CORAL HOMES PTY LTD AND MAY NOT BE REPRODUCED, COPIED OR DEALT WITH IN ANY MANNER WHICH INFRINGES THE EXCLUSIVE RIGHTS OF CORAL HOMES PTY LTD AS PRESCRIBED BY THE COPYRIGHT ACT 1968, WITHOUT THE EXPRESS WRITTEN AUTHORISATION OF CORAL HOMES PTY LTD.

QBCC 50792/1014053 OFT 62084C  
 © CORALHOMES PTY. LTD. ALL RIGHTS RESERVED.

REV: TENDER  
 DATE: 17/03/2026  
 REF: 45336  
 SCALE: 1 : 50  
 SHEET NUMBER: 12 of 18

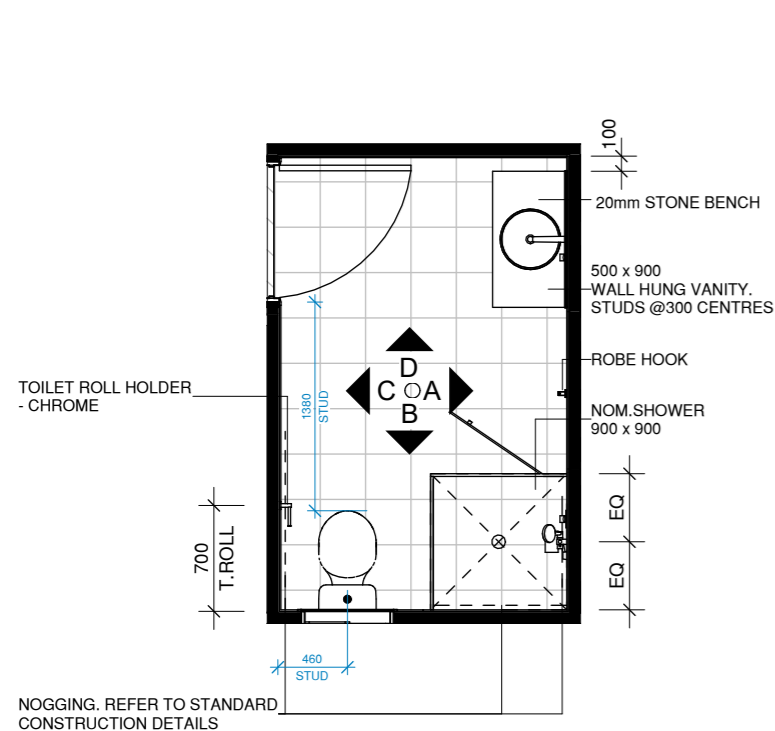

NOGGING. REFER TO STANDARD CONSTRUCTION DETAILS

LOWER - PWD.-LH PLAN

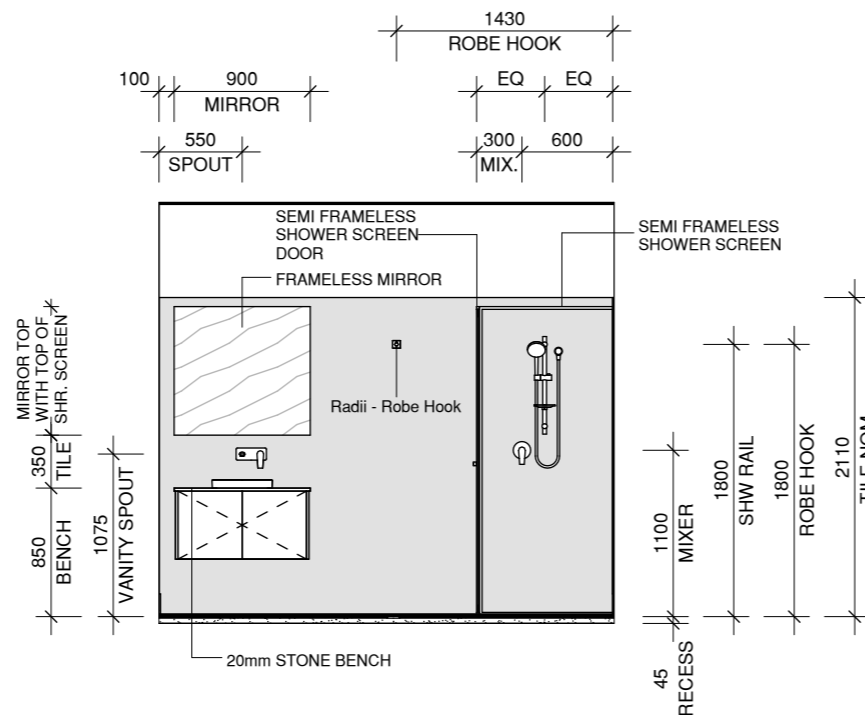

A ELEVATION

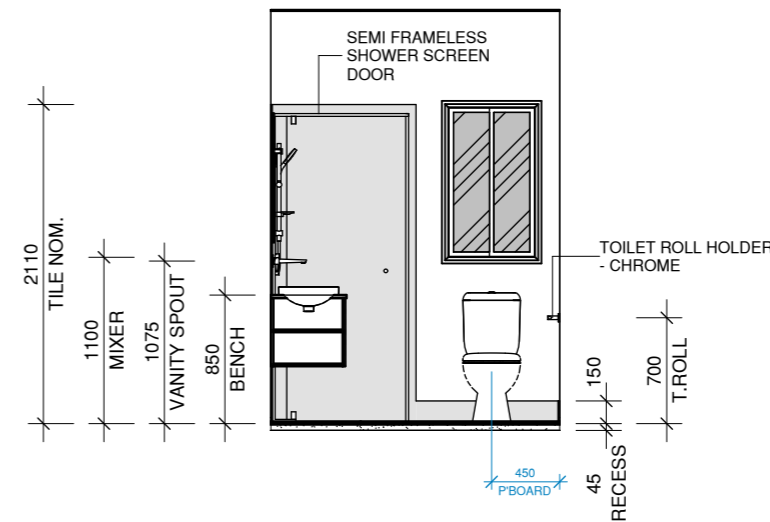

B ELEVATION

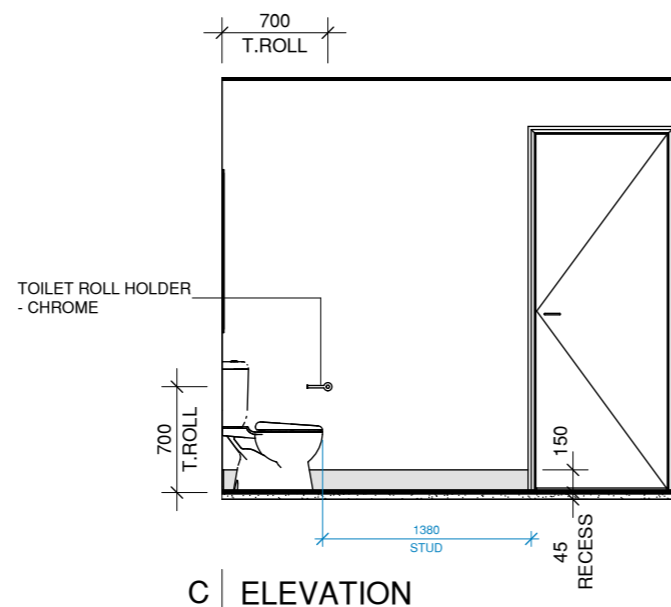

C ELEVATION

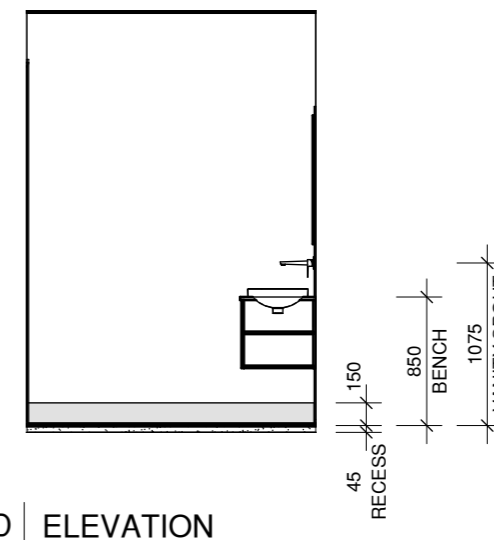

D ELEVATION

BCC DS  
 RECEIVED  
 09/04/2026  
 APPLICATION REF  
 A007000662

CLIENT  
 HN YONG FAMILY HOLDINGS PTY LTD ATF HN  
 YONGFAMILY HOLDINGS TRUST & HNY  
 COPORATION UNITY PTY LTD ATF HNY  
 CORPORATION UNITY TRUST

ADDRESS

LOT 4 (NO.13) CLARENCE STREET  
 CALAMVALE QLD 4116

DESIGN ASHMONT 259Q

FACADE DESIGNER

PLAN RLS - WET AREA 04

**IMPORTANT INFORMATION**

REFER TO WORKING DRAWINGS FOR ALL ROOM DIMENSIONS, ROOM LAYOUT AND WINDOW/DOOR SIZE AND POSITION.

ALL INTERNAL ELEVATIONS DIMENSIONS STATED ARE FROM INSIDE OF WALL LINING (BASED ON 10mm THICK WALL LININGS).

ALL DIMENSIONS ON FLOOR PLAN ARE FROM FRAME.

ALL DIMENSIONS ARE APPROX. ONLY AND MAY VARY DEPENDING ON PRODUCT SELECTION. TOWEL RAILS, TOILET ROLL HOLDERS, SHOWER SCREENS, VANITIES, POWER POINTS, TILE PATTERNS, SIZE AND SETOUTS ARE INDICATIVE ONLY AND ARE NOT TO BE USED FOR ANY OTHER PURPOSE.

DISCONNECTOR GULLIES ARE PROVIDED TO FLOORS OF WET AREAS WITH BASINS AND/OR SHOWERS AND LAUNDRIES WHEN REQUIRED TO ACT AS A FIXTURE TRAP. NO DISCONNECTOR GULLIES ARE PROVIDED TO AREAS WITH KITCHEN SINKS. THESE ARE TO BE POSITIONED ACCORDING TO AS3500 AND TO BE KEPT CLEAR OF ALL STEPS & HOBS.

**MATERIAL LEGEND**

SELECTED TILES

**PRELIMINARY TENDER PLAN**

THESE PLANS ARE PRELIMINARY ONLY AND DO NOT FORM PART OF THE CONTRACT

**CORAL HOMES**

CORAL HOMES PTY LTD. THE COPYRIGHT IN THIS SET OF DRAWINGS IS OWNED BY OR LICENSED TO CORAL HOMES PTY LTD AND MAY NOT BE REPRODUCED, COPIED OR DEALT WITH IN ANY MANNER WHICH INFRINGES THE EXCLUSIVE RIGHTS OF CORAL HOMES PTY LTD AS PRESCRIBED BY THE COPYRIGHT ACT 1968. WITHOUT THE EXPRESS WRITTEN AUTHORISATION OF CORAL HOMES PTY LTD.

QBCC 50792/1014053 OFT 62084C  
 © CORALHOMES PTY. LTD. ALL RIGHTS RESERVED.

REV: TENDER  
 DATE: 17/03/2026  
 REF: 45336  
 SCALE: 1 : 50  
 SHEET NUMBER: 13 of 18

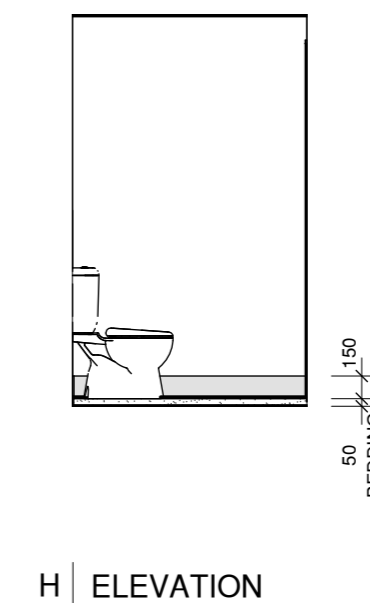
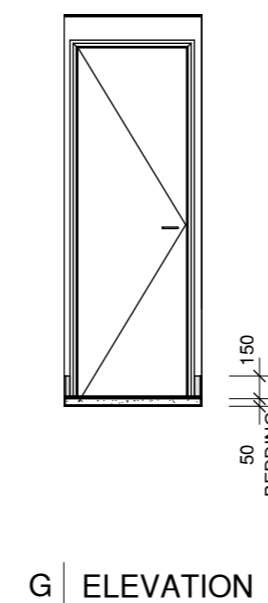
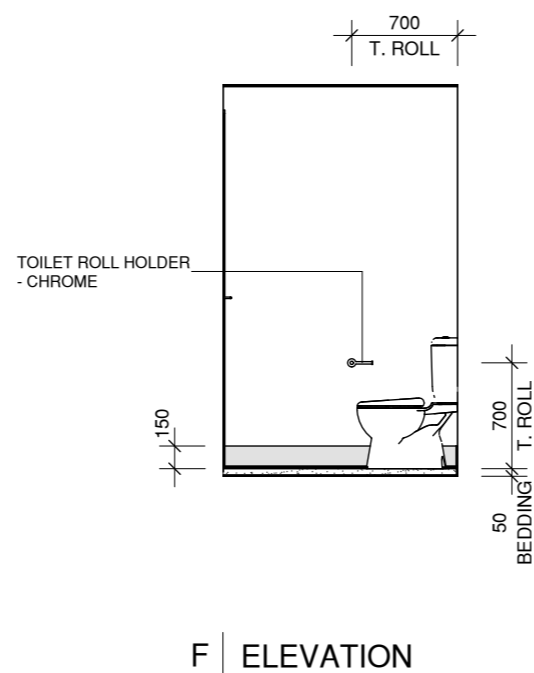
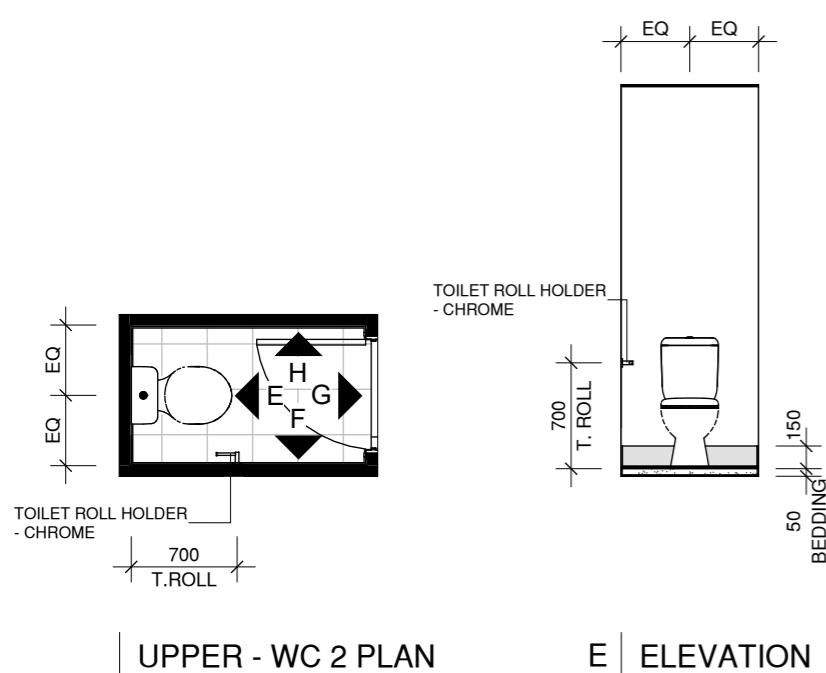
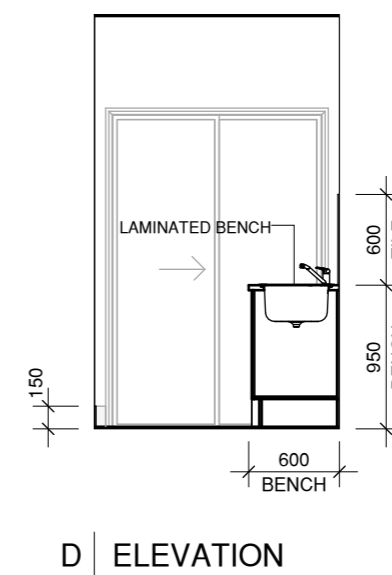
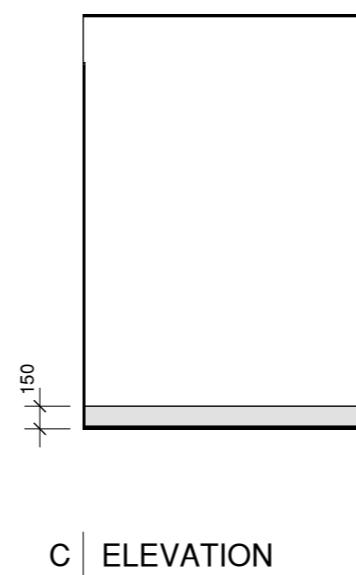
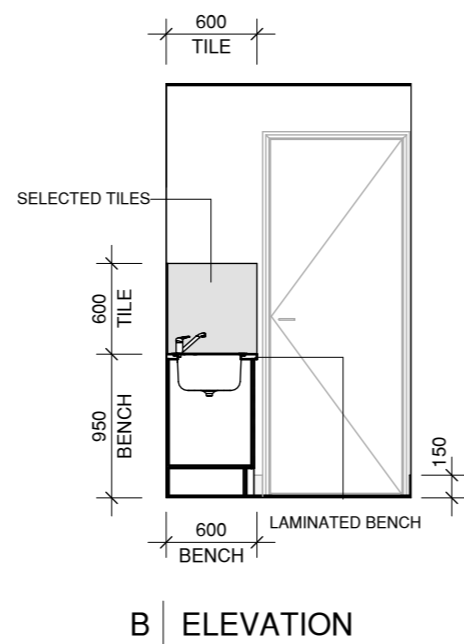
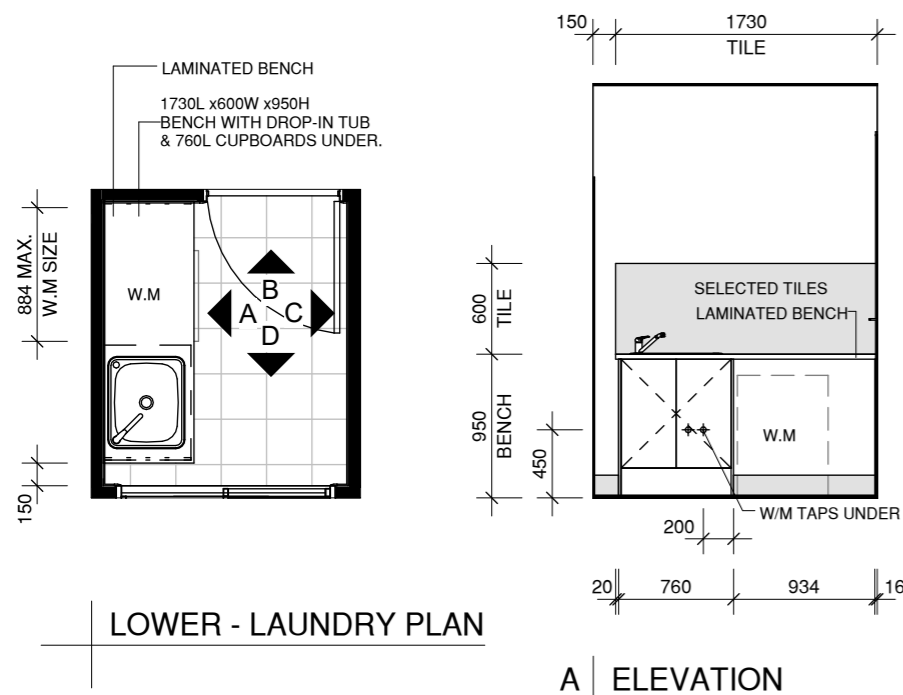

BCC DS  
 RECEIVED  
 09/04/2026  
 APPLICATION REF  
 A007000662

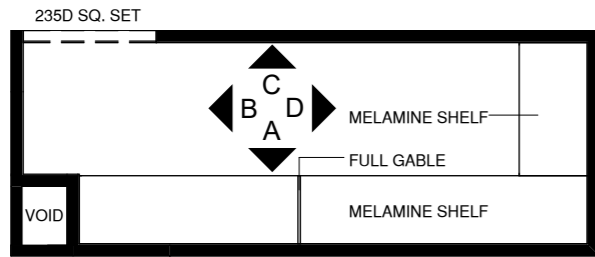

UPPER - WIR 1 PLAN

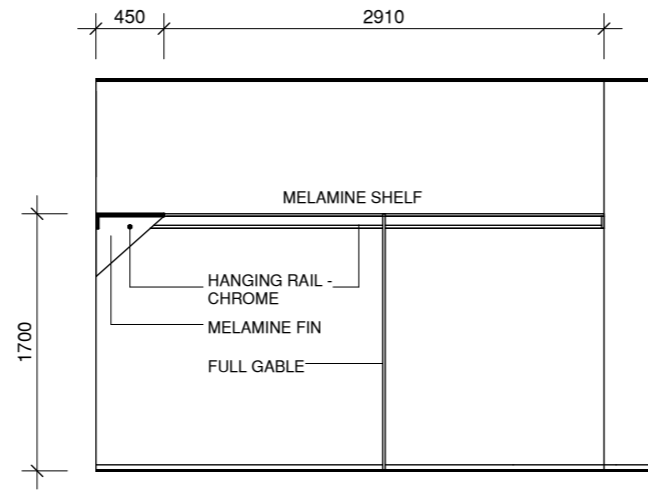

A ELEVATION

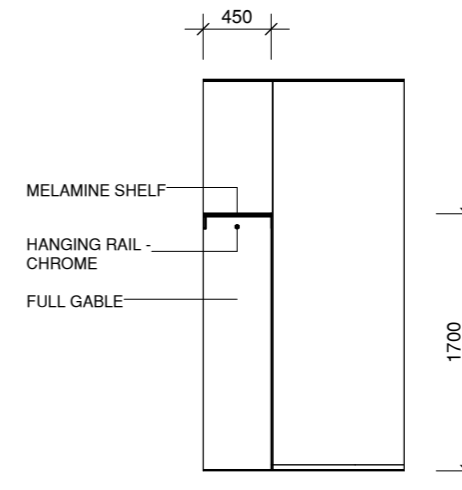

B ELEVATION

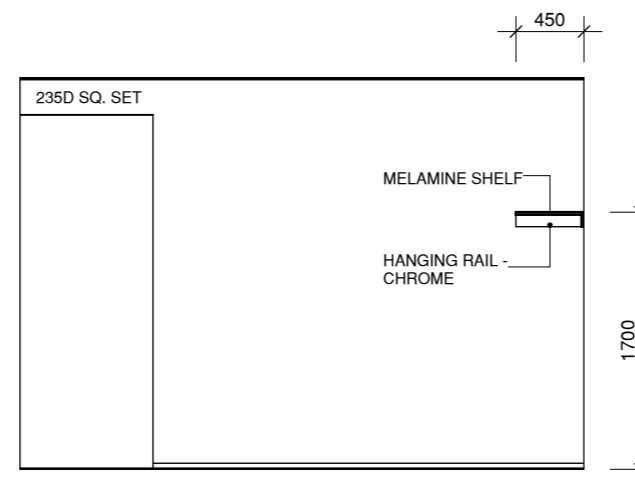

C ELEVATION

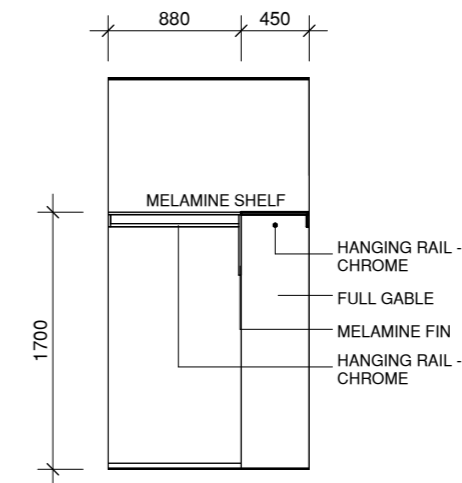

D ELEVATION

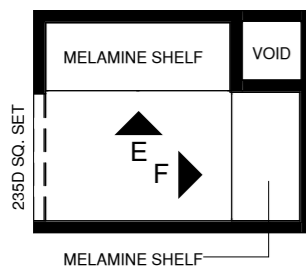

UPPER - WIR 2 PLAN

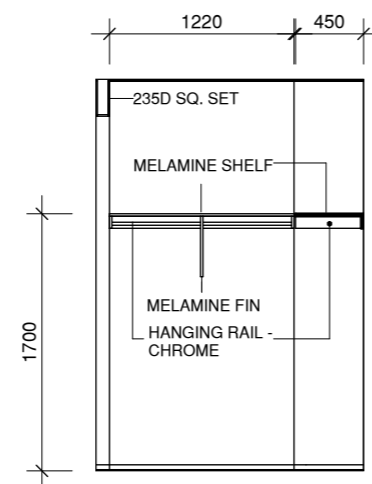

E ELEVATION

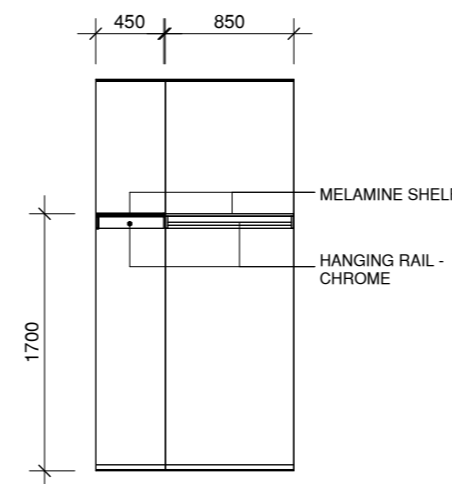

F ELEVATION

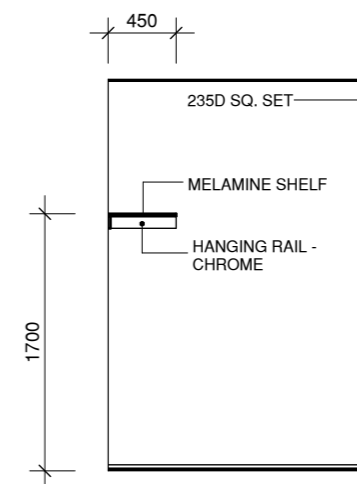

S1 SECTION

CLIENT  
HN YONG FAMILY HOLDINGS PTY LTD ATF HN  
YONGFAMILY HOLDINGS TRUST & HNY  
CORPORATION UNITY PTY LTD ATF HNY  
CORPORATION UNITY TRUST

ADDRESS

LOT 4 (NO.13) CLARENCE STREET  
CALAMVALE QLD 4116

DESIGN ASHMONT 259Q

FACADE DESIGNER

PLAN RLS - WIRS

**IMPORTANT INFORMATION**

REFER TO WORKING DRAWINGS FOR ALL ROOM DIMENSIONS, ROOM LAYOUT AND WINDOW/DOOR SIZE AND POSITION.

ALL INTERNAL ELEVATIONS DIMENSIONS STATED ARE FROM INSIDE OF WALL LINING (BASED ON 10mm THICK WALL LININGS).

ALL DIMENSIONS ON FLOOR PLAN ARE FROM FRAME.

ALL DIMENSIONS ARE APPROX. ONLY AND MAY VARY DEPENDING ON PRODUCT SELECTION.

**PRELIMINARY TENDER PLAN**

THESE PLANS ARE PRELIMINARY ONLY AND DO NOT FORM PART OF THE CONTRACT

**CORAL HOMES**

CORAL HOMES PTY LTD. THE COPYRIGHT IN THIS SET OF DRAWINGS IS OWNED BY OR LICENSED TO CORAL HOMES PTY LTD AND MAY NOT BE REPRODUCED, COPIED OR DEALT WITH IN ANY MANNER WHICH INFRINGES THE EXCLUSIVE RIGHTS OF CORAL HOMES PTY LTD AS PRESCRIBED BY THE COPYRIGHT ACT 1968, WITHOUT THE EXPRESS WRITTEN AUTHORISATION OF CORAL HOMES PTY LTD.

QBCC 50792/1014053 OFT 62084C  
© CORALHOMES PTY. LTD. ALL RIGHTS RESERVED.

REV: TENDER

DATE: 17/03/2026

REF: 45336

SCALE: 1 : 50

SHEET NUMBER: 14 of 18

BCC DS  
RECEIVED  
09/04/2026  
APPLICATION REF  
A007000662

CLIENT  
 HN YONG FAMILY HOLDINGS PTY LTD ATF HN  
 YONGFAMILY HOLDINGS TRUST & HNY  
 COPORATION UNITY PTY LTD ATF HNY  
 CORPORATION UNITY TRUST

ADDRESS

LOT 4 (NO.13) CLARENCE STREET  
 CALAMVALE QLD 4116

DESIGN ASHMONT 259Q

FACADE DESIGNER

PLAN RLS - LINENS & ROBES

**IMPORTANT INFORMATION**

REFER TO WORKING DRAWINGS FOR ALL ROOM DIMENSIONS, ROOM LAYOUT AND WINDOW/DOOR SIZE AND POSITION.

ALL INTERNAL ELEVATIONS DIMENSIONS STATED ARE FROM INSIDE OF WALL LINING (BASED ON 10mm THICK WALL LININGS).

ALL DIMENSIONS ON FLOOR PLAN ARE FROM FRAME.

ALL DIMENSIONS ARE APPROX. ONLY AND MAY VARY DEPENDING ON PRODUCT SELECTION.

**PRELIMINARY TENDER PLAN**

THESE PLANS ARE PRELIMINARY ONLY AND DO NOT FORM PART OF THE CONTRACT

**CORAL HOMES**

CORAL HOMES PTY LTD. THE COPYRIGHT IN THIS SET OF DRAWINGS IS OWNED BY OR LICENSED TO CORAL HOMES PTY LTD AND MAY NOT BE REPRODUCED, COPIED OR DEALT WITH IN ANY MANNER WHICH INFRINGES THE EXCLUSIVE RIGHTS OF CORAL HOMES PTY LTD AS PRESCRIBED BY THE COPYRIGHT ACT 1968, WITHOUT THE EXPRESS WRITTEN AUTHORISATION OF CORAL HOMES PTY LTD.

QBCC 50792/1014053 OFT 62084C  
 © CORALHOMES PTY. LTD. ALL RIGHTS RESERVED.

REV: TENDER  
 DATE: 17/03/2026  
 REF: 45336  
 SCALE: 1 : 50  
 SHEET NUMBER: 15 of 18

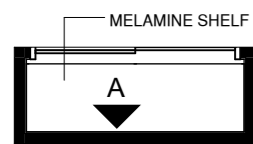

UPPER - ROBE 3 PLAN

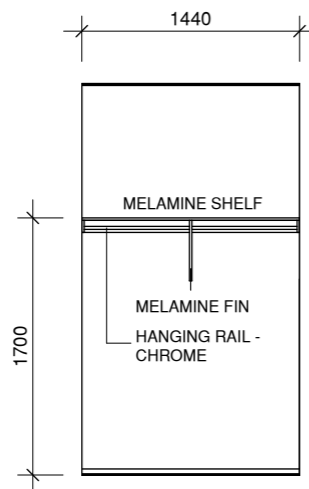

A ELEVATION

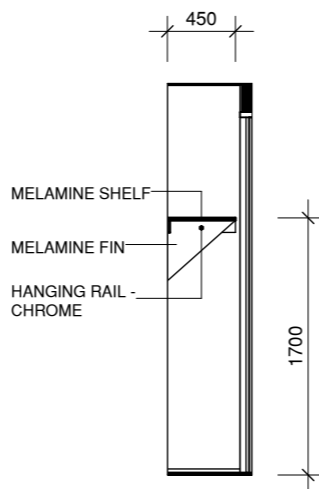

S1 SECTION

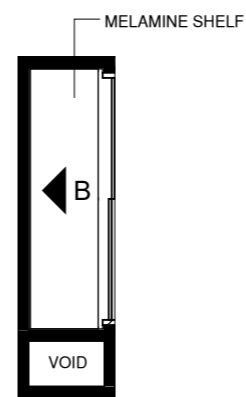

UPPER - ROBE 4 PLAN

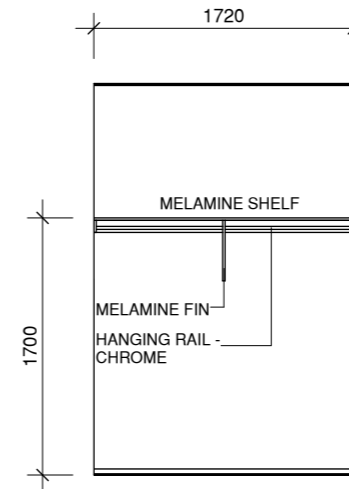

B ELEVATION

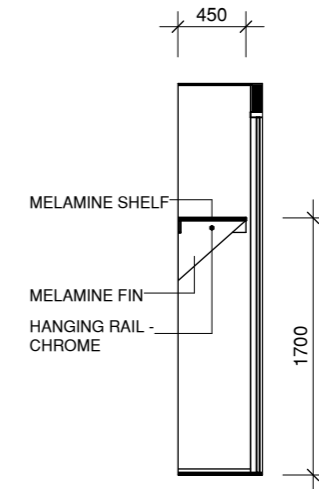

S2 SECTION

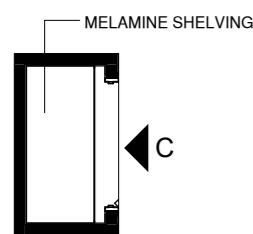

LOWER - LINEN 1 PLAN

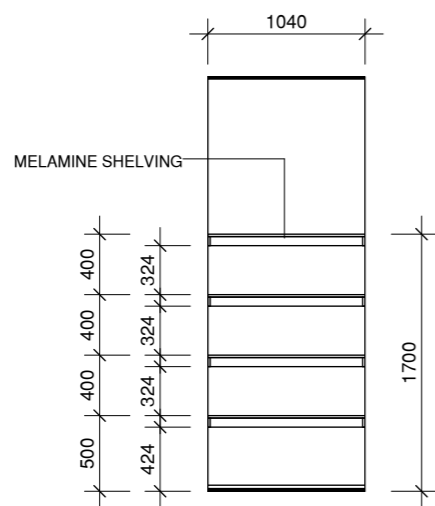

C ELEVATION

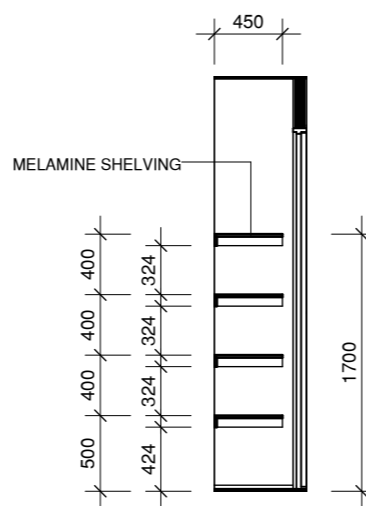

S3 SECTION

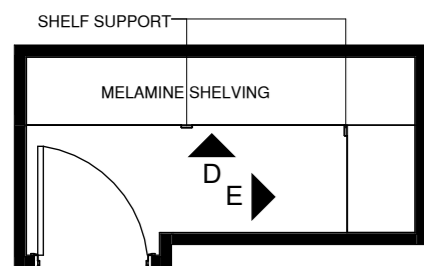

UPPER - LINEN 2 PLAN

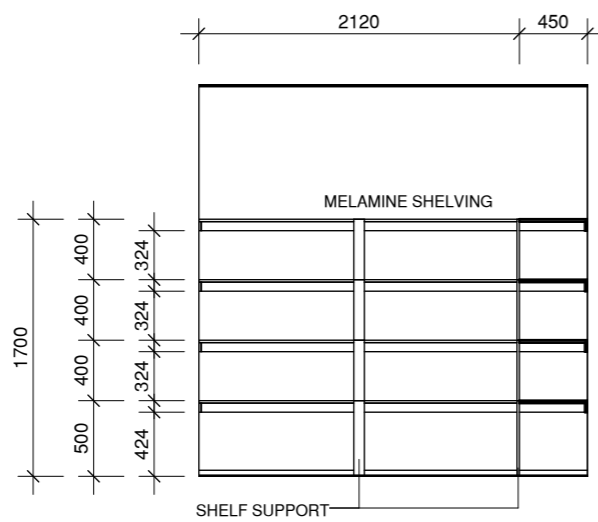

D ELEVATION

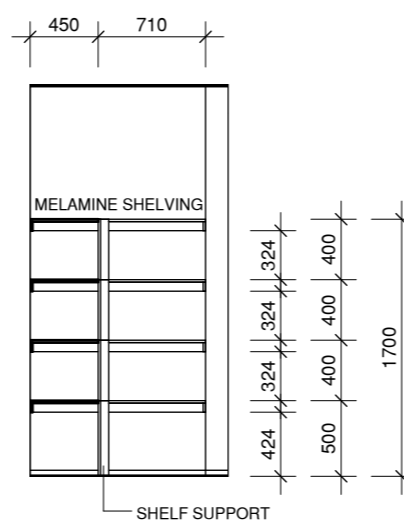

E ELEVATION

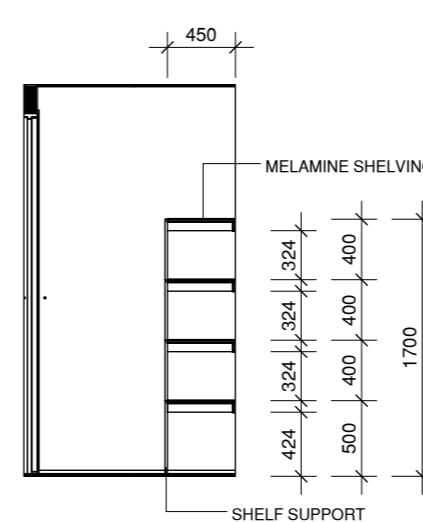

S4 SECTION

BCC DS  
 RECEIVED  
 09/04/2026  
 APPLICATION REF  
 A007000662

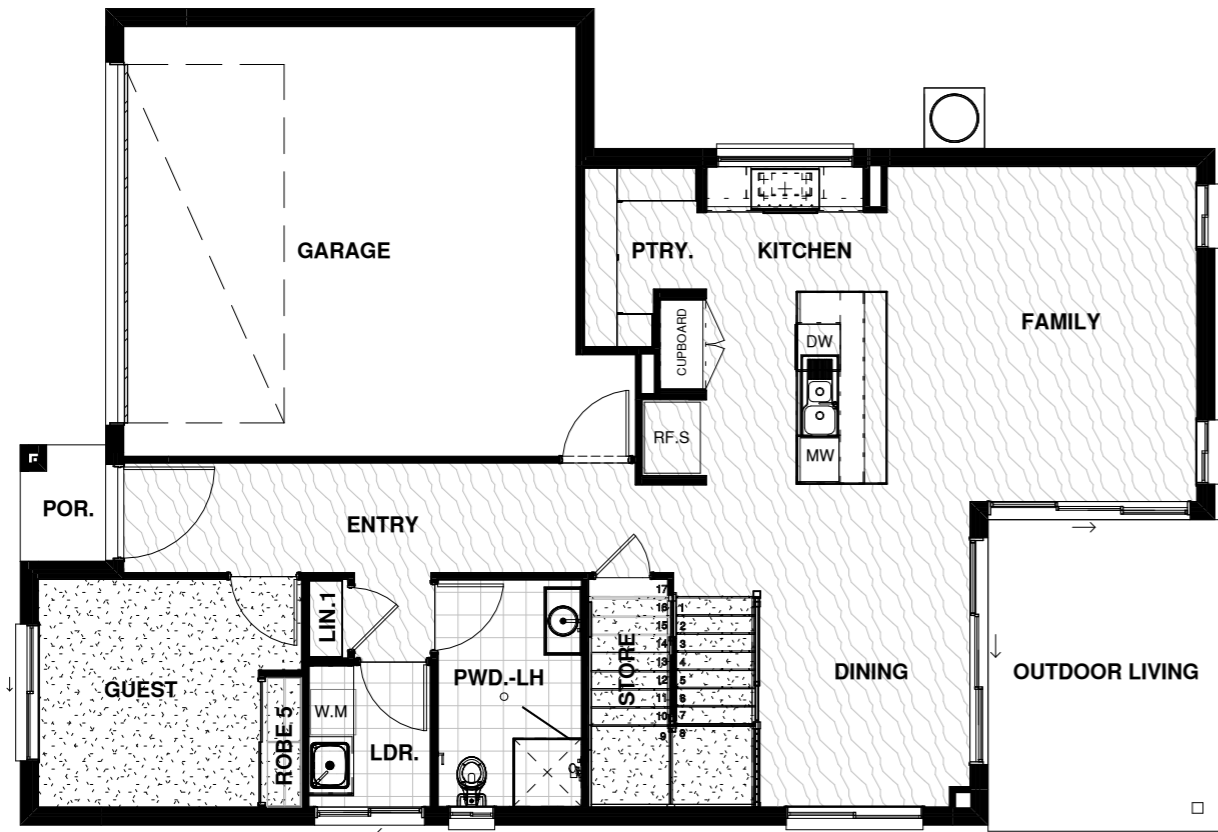

TILES -WALL (m2)	
Locations	Area (m2)
(Tiles) Wet Area Walls	33.823
(Tiles) Kitchen Splashback	1.015

TILES -SKIRTING (m)	
Locations	Length (m)
(Tiles) Wet Area Walls	17.36

TILES -BATH n SHOWER NICHE (m2)	
Locations	Overall Area: (Approx.) (m2)

FLOOR COVERINGS (m2)	
Materials / Locations	Overall Area: (Approx.) (m2)
(Tiles) Wet Area Floors-Lower Floor	8.86
(Tiles) Wet Area Floors-Upper Floor	11.91
CARPET	86.55
CARPET: ROBE	2.57
TIMBER FLOOR	54.90

STAIR CARPET (m2)	
HORIZONTAL AREA	VERTICAL AREA
0.00 m <sup>2</sup>	0.00 m <sup>2</sup>

LOWER LEVEL - FLOOR COVERINGS

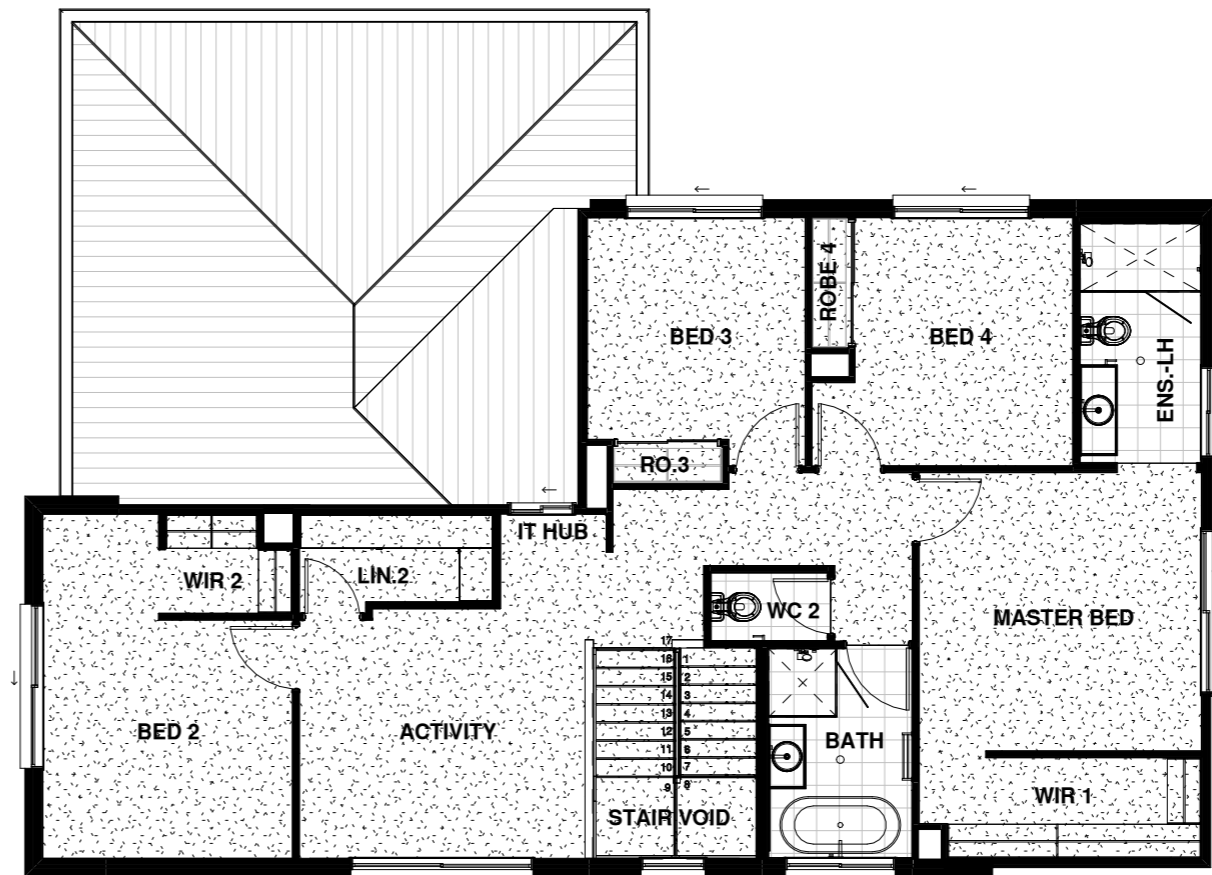

UPPER LEVEL - FLOOR COVERINGS

CLIENT  
 HN YONG FAMILY HOLDINGS PTY LTD ATF HN  
 YONGFAMILY HOLDINGS TRUST & HNY  
 COPORATION UNITY PTY LTD ATF HNY  
 CORPORATION UNITY TRUST

ADDRESS







LOT 4 (NO.13) CLARENCE STREET  
 CALAMVALE QLD 4116

DESIGN ASHMONT 259Q

FACADE DESIGNER

PLAN FLOOR COVERING PLAN

**MATERIAL LEGEND**

-  WET AREA TILE
-  MAIN FLOOR TILE
-  CARPET
-  TIMBER FLOOR
-  HYBRID FLOORING
-  OUTDOOR FLOOR TILE
-  OUTDOOR DECKING

**NOTE:**  
 TILE PATTERNS, SIZE AND SETOUTS  
 ARE INDICATIVE ONLY AND ARE NOT  
 TO BE USED FOR ANY OTHER PURPOSE

**PRELIMINARY  
 TENDER PLAN**

THESE PLANS ARE PRELIMINARY  
 ONLY AND DO NOT FORM  
 PART OF THE CONTRACT

**CORAL  
 HOMES**

CORAL HOMES PTY LTD. THE COPYRIGHT IN THIS SET OF  
 DRAWINGS IS OWNED BY OR LICENSED TO CORAL HOMES PTY  
 LTD AND MAY NOT BE REPRODUCED, COPIED OR DEALT WITH  
 IN ANY MANNER WHICH INFRINGES THE EXCLUSIVE RIGHTS  
 OF CORAL HOMES PTY LTD AS PRESCRIBED BY THE  
 COPYRIGHT ACT 1968, WITHOUT THE EXPRESS WRITTEN  
 AUTHORISATION OF CORAL HOMES PTY LTD.

QBCC 50792/1014053 OFT 62084C  
 © CORALHOMES PTY. LTD. ALL RIGHTS RESERVED.

REV:	TENDER
DATE:	17/03/2026
REF:	45336
SCALE:	1 : 100
SHEET NUMBER:	16 of 18

BCC DS  
 RECEIVED  
 09/04/2026  
 APPLICATION REF  
 A007000662

9.5M MAX. BUILDING HEIGHT

INSULATION TABLE	
ROOF	ANTICON
EXTERNAL WALL	SARKING R2.0 GLASSWOOL BATTS
EXTERNAL CEILING	R3.5 GLASSWOOL BATTS & FAN (OUTDOOR ONLY)
INTERNAL CEILING (UNDER ROOF)	R3.5 GLASSWOOL BATTS
INTERNAL CEILING (SUBFLOOR)	
INTERNAL WALL (GROUND)	
INTERNAL WALL (UPPER)	

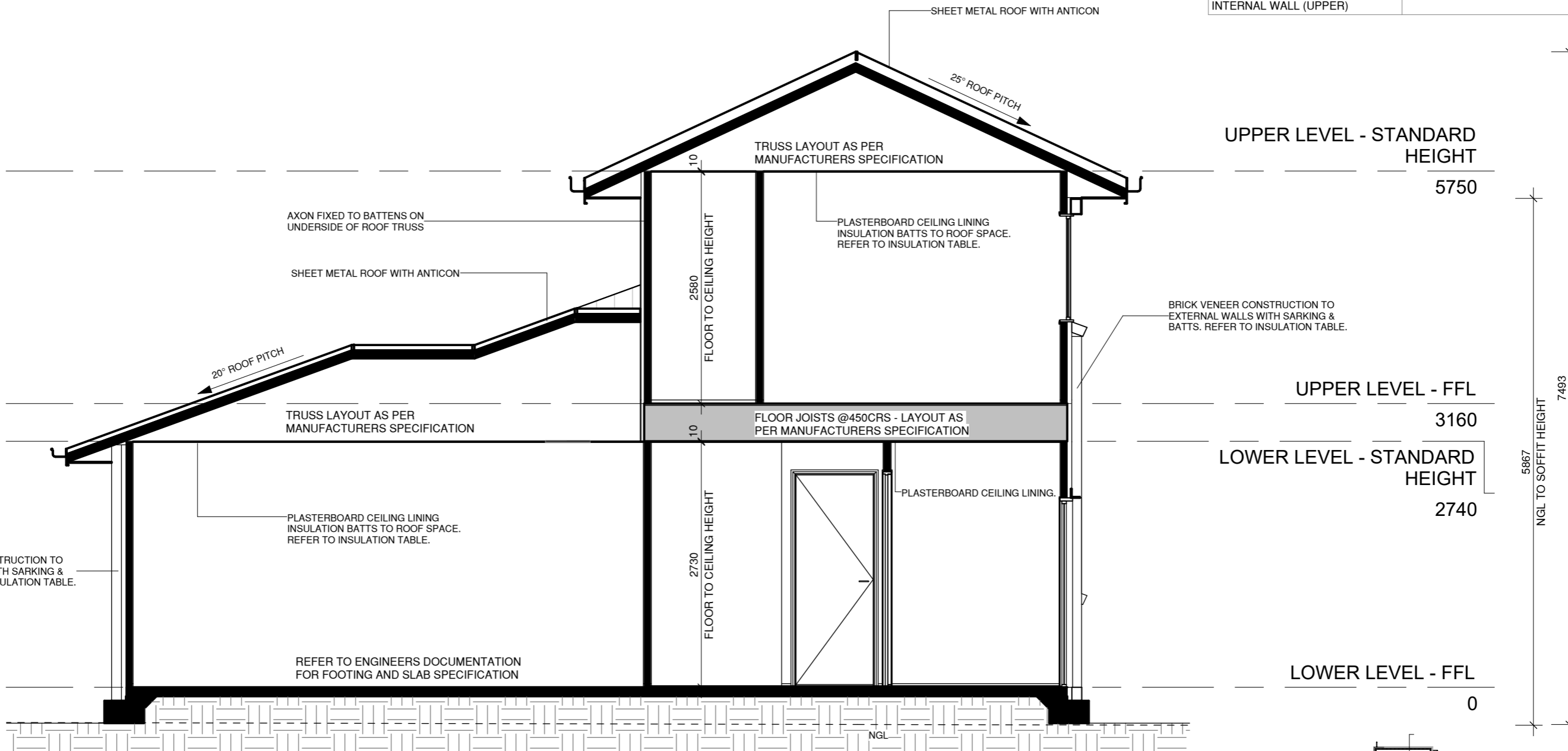

TYPICAL BUILDING SECTION  
1 : 50

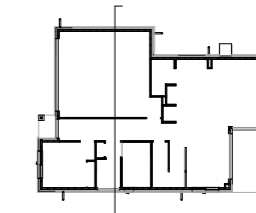

KEY PLAN  
1 : 500

CLIENT HN YONG FAMILY HOLDINGS PTY LTD ATF HN YONGFAMILY HOLDINGS TRUST & HNY CORPORATION UNITY PTY LTD ATF UNITY TRUST	DESIGN ASHMONT 259Q
DESIGNER DESIGNER	FACADE
SECTION	PLAN

BCC DS  
RECEIVED  
09/04/2026  
APPLICATION REF  
A007000662

**PRELIMINARY  
TENDER PLAN**  
THESE PLANS ARE PRELIMINARY  
ONLY AND DO NOT FORM  
PART OF THE CONTRACT

**CORAL HOMES**  
QBCC 50792/1014053 OFT 62084C  
© CORALHOMES PTY. LTD. ALL RIGHTS RESERVED.  
THE COPYRIGHT IN THIS SET OF DRAWINGS IS OWNED BY THE CORAL HOMES GROUP. THESE DRAWINGS MAY NOT BE  
REPRODUCED COPIED / DEALT WITH IN ANY MANNER WHICH INFRINGES THE EXCLUSIVE RIGHTS OF THE CORAL HOMES GROUP  
AS PRESCRIBED BY THE COPYRIGHT ACT 1968, WITHOUT THE EXPRESS WRITTEN AUTHORISATION OF THE CORAL HOMES GROUP

REV:	TENDER
DATE:	17/03/2026
REF:	45336
SCALE:	As indicated
SHEET NUMBER:	17 of 18

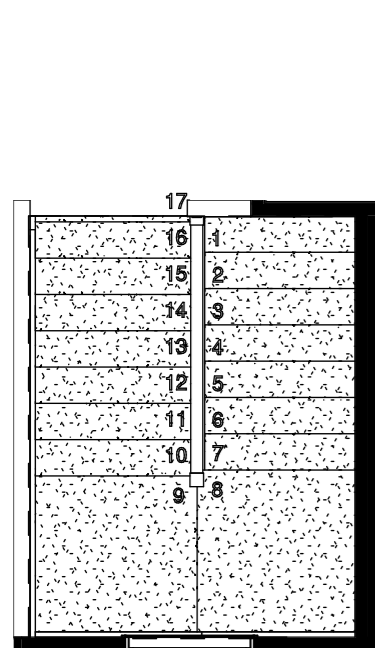

STAIR PLAN

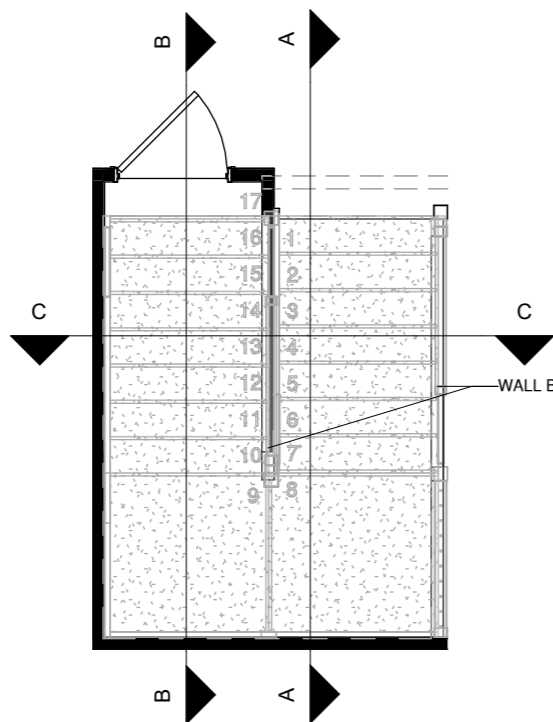

1 : 50



STAIR PLAN B

1 : 50

STAIR MATERIAL

-  CARPET
-  STAINED WOOD FINISH
-  PAINTED FINISH

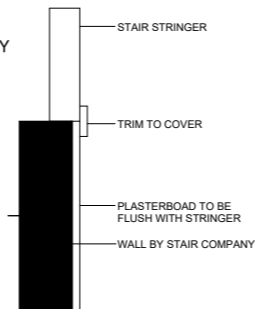

WALL AND STRINGER SECTION

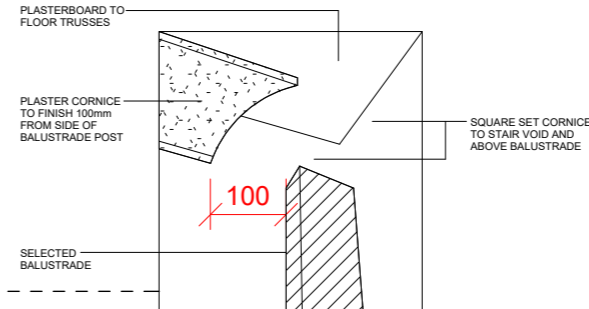

CORNICE DETAIL

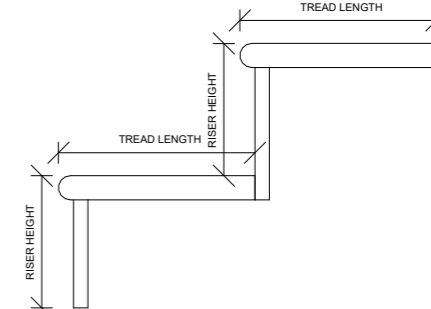

STAIR NOSING PROFILE DETAIL

STAIR TYPE SCHEDULE		
Family	STAIR TYPE	BALUSTRADE TYPE
STAIRS_U SHAPE	STANDARD	DWARF WALL

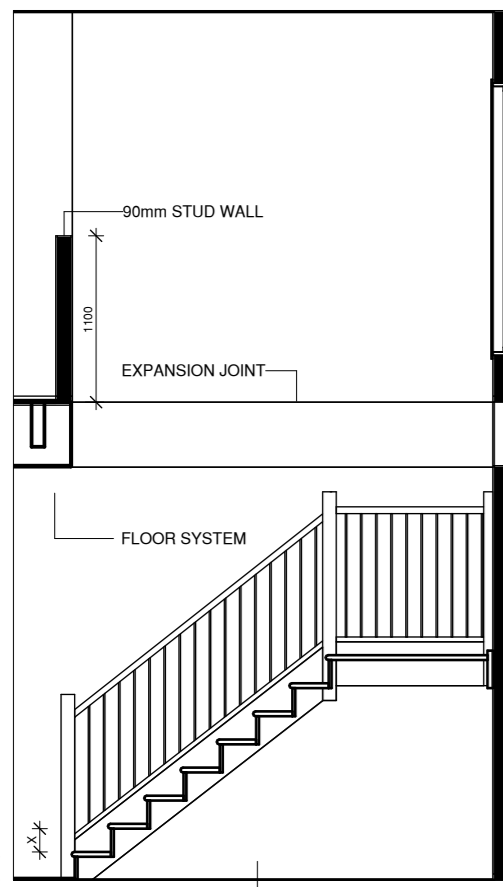

STAIR SECTION A

1 : 50

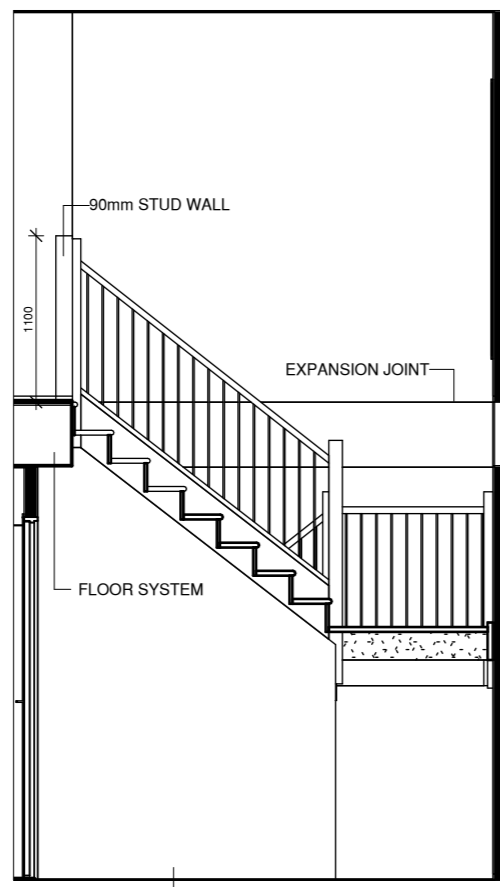

STAIR SECTION B

1 : 50

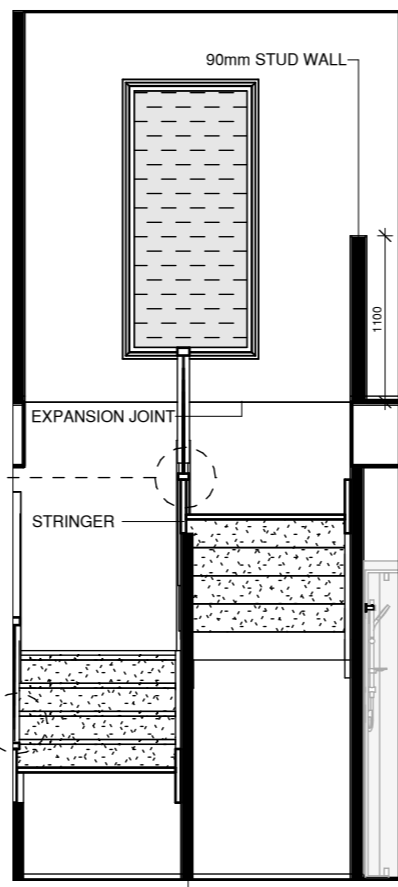

STAIR SECTION C

1 : 50

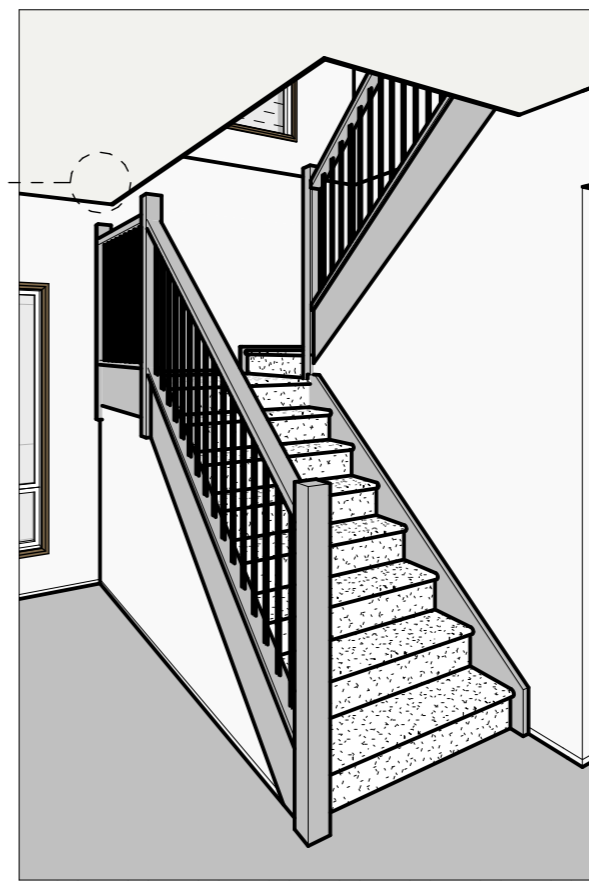

STAIR PERSPECTIVE A

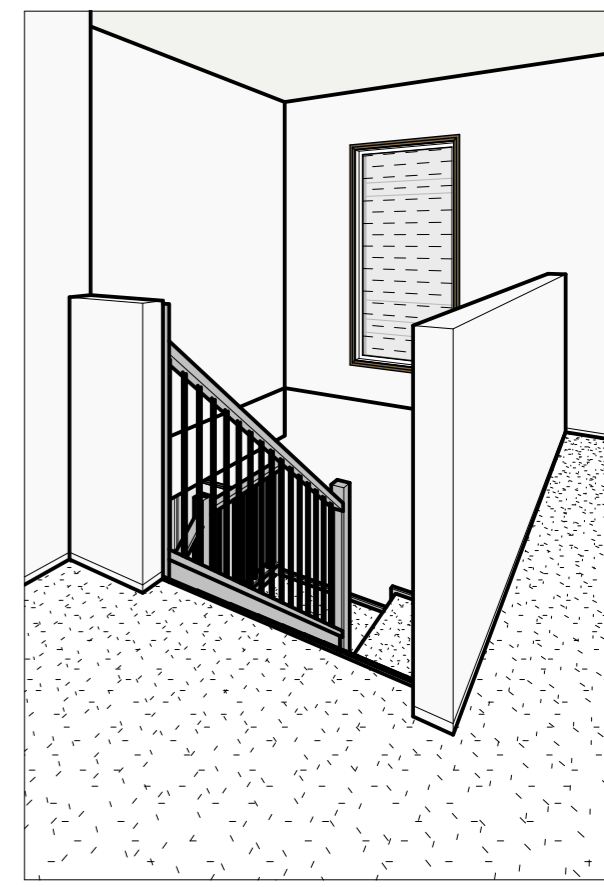

STAIR PERSPECTIVE B

CLIENT  
HN YONG FAMILY HOLDINGS PTY LTD  
ATF HN YONG FAMILY HOLDINGS TRUST &  
HNY CORPORATION UNITY PTY LTD ATF  
UNITY TRUST

**BCC DS**  
**RECEIVED**  
09/04/2026  
**APPLICATION REF**  
A007000662

DESIGN ASHMONT 259Q

FACADE DESIGNER

PLAN STAIR LAYOUT

THE IMAGES SHOWN ARE FOR ILLUSTRATION PURPOSES ONLY AND MAY NOT BE AN EXACT REPRESENTATION OF THE FINISHED PRODUCT. MINOR MANUFACTURING DIFFERENCES IN STAIRS AND BALUSTRADE CONSTRUCTION MAY OCCUR INCLUDING BUT NOT LIMITED TO STAIR TREADS, LANDINGS, BALUSTERS, POSTS AND STRINGERS INCLUDING FINISHES, DETAILS AND DIMENSION, DEPENDENT UPON STAIR AND BALUSTRADE MANUFACTURER.

**PRELIMINARY TENDER PLAN**

THESE PLANS ARE PRELIMINARY ONLY AND DO NOT FORM PART OF THE CONTRACT

**CORAL HOMES**

CORAL HOMES PTY LTD. THE COPYRIGHT IN THIS SET OF DRAWINGS IS OWNED BY OR LICENSED TO CORAL HOMES PTY LTD AND MAY NOT BE REPRODUCED, COPIED OR DEALT WITH IN ANY MANNER WHICH INFRINGES THE EXCLUSIVE RIGHTS OF CORAL HOMES PTY LTD AS PRESCRIBED BY THE COPYRIGHT ACT 1968, WITHOUT THE EXPRESS WRITTEN AUTHORIZATION OF CORAL HOMES PTY LTD.

QBCC 50792/1014053 OFT 62084C  
© CORAL HOMES PTY. LTD. ALL RIGHTS RESERVED.

REV: TENDER

DATE: 17/03/2026

REF: 45336

SCALE: 1 : 50

SHEET NUMBER: 18 of 18

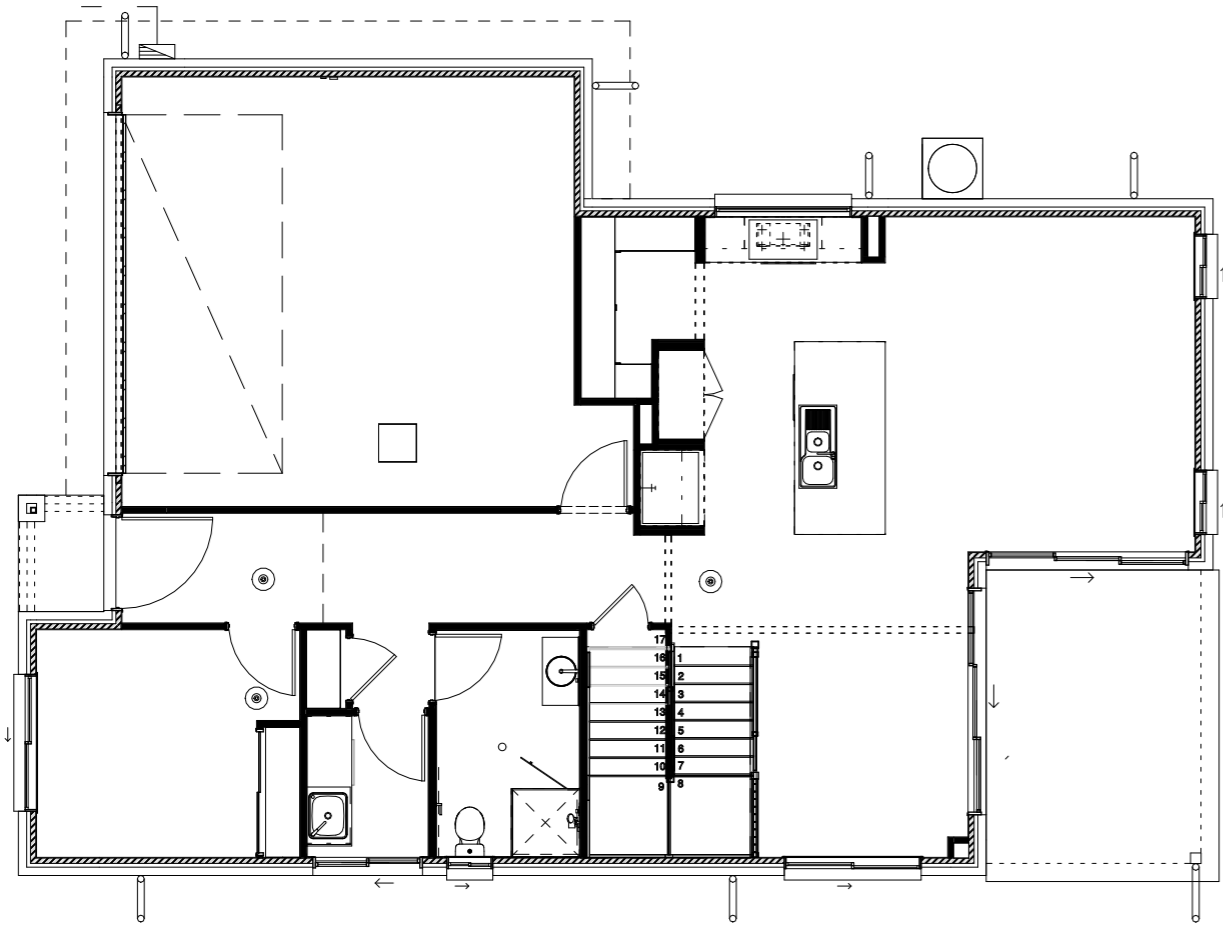

LOWER LEVEL - ELECTRICAL

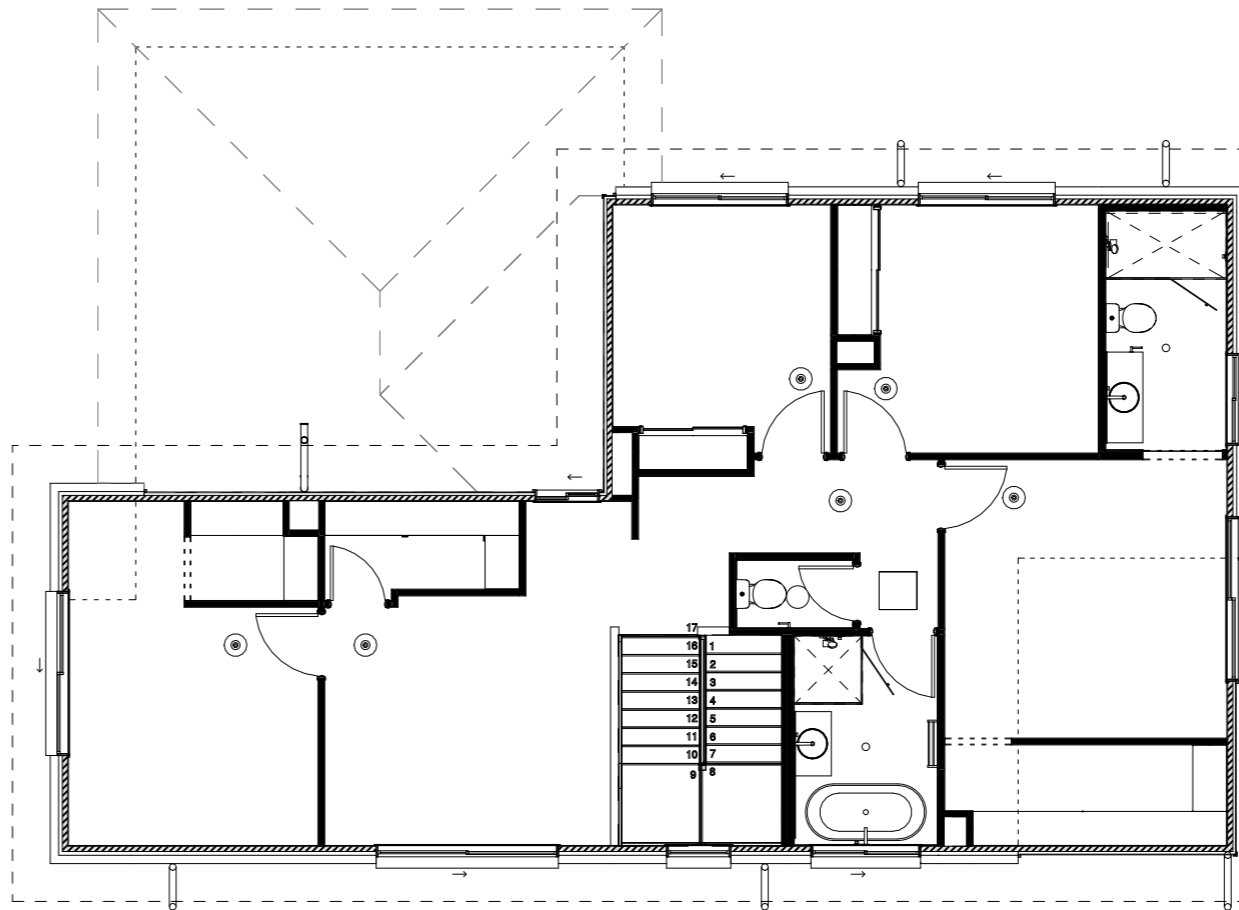

UPPER LEVEL - ELECTRICAL

CLIENT  
 HN YONG FAMILY HOLDINGS PTY LTD ATF HN  
 YONGFAMILY HOLDINGS TRUST & HNY  
 COPORATION UNITY PTY LTD ATF HNY  
 CORPORATION UNITY TRUST

ADDRESS

LOT 4 (NO.13) CLARENCE STREET  
 CALAMVALE QLD 4116

DESIGN ASHMONT 259Q

FACADE DESIGNER

PLAN ELECTRICAL PLAN

**PRELIMINARY  
 TENDER PLAN**

THESE PLANS ARE PRELIMINARY  
 ONLY AND DO NOT FORM  
 PART OF THE CONTRACT

**CORAL  
 HOMES**

CORAL HOMES PTY LTD. THE COPYRIGHT IN THIS SET OF  
 DRAWINGS IS OWNED BY OR LICENSED TO CORAL HOMES PTY  
 LTD AND MAY NOT BE REPRODUCED, COPIED OR DEALT WITH  
 IN ANY MANNER WHICH INFRINGES THE EXCLUSIVE RIGHTS  
 OF CORAL HOMES PTY LTD AS PRESCRIBED BY THE  
 COPYRIGHT ACT 1968, WITHOUT THE EXPRESS WRITTEN  
 AUTHORISATION OF CORAL HOMES PTY LTD.

QBCC 50792/1014053 OFT 62084C  
 © CORALHOMES PTY. LTD. ALL RIGHTS RESERVED.

REV:	TENDER
DATE:	17/03/2026
REF:	45336
SCALE:	1 : 100
SHEET NUMBER:	01 of 01

BCC DS  
 RECEIVED  
 09/04/2026  
 APPLICATION REF  
 A007000662