

6 May 2026

LFL Projects
240 Queen Street
Brisbane QLD 4000

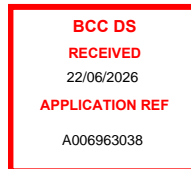

Attention: Lachlan Marks

Dear Lachlan,

**RE: 36 WARRY STREET, FORTITUDE VALLEY
RESPONSE TO COUNCIL INFORMATION REQUEST**

Previously submitted swept paths of a Brisbane City Council (BCC) rear-lift refuse collection vehicle (RCV) have been revised, as requested in Item 10b in BCC's Information Request dated 27 March 2026 (Development Reference: A006963038). The revised RCV swept path is attached and adopts a 9.757 kerb-to-kerb and six second lock-to-lock minimum turning radius, in accordance with BCC Standard Drawing BSD-3008-2. As demonstrated, the proposed access driveway width (ie 6.35m) adequately caters for RCV access/egress and as such, no additional changes to the proposed access design are considered necessary.

If you have any questions regarding the issues discussed above, please do not hesitate to contact us.

Yours sincerely,

A handwritten signature in black ink that reads "C. Glover".

Casey Glover
Principal Engineer (RPEQ 34450)

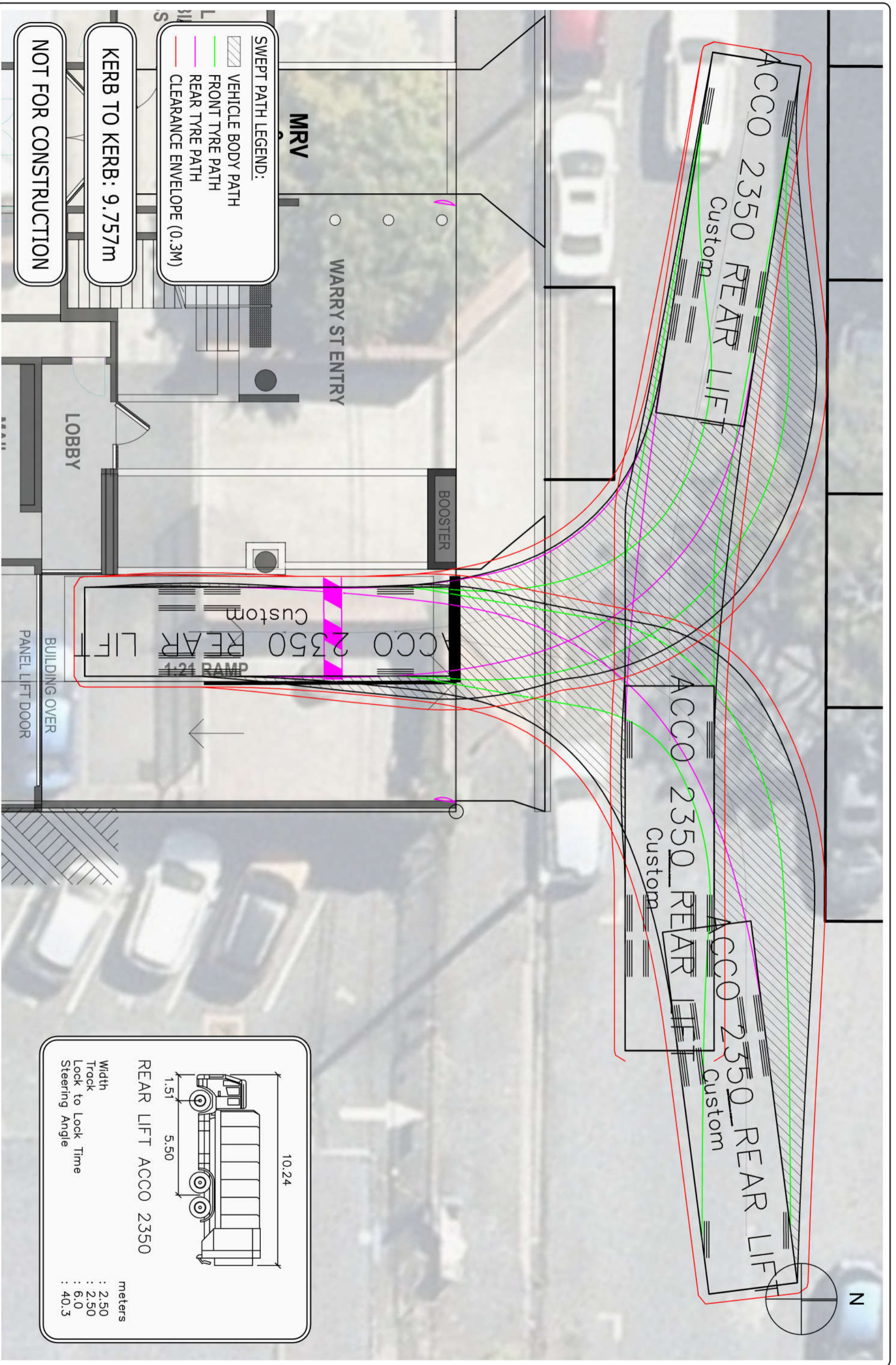

SWEPT PATH LEGEND:

- VEHICLE BODY PATH
- FRONT TYRE PATH
- REAR TYRE PATH
- CLEARANCE ENVELOPE (0.3M)

KERB TO KERB: 9.757m

NOT FOR CONSTRUCTION

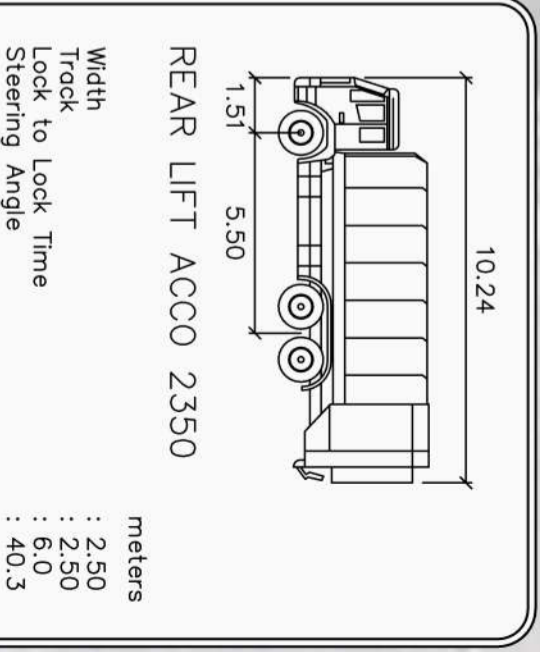

FTT
TRAFFIC & TRANSPORT ENGINEERING

ABN 96 067 593 962
P 07 3839 6771 WWW.PTT.COM.AU
Level 2, 62 Astor Ter, Spring Hill QLD 4000

REV	DESCRIPTION	CG	DATE
B	IR RESPONSE - UPDATED TURNING RADIUS	CG	06/05/26
A	INITIAL ISSUE	CG	12/12/25

DRAWING TITLE: RCV SERVICING

PROJECT TITLE: 36 WARRY ST, FORTITUDE VALLEY

DRAWING NO: 26-076-001	REV: B	SCALE: 1:100 @ A3
CLIENT: LFL PROJECTS	APPROVED BY: CG (RPEQ 34450)	

C. Spence

P:\2025-2026-078 37 Fortitude Valley\CA\1518-001A